

1990-1994
SUZUKI

Samurai

SUPPLEMENTARY SERVICE MANUAL

USE THIS MANUAL WITH:
SAMURAI SERVICE MANUAL (99500-83310)

SUZUKI
Caring for Customers

99501-83350-33E
(英)

IMPORTANT

WARNING/CAUTION/NOTE

Please read this manual and follow its instructions carefully. To emphasize special information, the words **WARNING**, **CAUTION**, and **NOTE** have, special meanings. Pay special attention to the messages highlighted by these signal words.

WARNING:

Indicates a potential hazard that could result in death or injury.

CAUTION:

Indicates a potential hazard that could result in vehicle damage.

NOTE:

Indicates special information to make maintenance easier or instructions clearer.

FOREWORD

This SUPPLEMENTARY SERVICE MANUAL is a supplement to "SAMURAI 1988 MODEL SERVICE MANUAL".

Applicable model:

1990, 1991, 1992, 1993 and 1994 SAMURAI 4WD MODEL.

1991, 1992, 1993 and 1994 SAMURAI 2WD MODEL.

It describes single point Electronic Fuel Injection system and different service information of SAMURAI 1990, 1991, 1992, 1993 and 1994 MODEL as compared with SAMURAI 1988 MODEL.

Therefore, whenever servicing SAMURAI 1990, 1991, 1992, 1993 or 1994 MODEL, consult GROUP 1, 2 and/or 3 in this supplement first. And for any section, item or description not found in this supplement, refer to "SAMURAI 1988 MODEL SERVICE MANUAL".

All information, illustrations and specifications contained in this literature are based on the latest product information available at the time of publication approval. And used as the main subject of description is the vehicle of standard specifications among others. Therefore, note that illustrations may differ from the vehicle being actually serviced. The right is reserved to make changes at any time without notice.

RELATED SERVICE MANUAL:
1988 SAMURAI SERVICE MANUAL
(99500-83310-33E)

SUZUKI MOTOR CORPORATION

AUTOMOBILE DEPARTMENT
OVERSEAS SERVICE DIVISION

© COPYRIGHT SUZUKI MOTOR CORPORATION 1993

TABLE OF CONTENTS

	SECTION
GENERAL, SPECIAL TOOLS AND SERVICE MATERIALS	0
PERIODIC MAINTENANCE SERVICE	1
TROUBLE SHOOTING	2
ENGINE	3
FUEL SYSTEM (Fuel tank, pump, filter and lines)	4
ELECTRONIC FUEL INJECTION SYSTEM	4A
EMISSION CONTROL SYSTEM	5
IGNITION SYSTEM	8
CHARGING SYSTEM	10
CLUTCH	11
PROPELLER SHAFTS	15
BRAKES	19
BODY ELECTRICAL EQUIPMENT	21
SERVICE DATA	22
SUPPLEMENT FOR 1991-1993 2WD MODELS	GROUP 2
SUPPLEMENT FOR 1994 MODEL	GROUP 3

GENERAL PRECAUTIONS

The WARNING and CAUTION below describe some general precautions that you should observe when servicing a vehicle. These general precautions apply to many of the service procedures described in this manual, and they will not necessarily be repeated with each procedure to which they apply.

WARNING:

- Whenever raising a vehicle for service, be sure to follow the instructions under "STANDARD SHOP PRACTICES" on SECTION O of this manual.
- When it is necessary to do service work with the engine running, make sure that the parking brake is set fully and the transmission is in Neutral (for manual transmission vehicles) or Park (for automatic transmission vehicles). Keep hands, hair, clothing, tools, etc. away from the fan and belts when the engine is running.
- When it is necessary to run the engine indoors, make sure that the exhaust gas is forced outdoors.
- Do not perform service work in areas where combustible materials can come in contact with a hot exhaust system. When working with toxic or flammable materials (such as gasoline and refrigerant), make sure that the area you work in is well-ventilated.
- To avoid getting burned, keep away from hot metal parts such as the radiator, exhaust manifold, tailpipe, muffler, etc.

CAUTION:

- Before starting any service work, cover fenders, seats, and any other parts that are likely to get scratched or stained during servicing. Also, be aware that what you wear (e.g. buttons) may cause damage to the vehicle's finish.
- When removing parts that are to be reused, be sure to keep them arranged in an orderly manner so that they may be reinstalled in the proper order and position.
- When performing service to electrical parts that does not require use of battery power, disconnect the negative cable of the battery.
- When removing the battery, be sure to disconnect the negative cable first and then the positive cable. When reconnecting the battery, connect the positive cable first and then the negative cable, and replace the terminal covers.
- Whenever you use oil seals, gaskets, packing, O-rings, locking washers, split pins, self-locking nuts, circlips and certain other parts as specified, be sure to use new ones. Also, before installing new gaskets, packing, etc., be sure to remove any residual material from the mating surfaces.
- Make sure that all parts used in reassembly are perfectly clean.
- When use of a certain type of lubricant, bond, or sealant is specified, be sure to use the specified type.
- Be sure to use special tools when instructed.
- When disconnecting vacuum hoses, attach a tag describing the correct installation position so that the hoses can be reinstalled correctly.
- After servicing fuel, oil, water, vacuum, exhaust, or brake systems, check all lines related to the system for leaks.
- Be careful not to touch the electrical terminals of parts which use microcomputers (e.g. electronic control unit). The static electricity from your body can damage these parts.
- When taking measurements at electrical connectors using a tester probe, be sure to insert the probe from the wire harness side (backside) of the connector.
- For vehicles equipped with a catalytic converter, be careful not to let a large amount of unburned gasoline enter the converter or it can be damaged. Conduct a spark jump test only when necessary, make it as short as possible, and do not open the throttle. Conduct engine compression checks within the shortest possible time. Avoid situations which can result in engine misfire (e.g. starting the engine when the fuel tank is nearly empty).
- For vehicles equipped with fuel injection systems, never disconnect the fuel line between the fuel pump and injector without first releasing the fuel pressure, or fuel can be sprayed out under pressure.

SECTION 0

GENERAL, SPECIAL TOOLS AND SERVICE MATERIALS

0

CONTENTS

0-1. IDENTIFICATION NUMBER	0-1
0-2. STANDARD SHOP PRACTICES . . .	Refer to '88 model SERVICE MANUAL.
0-3. SPECIAL TOOLS	Refer to '88 model SERVICE MANUAL and each section of this supplement.
0-4. REQUIRED SERVICE MATERIALS	} Refer to '88 model SERVICE MANUAL.
0-5. METRIC INFORMATION	

0-1. IDENTIFICATION NUMBER

VEHICLE IDENTIFICATION NUMBER

The vehicle identification number is on the instrument panel left side. Refer to below figure for detailed VIN cord information and its location.

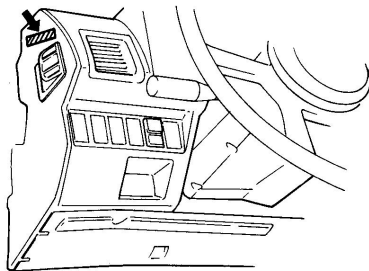
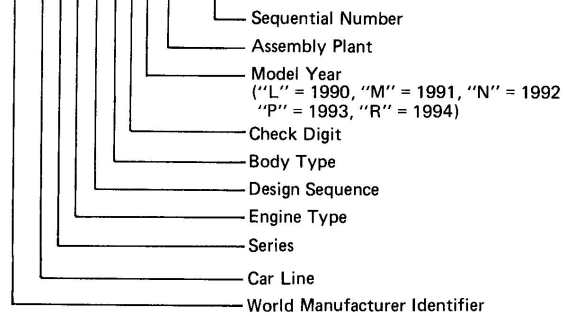

Fig. 0-1

JS4 J C 3 1 C □ N 4 100001



ENGINE IDENTIFICATION NUMBER

The engine number is punched on the rear portion of the left-hand skirt part of cylinder block.

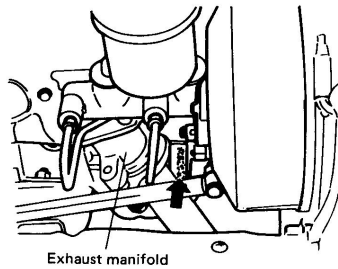

Fig. 0-2 Location of Engine No.

0-1

SECTION 1

PERIODIC MAINTENANCE SERVICE

1

CONTENTS

1-1. MAINTENANCE SCHEDULE	1-2
Maintenance recommended under severe driving conditions	1-4
1-2. ENGINE AND EMISSION CONTROL	1-5
NOTE:	
For the maintenance items (maintenance procedure) not found here, refer to '88 MODEL SERVICE MANUAL.	
2. Camshaft timing belt inspection	1-5
9. Oxygen sensor replacement	1-5
10. Catalytic converter inspection	1-6
11. Charcoal canister replacement	1-6
13. EGR system inspection	1-7
14. ECM and associated sensors inspection	1-7
19. Ignition timing inspection	1-7
22. Fuel filter replacement	1-8
23. Fuel lines and connections inspection	1-8
24. Idle speed inspection	1-8
25. Fuel injector inspection	1-8
1-3. CHASSIS AND BODY	Refer to '88 model SERVICE MANUAL.

1-1. MAINTENANCE SCHEDULE

NOTE:

For Federal Specification Vehicles except Californian and Canadian Specification Vehicles, the "CHECK ENGINE" light in the combination meter lights at the mileage of 50,000, 80,000 and 100,000 miles each of which is detected by the mileage sensor. Upon completion of maintenance service of items (8, 9, 10, 11, 13, 14 & 25) required for each mileage, be sure to turn off the "CHECK ENGINE" light cancel switch, referring to SECTION 4A (p. 4A-16) of this manual. Then the mileage sensor will be reset.

	miles (x 1,000)		37.5		45		52.5		60		67.5		75		82.5		90		97.5		105		112.5		120		
	km (x 1,000)		60		72.5		85		100		112.5		125		137.5		150		162.5		175		187.5		200		
	months		7.5		15		22.5		30		37.5		45		52.5		60		67.5		75		82.5		90		97.5
ENGINE & EMISSION CONTROL																											
1. Fan (Water pump) drive belt	-	-	-	-	-	-	-	-	-	-	-	-	-	-	-	-	-	-	-	-	-	-	-	-	-	-	-
2. Camshaft timing belt	-	-	-	-	-	-	-	-	-	-	-	-	-	-	-	-	-	-	-	-	-	-	-	-	-	-	-
3. Valve lash (clearance)	-	-	-	-	-	-	-	-	-	-	-	-	-	-	-	-	-	-	-	-	-	-	-	-	-	-	-
4. Engine oil and oil filter	R	R	R	R	R	R	R	R	R	R	R	R	R	R	R	R	R	R	R	R	R	R	R	R	R	R	R
5. Cooling system hoses and connections	-	-	-	-	-	-	-	-	-	-	-	-	-	-	-	-	-	-	-	-	-	-	-	-	-	-	-
6. Engine coolant	-	-	-	-	-	-	-	-	-	-	-	-	-	-	-	-	-	-	-	-	-	-	-	-	-	-	-
7. Exhaust pipes and mountings	-	-	-	-	-	-	-	-	-	-	-	-	-	-	-	-	-	-	-	-	-	-	-	-	-	-	-
8. PCV valve	Replace at 50,000 miles (83,000 km) and 100,000 miles (166,000 km)																										
9. Oxygen sensor	Replace at 80,000 miles (133,000 km)																										
10. Catalytic converter	Inspect at 100,000 miles (166,000 km)																										
11. Charcoal canister	Replace at 100,000 miles (166,000 km)																										
12. Emission-related hoses & tubes	-	-	-	-	-	-	-	-	-	-	-	-	-	-	-	-	-	-	-	-	-	-	-	-	-	-	-
*13. EGR system	Inspect at 50,000 miles (83,000 km) and 100,000 miles (166,000 km)																										
14. ECM & associated sensors	Inspect at 100,000 miles (166,000 km)																										
15. Wiring harness and connections	-	-	-	-	-	-	-	-	-	-	-	-	-	-	-	-	-	-	-	-	-	-	-	-	-	-	-
IGNITION SYSTEM																											
16. Spark plugs	-	-	-	-	-	-	-	-	-	-	-	-	-	-	-	-	-	-	-	-	-	-	-	-	-	-	-
17. Distributor cap and rotor	-	-	-	-	-	-	-	-	-	-	-	-	-	-	-	-	-	-	-	-	-	-	-	-	-	-	-
18. Ignition wiring	-	-	-	-	-	-	-	-	-	-	-	-	-	-	-	-	-	-	-	-	-	-	-	-	-	-	-
19. Ignition timing	-	-	-	-	-	-	-	-	-	-	-	-	-	-	-	-	-	-	-	-	-	-	-	-	-	-	-

NOTES:

- Item 5 **, Item 6 **R and Item 7 **I are recommended maintenance items.
- Item 7 (R) is applicable to exhaust mounting rubber only.
- Item *13 EGR system inspection is a recommended maintenance item for Canadian Specification vehicles although it is one of periodical inspection items for any other specification vehicles.

MAINTENANCE RECOMMENDED UNDER SEVERE DRIVING CONDITIONS

If the vehicle is usually used under the conditions corresponding to any severe condition code given below, it is recommended that applicable maintenance operation be performed at the particular interval as given in the below chart.

Severe condition code

- | | |
|---|---|
| A – Towing a trailer | E – Driving in extremely cold weather and/or salted roads |
| B – Repeated short trips | F – Repeated short trips in extremely cold weather |
| C – Driving on rough and/or muddy roads | |
| D – Driving on dusty roads | |

Severe Condition Code	Maintenance	Maintenance Operation	Maintenance Interval
A – – D E F	Engine oil and oil filter	R	Every 3 000 miles (5 000 km) or 3 months
A B C – E –	Exhaust pipes and mountings	I	Every 6 000 miles (10 000 km) or 6 months
– – – D – –	Air cleaner filter element *1	I	Every 3 000 miles (5 000 km) or 3 months
		R	Every 15 000 miles (25 000 km) or 15 months
– – – – E –	Distributor cap and ignition wiring *2	I	Every 15 000 miles (25 000 km) or 15 months
A B C D – –	Brake discs and pads (Front) Brake drums and shoes (Rear)	I	Every 6 000 miles (10 000 km) or 6 months
A B C – – –	Propeller shafts	I & L	Every 6 000 miles (10 000 km) or 6 months
A – C – – –	Transmission, transfer and differential oil	R	Every 15 000 miles (25 000 km) or 15 months after first replacement at 7 500 miles
– – C – – –	Leaf springs	I	Every 15 000 miles (25 000 km) or 15 months
– – C – – –	Bolts and nuts on chassis	T	Every 6 000 miles (10 000 km) or 6 months
– – C – – –	Steering wheel free play, gear box oil and linkage	I	Every 3 000 miles (5 000 km) or 3 months
– – C – E –	Steering knuckle oil seals	R	Every 15 000 miles (25 000 km) or 15 months

NOTES:

- | | |
|--|--|
| <i>I</i> – Inspect and correct or replace if necessary | <i>T</i> – Tighten to specified torque |
| <i>R</i> – Replace or change | <i>L</i> – Lubricate |

*1 Inspect more frequently if the vehicle is used under dusty conditions.

*2 In areas where road salt is used, inspect and clean the distributor cap and ignition wiring more frequently.

1-2. ENGINE AND EMISSION CONTROL

For maintenance service procedure of any item not found in this section, refer to SECTION 1 of '88 MODEL SERVICE MANUAL.

2. CAMSHAFT TIMING BELT INSPECTION

- 1) Disconnect negative battery lead at battery.
- 2) Loosen fan drive belt, and remove radiator fan shroud and cooling fan & clutch at the same time.

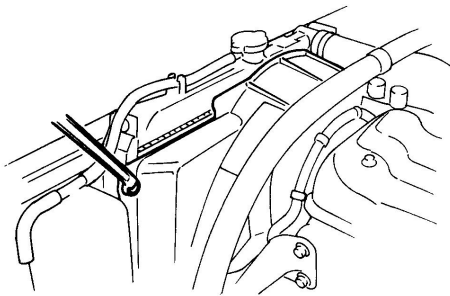

Fig. 1-1 Removing Fan Shroud

- 3) Remove water pump belt and pump pulley.
- 4) Remove crankshaft pulley by removing 4 pulley bolts. The crankshaft timing belt pulley bolt at the center needs not be loosened.

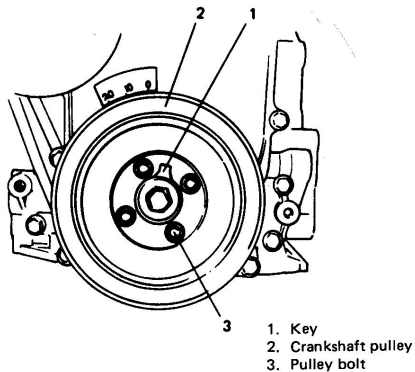

Fig. 1-2 Removing Pulley

- 5) Remove timing belt outside cover. Inspect the belt for damage or wear. When any damage or wear is found on the belt, replace it.

NOTE:

If belt replacement is necessary, be sure to install the belt properly, referring to page 3-6 to page 3-8 of this supplement for installation procedure.

- 6) Install timing belt outside cover and torque bolts and nut to specification.
- 7) Install crankshaft pulley and torque bolts to specification.
- 8) Install water pump pulley and belt.
- 9) Install radiator shroud and cooling fan & clutch
- 10) Adjust water pump belt tension to specification.
- 11) Connect negative battery lead to battery.

9. OXYGEN SENSOR REPLACEMENT

WARNING:

To avoid danger of being burned, do not touch exhaust system when it is still hot. This work should be performed when it is cool.

- 1) Disconnect battery negative cable from battery and disconnect oxygen sensor wire at its coupler.
- 2) Remove oxygen sensor from exhaust manifold.

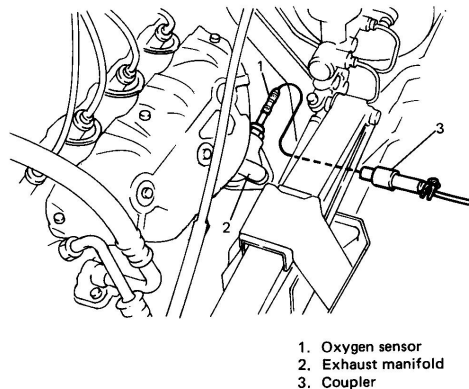

Fig. 1-3 Oxygen sensor

- 3) Install new oxygen sensor, and tighten it to specification.

Tightening torque for oxygen sensor	N-m	kg-m	lb-ft
	45 – 55	4.5 – 5.5	33.0 – 39.5

- 4) Connect oxygen sensor wire at the coupler securely and clamp its wire.
 5) Connect negative cable to battery.
 6) Start engine and check for gas leak.

NOTE:

With Vehicles of Federal specifications except Californian and Canadian specification ones, be sure to turn off "CHECK ENGINE" light with its cancel switch upon completion of service.

10. CATALYTIC CONVERTER INSPECTION

Inspect exhaust center pipe (catalytic converter) for leakage, loose, connections, dents, and damages.

11. CHARCOAL CANISTER REPLACEMENT

WARNING:

The following cautions should be always observed.

- DO NOT smoke and place "NO SMOKING" signs near work area.
- To release fuel vapor pressure in fuel tank, remove fuel tank cap and then reinstall it.

- 1) Disconnect negative battery cable at battery.
- 2) Disconnect purge (vacuum) hose and tank (vapor) hose from canister.
- 3) Remove canister from vehicle body.
- 4) Install new canister by reversing removal procedure.
- 5) Clamp hoses securely.

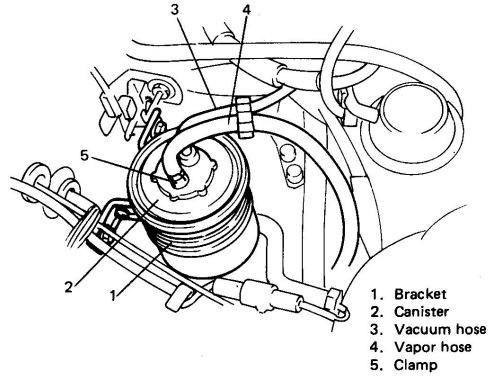

Fig. 1-4 Canister

13. EXHAUST GAS RECIRCULATION (EGR) SYSTEM INSPECTION

Check EGR valve for proper operation. For checking procedures, refer to SECTION 4A of this supplement.

14. ECM AND ASSOCIATED SENSORS INSPECTION

WARNING:

Apply parking brake without fail before this work. With manual transmission vehicle, shift gear shift lever to NEUTRAL position.

- 1) Start engine and warm it up normal operating temperature.

NOTE:

With vehicles of Federal specifications except Californian and Canadian specification ones, be sure to turn off "CHECK ENGINE" light with its cancel switch.

- 2) Stop engine.
- 3) Connect (ground) spare fuse to diagnosis switch terminal.

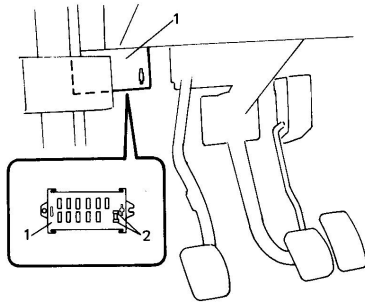

1. Fuse box
2. Diagnosis switch terminal

Fig. 1-5 Diagnosis Switch Terminal

- 4) Run engine at idle speed and check "CHECK ENGINE" light on meter panel as to which number of diagnostic code it indicates.

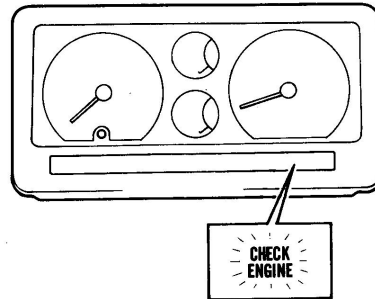

Fig. 1-6 "CHECK ENGINE" Light

- 5) If "CHECK ENGINE" light indicates No. 12 of diagnostic code, ECM and associated sensors are in good condition, but if it indicates any other diagnostic code number, refer to "DIAGNOSIS" of SECTION 4A.
- 6) Stop engine and disconnect spare fuse connected to diagnosis switch terminal in fuse box.

19. IGNITION TIMING INSPECTION

Check to make sure that ignition timing is set properly. If out of specification, adjust it. Refer to SECTION 8 of this supplement for inspection and adjustment procedure.

22. FUEL FILTER REPLACEMENT

WARNING:

This work must be performed in a well ventilated area and away from any open flames (such as gas hot water heaters).

Fuel filter is located at the front part of fuel tank, inside the right-hand side of chassis.

- 1) Disconnect negative cable from battery.
- 2) Replace fuel filter. Be sure to refer to description under FUEL FILTER REMOVAL and INSTALLATION in SECTION 4 (page 4-5) of this supplement for proper procedure.

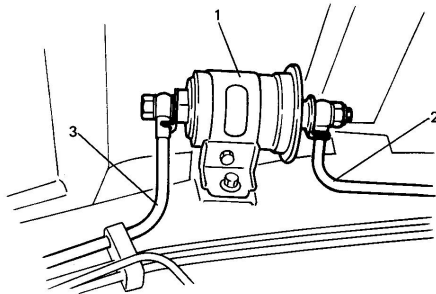

1. Fuel filter
2. Inlet pipe
3. Outlet pipe

Fig. 1-7 Fuel Filter

NOTE:

Torque pipe fastening bolts to specification.

- 3) Connect negative cable to battery.
- 4) After installation, start engine and check it for leaks.

23. FUEL LINES AND CONNECTIONS INSPECTION

Visually inspect fuel lines and connections for evidence of fuel leakage, hose cracking, and damage. Make sure all clamps are secure.

Repair leaky joints, if any.

Replace hoses that are suspected of being cracked.

24. IDLE SPEED INSPECTION

Check idle speed, and adjust it as necessary.

Refer to ON-VEHICLE SERVICE (page 4A-78) of SECTION 4A of this supplement for procedures to check and adjust idle speed.

25. FUEL INJECTOR INSPECTION

- 1) Check injector for resistance, injecting condition and leakage. For checking procedures, refer to Fuel Injection Inspection in SECTION 4A, ELECTRONIC FUEL INJECTION SYSTEM.
- 2) Start engine and check to ensure that engine runs smoothly as its number of revolutions is increased from idle speed to high speed.
- 3) Stop engine.

SECTION 2

TROUBLE SHOOTING

NOTE:

For the items not found in this section (For trouble shooting other than engine), refer to the same section of '88 MODEL SERVICE MANUAL.

2

CONTENTS

2-1. ENGINE	2-2
-------------------	-----

2-1. ENGINE

Condition	Possible Cause	Correction
Hard Starting (Engine cranks OK)	<p>Ignition system out of order.</p> <ul style="list-style-type: none"> • Blown fuse • Faulty spark plug • Leaky high-tension cord • Loose connection or disconnection of high-tension cords or lead wires • Faulty ESA system • Improper ignition timing • Faulty ignition coil • Cracked rotor or cap in distributor • Faulty noise suppressor <p>Fuel system out of order.</p> <ul style="list-style-type: none"> • Lack of fuel in fuel tank • Dirty fuel filter • Dirty or clogged fuel hose or pipe • Malfunctioning fuel pump • Air inhaling from intake manifold gasket or throttle body gasket <p>Electronic Fuel Injection system out of order.</p> <p>Low compression.</p> <ul style="list-style-type: none"> • Poor spark plug tightening or faulty gasket • Incorrect valve lash • Compression leak from valve seat • Sticky valve stem • Weak or damaged valve springs • Compression leak at cylinder head gasket • Sticking or damaged piston ring • Worn piston, ring or cylinder <p>Others</p> <ul style="list-style-type: none"> • Broken valve timing belt • Malfunctioning PCV valve 	<p>Repair or replace.</p> <p>Clean and adjust plug gap or replace.</p> <p>Replace.</p> <p>Repair or replace.</p> <p>Refer to SECTION 8.</p> <p>Adjust.</p> <p>Replace.</p> <p>Replace.</p> <p>Replace.</p> <p>Refill.</p> <p>Replace.</p> <p>Clean.</p> <p>Replace.</p> <p>Replace.</p> <p>Refer to SECTION 4A.</p> <p>Tighten to specified torque or replace gasket.</p> <p>Adjust.</p> <p>Remove cylinder head and lap valves.</p> <p>Correct or replace valve and valve guide.</p> <p>Replace valve springs.</p> <p>Repair or replace.</p> <p>Replace piston rings.</p> <p>Replace ring and piston. Rebore or replace cylinder.</p> <p>Replace.</p> <p>Replace.</p>

Condition	Possible Cause	Correction
<p>Engine has no power.</p>	<p>Low compression.</p> <p>Ignition system out of order.</p> <ul style="list-style-type: none"> • Incorrect ignition timing • Faulty spark plug • Worn distributor terminals • Leaks, loose connection or disconnection of high tension cord • Faulty ESA system <p>Fuel system out of order.</p> <ul style="list-style-type: none"> • Clogged fuel hose or pipe • Dirty or clogged fuel filter • Clogged air cleaner element • Air inhaling from intake manifold gasket or throttle body gasket <p>Electronic Fuel Injection system out of order.</p> <p>Others</p> <ul style="list-style-type: none"> • Loose connection or disconnection of vacuum hoses • Malfunctioning EGR valve • Dragging brakes • Slipping clutch 	<p>Previously outlined.</p> <p>Adjust. Adjust or replace. Dress or replace. Also check rotor. Connect or replace as necessary.</p> <p>Refer to SECTION 8.</p> <p>Clean. Replace. Clean or replace. Replace gasket.</p> <p>Refer to SECTION 4A.</p> <p>Connect securely.</p> <p>Check and replace as necessary. Repair or replace. Adjust or replace.</p>
<p>Improper engine idling or engine fails to idle.</p>	<p>Ignition system out of order.</p> <ul style="list-style-type: none"> • Faulty spark plug • Leaky or disconnected high tension cord • Worn distributor terminals • Improper ignition timing • Cracked cap in distributor, there being leakage inside • Faulty ESA system <p>Fuel system out of order.</p> <ul style="list-style-type: none"> • Shortage of fuel in fuel tank • Clogged air cleaner element • Leaky manifold, throttle body, or cylinder head gasket <p>Electronic Fuel Injection system out of order.</p> <p>Engine overheating.</p> <p>Low compression.</p> <p>Others</p> <ul style="list-style-type: none"> • Loose connection or disconnection of vacuum hoses • Malfunctioning EGR valve • Malfunctioning PCV valve 	<p>Adjust or replace. Connect or replace. Replace. Adjust. Replace.</p> <p>Refer to SECTION 8.</p> <p>Refill. Clean or replace. Replace.</p> <p>Refer to SECTION 4A.</p> <p>Refer to "Overheating" section.</p> <p>Previously outlined.</p> <p>Connect securely.</p> <p>Check and replace as necessary. Check and replace as necessary.</p>

Condition	Possible Cause	Correction
<p>Engine hesitates (Momentary lack of response as accelerator is depressed. Can occur at all vehicle speeds. Usually most severe when first trying to make the vehicle move, as from a stop sign.)</p>	<p>Ignition system out of order.</p> <ul style="list-style-type: none"> ● Improper ignition timing ● Spark plug faulty or plug gap as out of adjustment ● Leaky high tension cord <p>Fuel system out of order.</p> <ul style="list-style-type: none"> ● Clogged air cleaner element ● Clogged fuel filter, hose or pipe <p>Electronic Fuel Injection system out of order.</p> <p>Engine overheating.</p> <p>Low compression.</p> <p>Others</p> <ul style="list-style-type: none"> ● Malfunctioning EGR valve 	<p>Adjust. Replace or adjust gap.</p> <p>Replace.</p> <p>Clean or replace. Clean or replace.</p> <p>Refer to SECTION 4A.</p> <p>Refer to "Overheating" section.</p> <p>Previously outlined.</p> <p>Check and replace as necessary.</p>
<p>Surges (Engine power variation under steady throttle or cruise. Feels like vehicle speeds up and down with no change in the accelerator pedal.)</p>	<p>Ignition system out of order.</p> <ul style="list-style-type: none"> ● Improper ignition timing ● Faulty ESA system ● Leaky or loosely connected high tension cord ● Faulty spark plug (excess carbon deposits, improper gap, and burned electrodes, etc.) ● Cracked rotor or cap in distributor <p>Fuel system out of order.</p> <ul style="list-style-type: none"> ● Clogged fuel filter ● Kinky or damaged fuel hose and lines <p>Electronic Fuel Injection system out of order.</p> <p>Others</p> <ul style="list-style-type: none"> ● Malfunctioning EGR valve 	<p>Adjust. Refer to SECTION 8. Check and repair or replace.</p> <p>Check and clean, adjust or replace.</p> <p>Replace.</p> <p>Replace. Check and replace as necessary.</p> <p>Refer to SECTION 4A.</p> <p>Check and replace as necessary.</p>
<p>Excessive detonation (Engine makes sharp metallic knocks that change with throttle opening. Sounds like pop corn popping.)</p>	<p>Engine overheating.</p> <p>Ignition system out of order.</p> <ul style="list-style-type: none"> ● Faulty spark plug ● Improper ignition timing ● Loose connection of high tension cord 	<p>Refer to the section "Overheating".</p> <p>Replace. Adjust. Connect securely.</p>

Condition	Possible Cause	Correction
	<p>Fuel system out of order.</p> <ul style="list-style-type: none"> • Clogged fuel filter and fuel lines • Air inhaling from intake manifold or throttle body gasket <p>Electronic Fuel Injection system out of order.</p> <p>Others</p> <ul style="list-style-type: none"> • Excessive combustion chamber deposits • Malfunctioning EGR valve 	<p>Replace or clean. Replace.</p> <p>Refer to SECTION 4A.</p> <p>Remove carbon. Check and replace as necessary.</p>
Overheating	<ul style="list-style-type: none"> • Insufficient coolant • Loose water pump belt • Inoperative thermostat • Poor water pump performance • Improper ignition timing • Clogged or leaky radiator • Improper engine oil grade • Clogged oil filter or oil strainer • Not enough oil • Poor oil pump performance • Oil leakage • Dragging brakes • Slipping clutch • Blown cylinder head gasket 	<p>Replenish. Adjust. Replace. Replace. Adjust. Flush, repair or replace. Replace with proper grade oil. Replace or clean (oil strainer). Replenish. Repair or replace. Repair. Repair or replace. Adjust or repair. Replace.</p>
Poor gasoline mileage.	<p>Fuel system out of order.</p> <ul style="list-style-type: none"> • Fuel leakage from fuel tank and lines • Clogged air cleaner element <p>Ignition system out of order.</p> <ul style="list-style-type: none"> • Improper ignition timing • Leaks or loose connection of high tension cord • Faulty spark plug (improper gap, heavy deposits, and burned electrodes, etc..) • Faulty ESA system <p>Electronic Fuel Injection system out of order.</p>	<p>Repair or replace. Clean or replace.</p> <p>Adjust. Repair or replace.</p> <p>Clean, adjust or replace.</p> <p>Refer to SECTION 8.</p> <p>Refer to SECTION 4A.</p>

Condition	Possible Cause	Correction
	<p>Low compression</p> <p>Others</p> <ul style="list-style-type: none"> • Poor valve seating • Dragging brakes • Slipping clutch • Thermostat out of order • Improper tire pressure • Malfunctioning EGR valve 	<p>Previously outlined.</p> <p>Repair or replace.</p> <p>Repair or replace.</p> <p>Adjust or replace.</p> <p>Replace.</p> <p>Adjust.</p> <p>Check and replace as necessary.</p>
<p>Excessive engine oil consumption</p>	<p>Oil leakage</p> <ul style="list-style-type: none"> • Loose oil drain plug • Loose oil pan bolts • Deteriorated or broken oil pan sealant • Leaky crankshaft oil seals • Leaky cylinder head cover gasket • Improper tightening of oil filter • Loose oil pressure switch • Blown cylinder head gasket • Leaky camshaft oil seals <p>Oil entering combustion chamber</p> <ul style="list-style-type: none"> • Sticky piston ring • Worn piston and cylinder • Worn piston ring groove and ring • Improper location of piston ring gap • Worn or damaged valve stem seal • Worn valve stem 	<p>Tighten.</p> <p>Tighten.</p> <p>Replace sealant.</p> <p>Replace.</p> <p>Replace.</p> <p>Tighten.</p> <p>Tighten.</p> <p>Replace.</p> <p>Replace.</p> <p>Remove carbon and replace rings.</p> <p>Replace or rebore cylinder, and replace piston.</p> <p>Replace piston and ring.</p> <p>Reposition ring gap.</p> <p>Replace.</p> <p>Replace.</p>
<p>Low oil pressure</p>	<ul style="list-style-type: none"> • Not enough oil • Improper oil viscosity • Malfunctioning oil pressure switch • Clogged oil strainer • Functional deterioration of oil pump • Worn oil pump relief valve • Excessive clearance in various sliding parts 	<p>Replenish.</p> <p>Use oil of proper viscosity.</p> <p>Replace.</p> <p>Clean.</p> <p>Replace.</p> <p>Replace.</p> <p>Replace worn parts.</p>

Condition	Possible Cause	Correction
<p>Engine noise Note: Before checking mechanical noise, make sure that:</p> <ul style="list-style-type: none"> • Ignition timing is properly adjusted. • Specified spark plug is used. • Specified fuel is used. 	<p>Valve noise</p> <ul style="list-style-type: none"> • Improper valve lash • Worn valve stem and guide • Weak or broken valve spring • Warped or bent valve <p>Piston, ring and cylinder noise</p> <ul style="list-style-type: none"> • Worn piston, ring and cylinder bore <p>Connecting rod noise</p> <ul style="list-style-type: none"> • Worn rod bearing • Worn crank pin • Loose connecting rod nuts • Low oil pressure <p>Crankshaft noise</p> <ul style="list-style-type: none"> • Low oil pressure • Worn bearing • Worn crankshaft journal • Loose bearing cap bolts • Excessive crankshaft thrust play 	<p>Adjust. Replace. Replace. Replace.</p> <p>Rebore or replace cylinder. Replace piston and ring.</p> <p>Replace. Repair by grinding or replace crankshaft.</p> <p>Tighten nuts to specification. Previously outlined.</p> <p>Previously outlined. Replace. Repair by grinding, or replace crankshaft.</p> <p>Tighten bolts to specification. Replace thrust bearing.</p>

SECTION 3

ENGINE

NOTE:

For the items not found in this section, refer to the same section of '88 MODEL SERVICE MANUAL.

3

CONTENTS

3-1. GENERAL DESCRIPTION	3- 2
3-5. INSPECTION OF ENGINE COMPONENTS	3- 4
3-6. ENGINE REASSEMBLY	3- 5
3-8. ENGINE MAINTENANCE SERVICE	3- 9
3-9. RECOMMENDED TORQUE SPECIFICATIONS	3-12

WARNING:

The '90 – '93 model vehicle is equipped with the Electronic Fuel Injection system. As "3-1. GENERAL DESCRIPTION" provides important information on it and precautions to be taken, read it carefully before servicing the engine and make sure to observe precautions.

3-1. GENERAL DESCRIPTION

As the Electronic Fuel Injection system is used for the '90 – '93 model vehicles to improve its engine output, the '90 – '93 models engine differs from '88 and '89 model ones. Main differences among others are as follows.

- Crankshaft Piston stroke is different.
- Piston Shape of piston head is different.
- Camshaft Cam height and valve timing are different.
- Tensioner plate Shape is different.

GENERAL INFORMATION ON ENGINE SERVICE

THE FOLLOWING INFORMATION ON ENGINE SERVICE SHOULD BE NOTED CAREFULLY, AS IT IS IMPORTANT IN PREVENTING DAMAGE, AND IN CONTRIBUTING TO RELIABLE ENGINE PERFORMANCE.

- When raising or supporting engine for any reason, do not use a jack under oil pan. Due to small clearance between oil pan and oil pump strainer, jacking against oil pan may cause it to be bent against strainer resulting in damaged oil pick-up unit.
- It should be kept in mind, while working on engine, that 12-volt electrical system is capable of violent and damaging short circuits. When performing any work where electrical terminals could possibly be grounded, ground cable of the battery should be disconnected at battery.
- Any time the air cleaner, air intake case, throttle body or intake manifold is removed, the intake opening should be covered. This will protect against accidental entrance of foreign material which could follow intake passage into cylinder and cause extensive damage when engine is started.
- When disconnecting couplers, don't pull wire harness but make sure to hold coupler itself. With lock type coupler, be sure to unlock the lock before disconnection. With spring lock type coupler as shown in Fig. 3-1, push out

spring before disconnection, but only within the extent that spring is not deformed. Attempt to disconnect coupler without unlocking may result in damage to coupler. When connecting lock type coupler, insert it till clicking sound is heard and connect it securely.

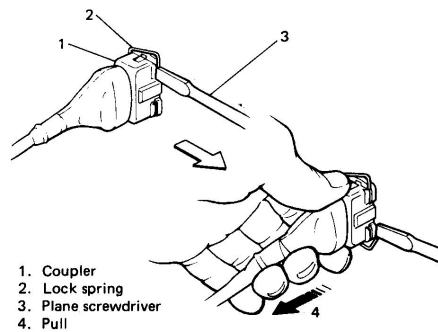

Fig. 3-1 Disconnection of Spring Lock Type Coupler

PRECAUTION ON FUEL SYSTEM SERVICE

- Work must be done with no smoking, in a well-ventilated area and away from any open flames.
- As fuel feed line (between fuel pump and fuel pressure regulator) is still under high fuel pressure even after engine was stopped, loosening or disconnecting fuel feed line directly may cause dangerous spout of fuel to occur where loosened or disconnected. Before loosening or disconnecting fuel feed line, make sure to release fuel pressure according to "FUEL PRESSURE RELIEF PROCEDURE". A small amount of fuel may be released after the fuel line is disconnected. In order to reduce the chance of personal injury, cover the fitting to be disconnected with a shop cloth. Put that cloth in an approved container when disconnection is completed.

- Never run engine with fuel pump relay disconnected when engine and exhaust system are hot.
- Fuel or fuel vapor hose connection varies with each type of pipe. When reconnecting fuel or fuel vapor hose, be sure to connect and clamp each hose correctly referring to Fig. 3-2 Hose Connection. After connecting, make sure that it has no twist or kink.

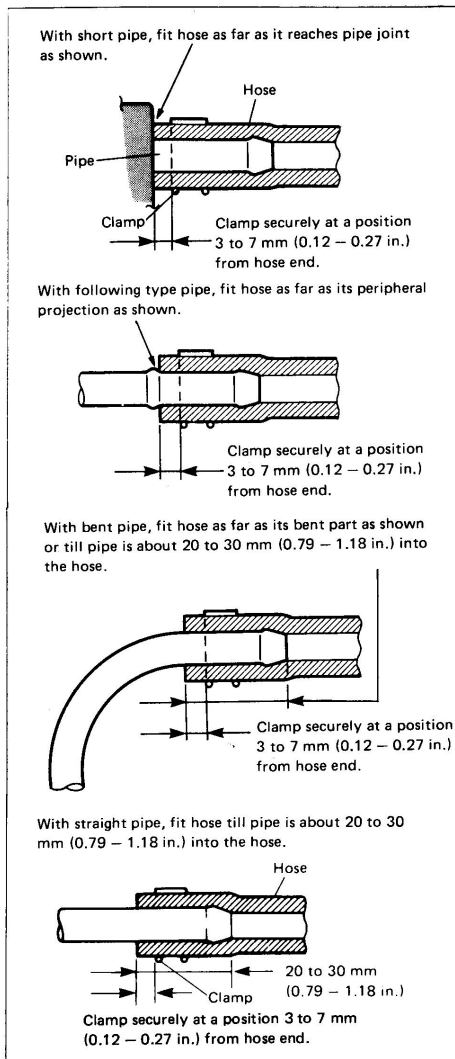

Fig. 3-2 Hose Connection

- When installing fuel filter union bolt or plug bolt on union bolt, always use new gasket and tighten it to specified torque. See Section 4 for specified torque.
- When installing injector, fuel feed pipe or fuel pressure regulator, lubricate its O ring with spindle oil or gasoline.
- When connecting fuel pipe flare nut, first tighten flare nut by hand and then tighten it to specified torque.

FUEL PRESSURE RELIEF PROCEDURE

CAUTION:

This work must not be done when engine is hot. If done so, it may cause adverse effect to catalyst.

After making sure that engine is cold, relief fuel pressure as follows.

1. Place transmission gear shift lever in "Neutral", set parking brake, and block drive wheels.
2. Disconnect coupler from fuel pump relay.
3. Remove fuel filler cap to release fuel vapor pressure in fuel tank and then reinstall it.
4. Start engine and run it till it stops for lack of fuel. Repeat cranking engine 2 - 3 times of about 3 seconds each time to dissipate fuel pressure in lines. Fuel connections are now safe for servicing.
5. Upon completion of servicing, connect coupler to fuel pump relay.

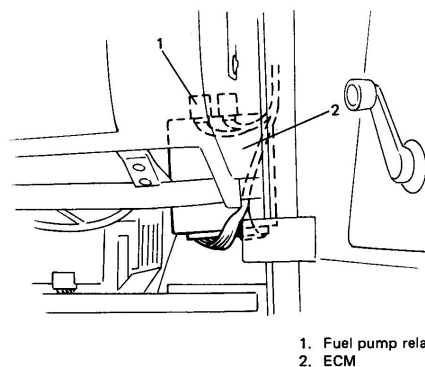

Fig. 3-3 Fuel Pump Relay

FUEL LEAKAGE CHECK PROCEDURE

After performing any service on fuel system, check to make sure that there are no fuel leakages as follows.

1. Turn ON ignition switch for 3 seconds (to operate fuel pump) and then turn it OFF. Repeat this (ON and OFF) 3 or 4 times and apply fuel pressure to fuel line (till fuel pressure is felt by hand placed on fuel return hose).
2. In this state, check to see that there are no fuel leakages from any part of fuel system.

3-5. INSPECTION OF ENGINE COMPONENTS

NOTE:

For the inspection not found in this section, refer to the same section of '88 MODEL SERVICE MANUAL.

Camshaft

- Cam wear:

Using a micrometer, measure height (H) of cam (lobe). If measured height is less than limits, replace camshaft.

Cam height	Standard	Limit
Intake cam	38.136 mm (1.5014 in.)	38.036 mm (1.4975 in.)
Exhaust cam	38.136 mm (1.5014 in.)	38.036 mm (1.4975 in.)

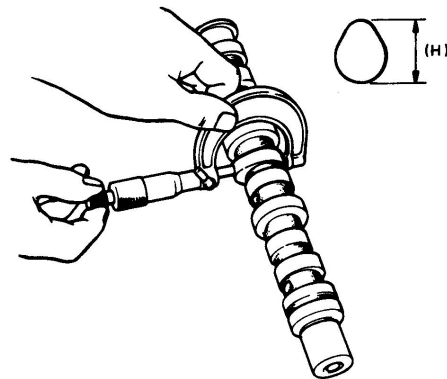

Fig. 3-4 Checking Cam Height

3-6. ENGINE REASSEMBLY

NOTE:

For the assembly procedure not found in this section, refer to the same section of '88 MODEL SERVICE MANUAL.

Piston Ring

- As indicated in figure below, 1st and 2nd rings have "R" or "T" mark. When installing these piston rings to piston, direct marked side of each ring toward top of piston.

NOTE:

There are 2 types of 1st ring, marked and unmarked. When installing a new unmarked 1st ring, it is not necessary to distinguish its top from bottom (i.e., either side can face upward) but when reinstalling a used one, be sure to distinguish its top from bottom as it was installed before removal and direct topside upward.

- 1st ring differs from 2nd ring in thickness, shape and color of surface contacting cylinder wall. Distinguish 1st ring from 2nd ring by referring to figure below.
- When installing oil ring, install spacer first and then two rails.

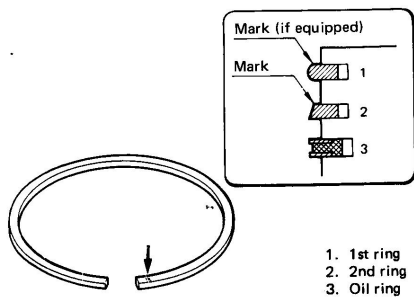

Fig. 3-5 Installing Piston Rings

Cylinder Head

- After applying engine oil to cylinder head bolts, tighten them gradually with a torque wrench, following sequence given in below figure. Finally tighten bolts to specified torque.

Tightening torque for cylinder head bolts	N-m	kg-m	lb-ft
	70 - 75	7.0 - 7.5	51.0 - 54.0

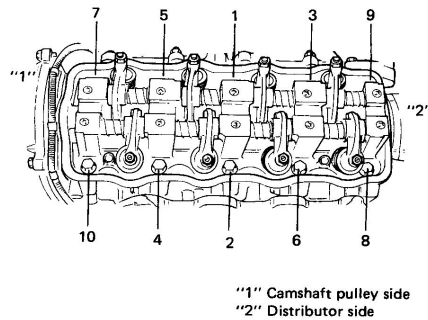

Fig. 3-6 Tightening Sequence of Cylinder Head Bolts

NOTE:

Whenever installing cylinder head to new cylinder block, use following procedure to tighten cylinder head bolts.

- Tighten cylinder head bolts to specified torque as previously outlined and loosen them once till tightening torque becomes "zero". And then torque them to specification again.

Timing Belt Pulleys, Timing Belt and Tensioner

1. Camshaft timing belt pulley

Install timing belt guide, key, and crankshaft timing belt pulley.

Refer to figure below for proper installation of these parts.

Install timing belt guide in such a way that its concave side faces oil pump.

With crankshaft locked, tighten crankshaft timing belt pulley torque.

Tightening torque for crankshaft timing belt pulley bolt	N-m	kg-m	lb-ft
	105-115	10.5-11.5	76.0-83.0

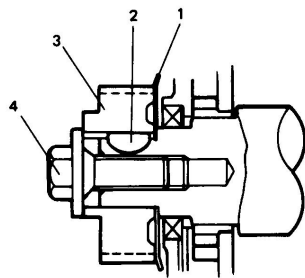

- 1. Timing belt guide
- 2. Key
- 3. Crankshaft timing belt pulley
- 4. Pulley bolt

Fig. 3-7 Installing Guide, Key and Pulley

2. Camshaft timing belt pulley.

Fit pulley pin on camshaft into slot on camshaft pulley. With camshaft locked, tighten the pulley bolt to the specified torque.

Tightening torque for camshaft timing belt pulley bolt	N-m	kg-m	lb-ft
	56 - 64	5.6 - 6.4	41.0 - 46.0

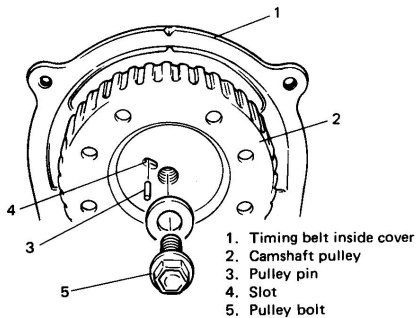
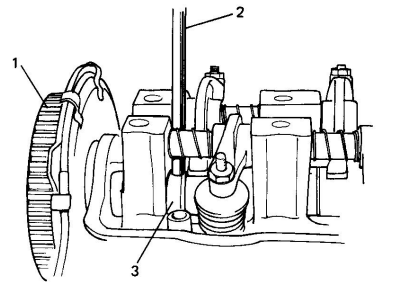

Fig. 3-8 Pulley Pin, Slot and Pulley Bolt

3-6



- 1. Camshaft timing belt pulley
- 2. Proper size rod
- 3. Camshaft

Fig. 3-9 Locking Camshaft

3. Tensioner and timing belt

1) Insert lug of tensioner plate into hole of tensioner.

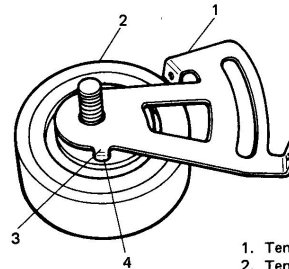

- 1. Tensioner plate
- 2. Tensioner
- 3. Lug
- 4. Hole

Fig. 3-10 Lug and Hole

2) Tensioner, tensioner plate, spring and spring damper:

Do not tighten the tensioner bolt and stud by wrench yet. Hand tighten only at this time.

Check to ensure that the plate movement in arrow direction as shown in below figure causes the same directional movement of the tensioner.

If no associated movement between plate and tensioner occurs, remove tensioner and plate again and reinsert the plate lug into tensioner hole.

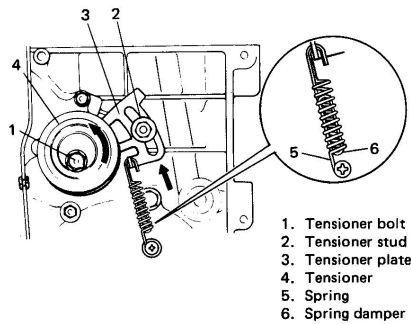

Fig. 3-11 Tensioner Installation

- 3) Before installing timing belt to camshaft timing belt pulley and crankshaft timing belt pulley, loosen all valve adjusting screws of intake and exhaust rocker arms fully, or check to ensure they are loose. This is to permit free rotation of camshaft for the reason is; when installing timing belt to both pulleys, belt should be correctly tensed by tensioner spring force. If camshaft does not rotate freely, belt will not be correctly tensed by tensioner.

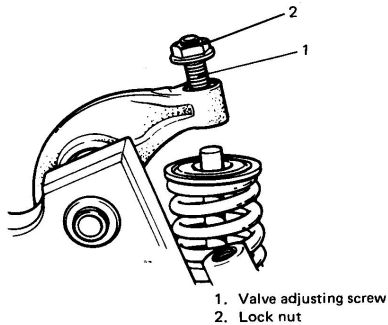

Fig. 3-12 Valve Adjusting Screw and Lock Nut

- 4) After loosening all valve adjusting screws all the way, turn camshaft pulley clockwise and align timing mark on camshaft pulley with "V" mark on the belt inside cover as shown in figure below.

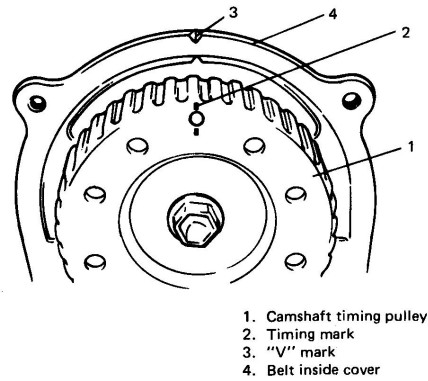

Fig. 3-13 Timing Marks

- 5) Turn crankshaft clockwise, fitting 17 mm wrench to crank timing belt pulley bolt, and align punch mark on timing belt pulley with the arrow mark on oil pump as shown in below figure.

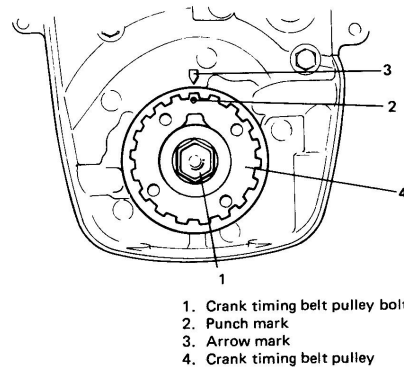

Fig. 3-14 Timing Marks

6) With two sets of marks aligned, install timing belt on two pulleys in such a way that the drive side of belt is free of any slack, and with tensioner plate pushed up by finger.

NOTE:

- When installing timing belt, match arrow mark (⇒) on timing belt with rotating direction of crankshaft.
- In this state, No. 4 piston is at top dead center of compression stroke.

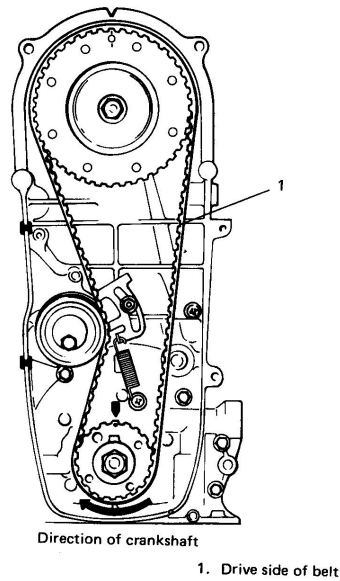

Fig. 3-15 Installing Timing Belt

7) To take up slack of timing belt, turn crankshaft two rotations clockwise after installing it. After making sure that belt is free from slack, tighten tensioner stud first and then tensioner bolt to each specified torque. Then confirm again that two sets of marks are aligned respectively.

Tightening torque for tensioner stud	N-m	kg-m	lb-ft
	9 – 12	0.9 – 1.2	7.0 – 8.5
Tightening torque for tensioner bolt	N-m	kg-m	lb-ft
	24 – 30	2.4 – 3.0	17.5 – 21.5

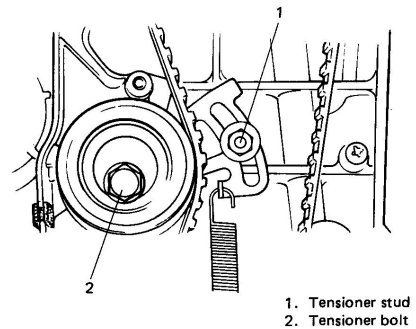

Fig. 3-16 Tensioner Bolt and Stud

3-8. ENGINE MAINTENANCE SERVICE

NOTE:

For the maintenance service procedure not found in this section, refer to the same section of '88 MODEL SERVICE MANUAL.

Compression Pressure Measurement

Check compression pressure on all four cylinders as follows:

1. Warm up engine.
2. Stop engine after warming up.
3. Disconnect CAS coupler.

WARNING:
Failure in disconnecting CAS coupler can cause spark to occur in engine room possibly resulting in a dangerous explosion.

4. Remove all 4 spark plugs.
5. Install special tool (Compression gauge) into spark plug hole.

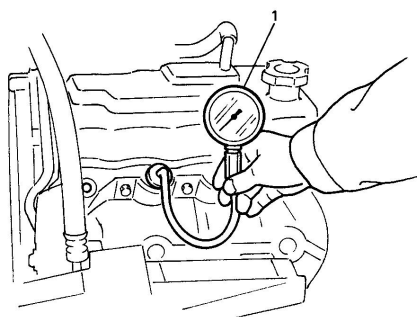

1. Special tool (Compression gauge 09915-64510)

Fig. 3-17 Installing Compression Gauge

6. Disengage clutch to lighten starting load on engine and depress accelerator pedal all the way to make throttle fully open.
7. Crank engine with fully charged battery, and read the highest pressure on compression gauge.

NOTE:

For measuring compression pressure, crank engine at least 250 r/min by using fully charged battery.

Compression pressure at sea level	
Standard	14.0 kg/cm ² (199.0 psi, 1400 kPa)
Limit	12.0 kg/cm ² (170.0 psi, 1200 kPa)
Max. difference between any two cylinders	1.0 kg/cm ² (14.2 psi, 100 kPa)

8. Carry out steps 5 through 7 on each cylinder to obtain four readings.
9. After checking, install spark plugs, high-tension cords and connect CAS coupler.

Vacuum Measurement

The engine vacuum that develops in the intake line is a good indicator of the condition of the engine. The vacuum checking procedure is as follows:

1. Warm up engine to normal operating temperature and make sure that engine idle speed is within specification.
2. Stop engine and disconnect vacuum hoses from throttle opener VSV.
3. Connect vacuum pump to vacuum hose of opener side.
4. Connect special tools (vacuum gauge and hose joint) to vacuum hose of intake manifold side.

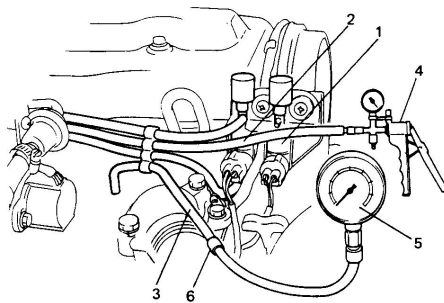

- | | |
|--|-------------------------------|
| 1. Throttle opener VSV | 4. Vacuum pump (09917-47910) |
| 2. Vacuum hose of opener side | 5. Vacuum gauge (09915-67310) |
| 3. Vacuum hose of intake manifold side | 6. Hose joint (09918-08210) |

Fig. 3-18 Installing Vacuum Gauge

5. Start engine and apply -40 cmHg vacuum to throttle opener to run engine at specified idle speed, and read vacuum gauge. Vacuum should be within specification.

Vacuum specification (sea level)	45 – 55 cm Hg (17.7 – 21.6 in. Hg) at 800 r/min
----------------------------------	---

6. After checking, remove vacuum pump, vacuum gauge and hose joint.
7. Connect vacuum hoses to throttle opener VSV.

3-10

Valve Lash (Clearance)

Valve lash specifications

Valve lash refers to gap between rocker arm adjusting screw and valve stem. Use a thickness gauge to measure this gap (A).

Valve lash (gap A) specification		When cold (Coolant temperature is 15 – 25°C or 59 – 77°F)	When hot (Coolant temperature is 60 – 68°C or 140 – 154°F)
		Intake	0.13 - 0.18 mm (0.0051 - 0.0071 in)
	Exhaust	0.15 - 0.21 mm (0.0059 - 0.0083 in)	0.26 - 0.30 mm (0.0102 - 0.0118 in)

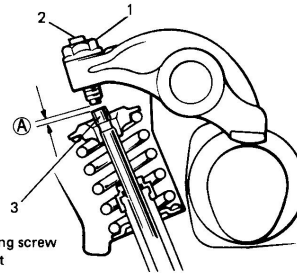

1. Adjusting screw lock nut
2. Adjusting screw
3. Valve stem

Fig. 3-19

Checking and adjusting procedures

1. Disconnect negative cable at battery.
2. Turn crankshaft pulley clockwise until "V" mark on pulley aligns with "0" (zero) on timing belt cover.

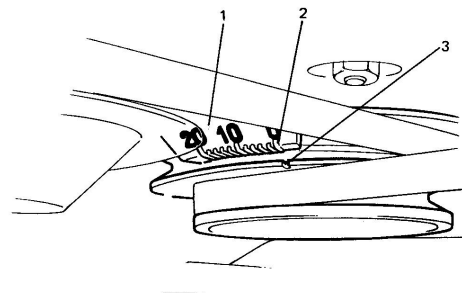

1. Timing tab (belt cover)
2. "0" mark
3. "V" mark (timing notch) on crankshaft pulley

Fig. 3-20 Aligning Marks

- Remove distributor cap, and check if rotor is positioned as shown in figure. (i.e. No. 1 piston is at TDC of compression stroke). If rotor is out of place, turn crankshaft clockwise once (360°). In this state, check valve lashes at valves ①, ②, ⑤, and ⑦.

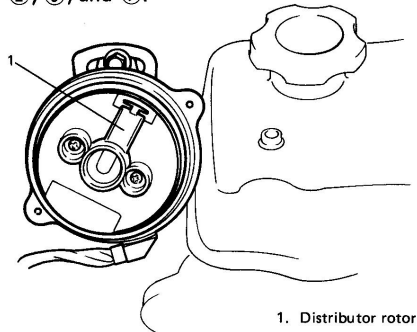

Fig. 3-21 Checking Rotor Position

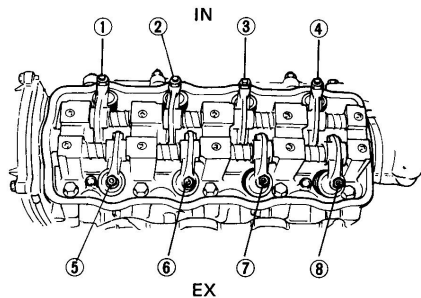

Fig. 3-22 Valve Identification

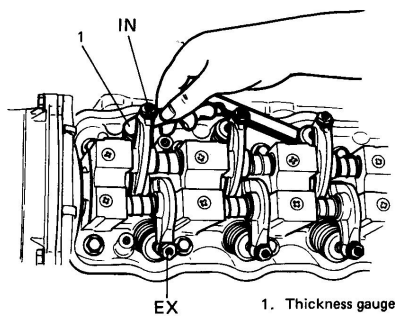

Fig. 3-23 Checking Valve Lashes

- If valve lash is out of specification, adjust it to specification by turning adjusting screw after loosening lock nut. After adjustment, tighten lock nut to specified torque while holding adjusting screw stationary with screwdriver, and then make sure again that valve lash is within specification.

Tightening torque for adjusting screw lock nut	N·m	kg·m	lb·ft
	15 - 19	1.5 - 1.9	11.0 - 13.5

- After checking and adjusting valve lashes at valves ①, ②, ⑤ and ⑦, rotate crankshaft exactly one full turn (360°), and check the same at valves ③, ④, ⑥ and ⑧. Adjust them as necessary.
- After checking and adjusting all valves, install cylinder head cover and distributor cap.

3-9. RECOMMENDED TORQUE SPECIFICATIONS

Fastening parts	Tightening torque		
	N·m	kg·m	lb·ft
1. Cylinder head bolt	70 – 75	7.0 – 7.5	51.0 – 54.0
2. Cylinder head cover bolt	4 – 5	0.4 – 0.5	3.0 – 3.5
3. Spark plug	20 – 30	2.0 – 3.0	14.5 – 21.5
4. Distributor gear case	8 – 12	0.8 – 1.2	6.0 – 8.5
5. Rocker arm shaft screw	9 – 12	0.9 – 1.2	7.0 – 8.5
6. Valve adjusting screw lock nut	15 – 19	1.5 – 1.9	11.0 – 13.5
7. Crankshaft main bearing cap bolt	50 – 57	5.0 – 5.7	36.5 – 41.0
8. Oil filter stand	20 – 25	2.0 – 2.5	14.5 – 18.0
9. Oil filter Ass'y	12 – 16	1.2 – 1.6	9.0 – 11.5
10. Oil pressure switch	12 – 15	1.2 – 1.5	9.0 – 10.5
11. Oil drain plug	30 – 40	3.0 – 4.0	22.0 – 28.5
12. Oil pan bolt and nut	9 – 12	0.9 – 1.2	7.0 – 8.5
13. Oil pump strainer bolt	9 – 12	0.9 – 1.2	7.0 – 8.5
14. Water pump bolt and nut	9 – 12	0.9 – 1.2	7.0 – 8.5
15. Cooling fan nut	8 – 12	0.8 – 1.2	6.0 – 8.5
16. Flywheel bolt	57 – 65	5.7 – 6.5	41.5 – 47.0
17. Oil seal housing bolt	9 – 12	0.9 – 1.2	7.0 – 8.5
18. Connecting rod bearing cap nut	33 – 37	3.3 – 3.7	24.0 – 26.5
19. Crankshaft pulley bolt	10 – 13	1.0 – 1.3	7.5 – 9.0
20. Crankshaft timing belt pulley bolt	105 – 115	10.5 – 11.5	76.0 – 83.0
21. Timing belt cover bolt and nut	9 – 12	0.9 – 1.2	7.0 – 8.5
22. Camshaft timing pulley bolt	56 – 64	5.6 – 6.4	41.0 – 46.0
23. Timing belt tensioner bolt	24 – 30	2.4 – 3.0	17.5 – 21.5
24. Timing belt tensioner stud	9 – 12	0.9 – 1.2	7.0 – 8.5
25. Oil pump case bolt	9 – 12	0.9 – 1.2	7.0 – 8.5
26. Oil pump rotor plate screw	9 – 12	0.9 – 1.2	7.0 – 8.5
27. Inlet & exhaust manifold nut	18 – 28	1.8 – 2.8	13.5 – 20.0
28. Engine mounting bracket frame side bolt	40 – 60	4.0 – 6.0	29.0 – 43.0
29. Engine mounting bracket engine side bolt	50 – 60	5.0 – 6.0	36.5 – 43.0
30. Engine mounting nut	40 – 50	4.0 – 5.0	29.0 – 36.0
31. Transmission mounting bracket bolt	18 – 28	1.8 – 2.8	13.5 – 20.0
32. Transmission mounting bolt	18 – 28	1.8 – 2.8	13.5 – 20.0
33. Transmission mounting and frame bolt	18 – 28	1.8 – 2.8	13.5 – 20.0
34. Propeller shaft flange bolt and nut	50 – 60	5.0 – 6.0	36.5 – 43.0

SECTION 4

FUEL SYSTEM

NOTE:

For the items not found in this section, refer to the same section of '88 MODEL SERVICE MANUAL.

4

CONTENTS

4-3. FUEL TANK, PUMP, FILTER AND LINES	4-2
GENERAL DESCRIPTION	4-2
Fuel Tank	4-3
Fuel Pump	Refer to section 4A of GROUP 1.
Fuel Filter	4-3
ON VEHICLE SERVICE	4-4
Fuel Pump	Refer to section 4A of GROUP 1.
Fuel Filter	4-5
Fuel Lines	4-5
Fuel Tank	4-6
RECOMMENDED TORQUE SPECIFICATIONS	4-8

CAUTION:

THE ENGINE OF THIS VEHICLE REQUIRES THE USE OF UNLEADED FUEL ONLY. USE OF LEADED AND/OR LOW LEAD FUEL CAN RESULT IN ENGINE DAMAGE AND REDUCE THE EFFECTIVENESS OF THE EMISSION CONTROL SYSTEMS.

4-1

4-3. FUEL TANK, PUMP, FILTER AND LINES

GENERAL DESCRIPTION

The main components of the fuel system are fuel tank, fuel pump, fuel filter and fuel level gauge and it includes three lines; fuel feed line, fuel return line and fuel vapor line.

For the details of fuel flow and fuel vapor flow, refer to SECTION 4A "ELECTRONIC FUEL INJECTION SYSTEM" and SECTION 5 "EMISSION CONTROL SYSTEM" respectively.

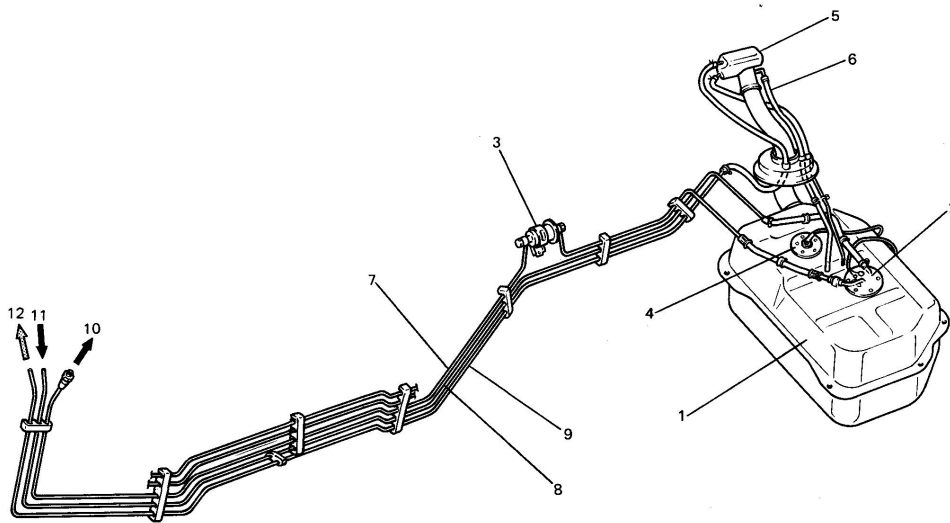

1. Fuel tank
2. Fuel pump
3. Fuel filter
4. Fuel level gauge
5. Vapor liquid separator
6. Breather hose
7. Fuel feed line
8. Fuel return line
9. Fuel vapor line
10. To throttle body
11. From fuel pressure regulator
12. To canister

Fig. 4-1 Fuel Lines

FUEL TANK

The fuel tank is located under the rear of the vehicle. The fuel pump and fuel level gauge are installed on the upper part of the fuel tank.

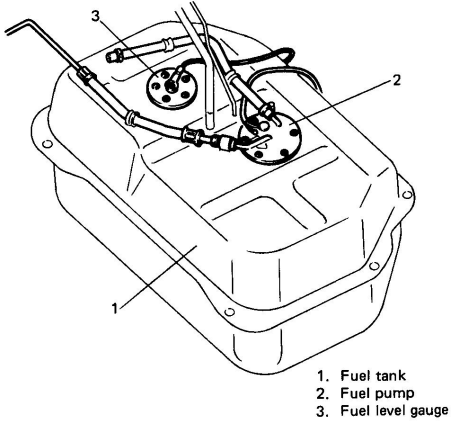

Fig. 4-2 Fuel Tank

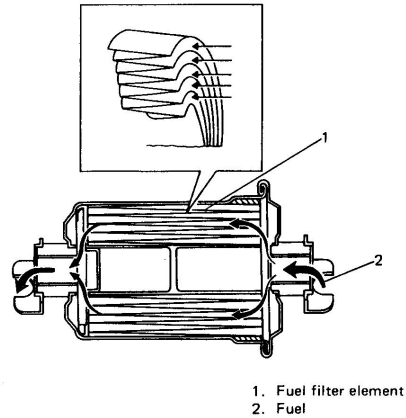

Fig. 4-4 Fuel Filter Element

FUEL FILTER

The fuel filter is installed on the chassis frame and filters the fuel sent under pressure from the fuel pump.

As it can't be disassembled, it should be replaced as an assembly. Note that letters indicating the fuel inlet and outlet ports are stamped on the fuel filter. Refer to them for proper hose connection.

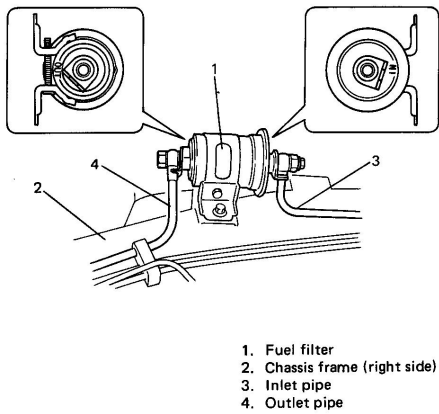

Fig. 4-3 Fuel Filter

ON VEHICLE SERVICE

WARNING:

Before attempting service of any type on fuel system, following cautions should be always observed.

- Disconnect negative cable at battery.
- DO NOT smoke, and place "NO SMOKING" signs near work area.
- Be sure to have CO₂ fire extinguisher handy.
- Be sure to perform work in a well-ventilated area and away from any open flames (such as gas hot heater).
- Wear safety glasses.
- To release fuel vapor pressure in fuel tank, remove fuel filler cap from fuel filler neck and then reinstall it.
- As fuel feed line is still under high fuel pressure even after engine was stopped, loosening or disconnecting fuel feed line directly may cause dangerous spout of fuel to occur where loosened or disconnected. Before loosening or disconnecting fuel feed line, make sure to release fuel pressure according to "FUEL PRESSURE RELIEF PROCEDURE" in p. 3-3. A small amount of fuel may be released after the fuel line is disconnected. In order to reduce the chance of personal injury, cover the fitting to be disconnected with a shop cloth. Put that cloth in an approved container when disconnection is completed.
- Note that fuel hose connection varies with each type of pipe. Be sure to connect and clamp each hose correctly referring to the following.

With short pipe, fit hose as far as it reaches pipe joint as shown.

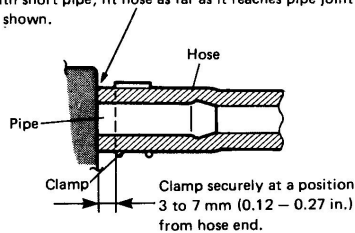

4-4

With following type pipe, fit hose as far as its peripheral projection as shown.

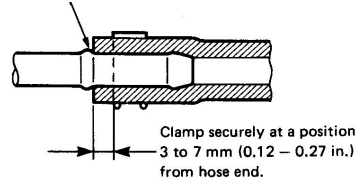

With bent pipe, fit hose as far as its bent part as shown or till pipe is about 20 to 30 mm (0.79 - 1.18 in.) into the hose.

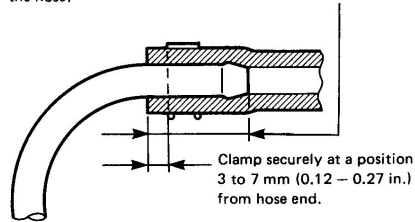

With straight pipe, fit hose till pipe is about 20 to 30 mm (0.79 - 1.18 in.) into the hose.

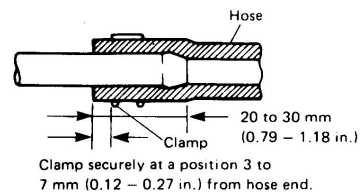

- When connecting fuel feed hose to throttle body, lubricate its O ring with spindle oil or gasoline.
- When connecting fuel pipe flare nut, first tighten flare nut by hand and then tighten it to specified torque.

FUEL FILTER

Remove or Disconnect

1. After making sure that engine is cold, release fuel pressure in fuel feed line referring to "FUEL PRESSURE RELIEF PROCEDURE" in p. 3-3.

CAUTION:

This work must not be done when engine is hot.

2. Negative cable at battery.
3. Fuel filter cap from fuel filter neck to release fuel vapor pressure in fuel tank. After releasing, reinstall cap.
4. Hoist vehicle.
5. Place fuel container under fuel filter.
6. Inlet and outlet pipes from fuel filter by using two wrenches.

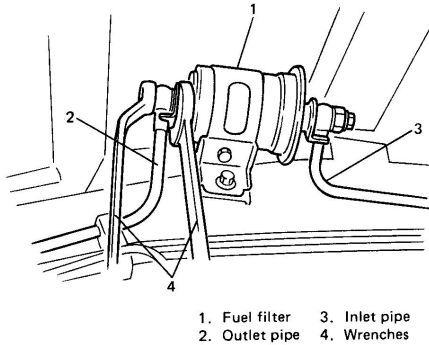

Fig. 4-5 Disconnecting Pipes

7. Fuel filter from chassis frame.

Install or Connect

Reverse removal procedure noting the following.

- Use new gaskets.
- Make sure that gasketed surfaces are free from any damage.
- Inlet and outlet pipes should come into recess of plate as shown below.

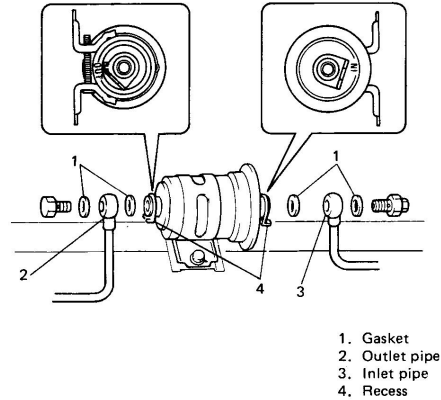

Fig. 4-6 Fuel Filter Installation

- Tighten union bolts to specified torque.

Tightening torque of fuel filter union bolts	N·m	kg·m	lb·ft
	30 - 40	3.0 - 4.0	22.0 - 28.5

- Upon completion of installation, verify that there is no fuel leakage at each connection according to procedure described in p. 3-4.

FUEL LINES

Due to the fact that fuel feed line is under high pressure, this system requires special consideration for service.

The feed pipe uses screw couplings.

Any time these fittings are loosened to service or replace components, ensure that:

- Backup wrench is used while loosening and tightening fitting.
- First tighten fittings (flare nut) by hand and then tighten it to specified torque.

Tightening torque for pipe fitting (flare nut)	N·m	kg·m	lb·ft
	30 - 40	3.0 - 4.0	22.0 - 28.5

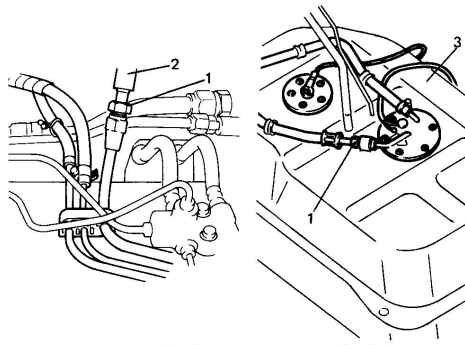

- 1. Flare nut
- 2. To throttle body
- 3. Fuel tank

Fig. 4-7 Fuel Pipe Screw Couplings

Inspect

Visually inspect fuel lines for evidence of fuel leakage, hose cracking and deterioration, or damage. Make sure all clamps are secure. Replace parts as needed.

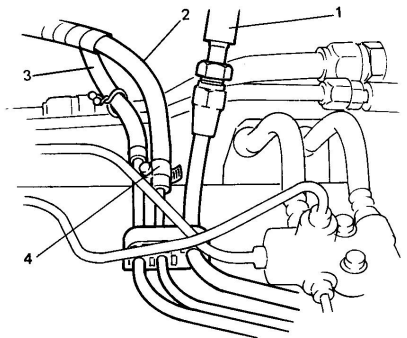

- 1. Fuel feed hose
- 2. Fuel return hose
- 3. Fuel vapor hose
- 4. Clamp

Fig. 4-8 Fuel Lines Inspection

FUEL TANK

Remove or Disconnect

1. Release fuel pressure in fuel feed line referring to "FUEL PRESSURE RELIEF PROCEDURE" in p. 3-3.
2. To release pressure in fuel tank, remove fuel filler cap and then, reinstall it.
3. Negative cable at battery.
4. Fuel level gauge and fuel pump lead wire couplers.

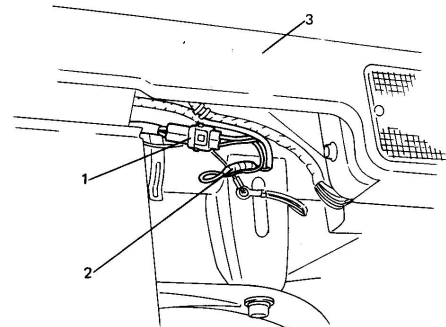

- 1. Fuel pump coupler
- 2. Fuel level gauge coupler
- 3. Rear bumper

Fig. 4-9 Fuel Pump and Level Gauge Couplers

5. Breather hose from filler neck and vapor hose from separator after removing upper protector.

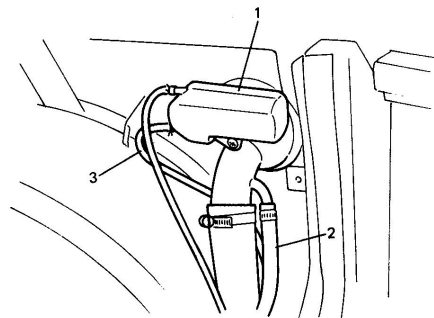

- 1. Vapor liquid separator
- 2. Breather hose
- 3. Vapor hose

Fig. 4-10 Vapor Hose and Breather Hose

5. Filler hose from fuel tank after removing lower protector.
7. Due to absence of fuel tank drain plug, drain fuel tank by pumping fuel out through fuel tank filler.
Use hand operated pump device to drain fuel tank.

CAUTION:
Never drain or store fuel in an open container due to possibility of fire or explosion.

3. Fuel filter inlet pipe from filter.

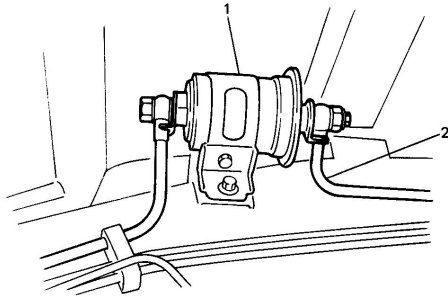

1. Fuel filter
2. Inlet pipe

Fig. 4-11

9. Detach fuel pipe clamps from chassis, and fuel filter inlet pipe from clamp.

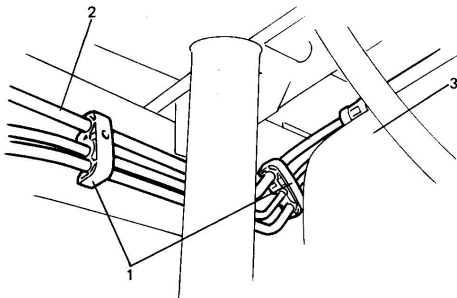

1. Clamps
2. Inlet pipe
3. Fuel tank

Fig. 4-12 Pipe Clamps

10. Fuel return hose from pipe with fuel tank and cover lowered slightly.
11. Fuel tank and cover from vehicle.

Inspect

After removing fuel tank, check hoses and pipes connected to fuel tank for leaks, loose connections, deterioration or damage. Also check fuel pump and level gauge gaskets for leaks, visually inspect fuel tank for leaks and damage. Replace any damaged or malconditioned parts.

FUEL TANK PURGING PROCEDURE

CAUTION:
This purging procedure will NOT remove all fuel vapor. Do not attempt any repair on tank where heat or flame is required, as an explosion resulting in personal injury could occur.

The following procedure is used for purging the fuel tank.

1. After removing fuel tank, remove all hoses, fuel pump and fuel level gauge from fuel tank.
2. Drain all remaining fuel from tank.
3. Move tank to flushing area.
4. Fill tank with kerosene or trichloro ethylene, and agitate vigorously and drain. Repeat this washing until inside of tank is clean. Replace tank if its inside is rusty.
5. Completely flush out remaining fluid after washing.

Install or Connect

Reverse removal procedure for installation using care for the following.

- Refer to Fig. 4-1 for piping and clamp positions.
- Clamp hoses securely.
- If pipe clamp is broken, replace it with new one.
- Use new gaskets for fuel filter inlet pipe and tighten union bolt to specified torque.
- Upon completion of installation, check fuel system for leakage according to procedure described in p. 3-4.

RECOMMENDED TORQUE SPECIFICATIONS

Fastening parts	Tightening torque		
	N-m	kg-m	lb-ft
Fuel filter union bolt	30 – 40	3.0 – 4.0	22.0 – 28.5
Blind plug of fuel filter union bolt	9 – 11	0.9 – 1.1	7.0 – 7.5
Flare nut of fuel pipe	30 – 40	3.0 – 4.0	22.0 – 28.5

SECTION 4A

ELECTRONIC FUEL INJECTION SYSTEM

CONTENTS

GENERAL DESCRIPTION	4A-3	Fuel Injection Control System	4A-21
AIR AND FUEL DELIVERY SYSTEM	4A-6	ISC Solenoid Valve Control System ...	4A-25
Fuel Pump	4A-7	Fuel Pump Control System	4A-26
Throttle Body	4A-8	Throttle Opener Control System	4A-27
Fuel Injector	4A-9	EGR Control System	4A-28
Fuel Pressure Regulator	4A-9	Electronic Spark Advance (ESA) System	4A-30
Air Valve	4A-10	DIAGNOSIS	4A-31
ISC Solenoid Valve	4A-10	Precautions in Diagnosing	
ELECTRONIC CONTROL SYSTEM ...	4A-11	Troubles	4A-31
Electronic Control Module (ECM) ...	4A-15	DIAGNOSTIC FLOW CHART	4A-33
Pressure Sensor (PS)	4A-17	Diagnostic Code Table	4A-34
Throttle Position Sensor (TPS)	4A-18	A-1 ECM Power and Ground Circuit Check	4A-35
Air Temperature Sensor (ATS)	4A-18	A-2 "CHECK ENGINE" Light Circuit Check	4A-37
Water Temperature Sensor (WTS) ...	4A-18	A-3 "CHECK ENGINE" Light Circuit Check	4A-38
Recirculated Exhaust Gas Tempera- ture Sensor (REGTS) (For California Specification Only)	4A-19	Code No. 13 Oxygen Sensor Circuit ...	4A-40
Oxygen Sensor	4A-19	Code No. 14 WTS Circuit	4A-42
Vehicle Speed Sensor (VSS)	4A-19	Code No. 15 WTS Circuit	4A-43
Crank Angle Sensor (CAS)	4A-19	Code No. 21 TPS Circuit	4A-44
Ignition Signal	4A-20	Code No. 22 TPS Circuit	4A-45
Engine Start Signal	4A-20	Code No. 23 ATS Circuit	4A-46
5th Switch (Not for California spec. Model)	4A-20	Code No. 25 ATS Circuit	4A-47
Clutch Switch	4A-20	Code No. 24 VSS Circuit	4A-48
Air-Conditioner Signal (For Vehicle with Air-Conditioner)	4A-20	Code No. 31 PS Circuit	4A-49
Battery Voltage	4A-20	Code No. 32 PS Circuit	4A-50
Diagnosis Switch Terminal	4A-21	Code No. 41 Ignition Signal Circuit ...	4A-51
Test Switch Terminal	4A-21	Code No. 42 CAS Circuit	4A-52
		Code No. 44 Idle Switch Circuit	4A-53

4A

Code No. 45 Idle Switch Circuit	4A-54	ELECTRONIC CONTROL SYSTEM	4A-90
Code No. 51 EGR System and REGTS Circuit (California Spec. Model Only) . .	4A-55	ECM (Removal and installation)	4A-90
Code No. 53 Ground Circuit (California Spec. Model Only)	4A-57	PS (Inspection)	4A-90
Code No. 54 5th Switch Circuit (Not for California Spec. Model)	4A-58	TPS (Inspection, adjustment, removal and installation)	4A-91
Code No. 71 Test Switch Circuit	4A-59	ATS (Removal, inspection and installation)	4A-94
Trouble Diagnosis	4A-60	WTS (Removal, inspection and installation)	4A-94
B-1 Fuel Injector and Its Circuit Check	4A-64	REGTS for California Spec. Model Only (Removal, inspection and installation)	4A-95
B-2 Fuel Pump Circuit Check	4A-65	Oxygen Sensor (Removal and installation)	4A-96
B-3 Fuel Pressure Check	4A-66	VSS (Inspection)	4A-96
B-4 Throttle Opener System Check . . .	4A-68	5th Switch (Not for California Spec. Model, Inspection)	4A-96
B-5 ISC Solenoid Valve Control System Check	4A-70	Clutch Switch (Inspection)	4A-97
B-6 EGR System Check	4A-72	Main Relay (Inspection)	4A-98
ECM and Its Circuit Check	4A-73	Fuel Pump Relay (Inspection)	4A-99
ON VEHICLE SERVICE	4A-77	Fuel Cut Operation (Inspection)	4A-99
General	4A-78	ISC Solenoid Valve (Inspection)	4A-99
Accelerator Cable Adjustment	4A-78	Throttle Opener System	4A-100
Idle Speed/ISC Duty Adjustment	4A-78	System Inspection	4A-100
Throttle Opener Adjustment	4A-80	Vacuum Hose Inspection	4A-100
AIR AND FUEL DELIVERY SYSTEM	4A-81	Throttle Opener Inspection	4A-100
Fuel Pressure Inspection	4A-81	VSV Inspection	4A-100
Fuel Pump (On vehicle inspection, removal, inspection and installation)	4A-82	EGR System	4A-101
Throttle Body (On vehicle inspection, air valve inspection, removal, disassembly, cleaning, assembly, installation)	4A-83	System Inspection	4A-102
Fuel Injector (On vehicle inspection, removal, inspection and installation) . .	4A-87	Vacuum Hose Inspection	4A-102
Fuel Pressure Regulator (Removal and installation)	4A-89	EGR Valve Inspection	4A-102
		EGR Modulator Inspection	4A-103
		VSV Inspection	4A-103
		SPECIAL TOOLS	4A-105
		RECOMMENDED TORQUE SPECIFICATIONS	4A-105

ABBREVIATIONS USED IN THIS SECTION

A/C	: Air-Conditioner (Air Conditioning)
ATS	: Air Temperature Sensor (Intake Air Temperature Sensor, IAT Sensor)
BVSV	: Bimetal Vacuum Switching Valve (EVAP Thermal Vacuum Valve)
CAS	: Crank Angle Sensor (Camshaft Position Sensor; CMP Sensor)
ECM	: Electronic Control Module (Engine Control Module)
EGR	: Exhaust Gas Recirculation
ESA	: Electronic Spark Advance
ISC	: Idle Speed Control (Idle Air Control, IAC)
M/T	: Manual Transmission
PCV	: Positive Crankcase Ventilation
PS	: Pressure Sensor (Manifold Absolute Pressure Sensor, MAP Sensor)
REGTS	: Recirculated Exhaust Gas Temperature Sensor (EGR Temperature Sensor)
TB	: Throttle Body
TPS	: Throttle Position Sensor (TP Sensor)
VSS	: Vehicle Speed Sensor
VSV	: Vacuum Switching Valve (Solenoid Vacuum Valve, SV Valve)
WTG	: Water Temperature Gauge (Engine Coolant Temperature Gauge, ECT Gauge)
WTS	: Water Temperature Sensor (Engine Coolant Temperature Sensor, ECT Sensor)

GENERAL DESCRIPTION

The Electronic Fuel Injection system in this vehicle supplies the combustion chambers with air/fuel mixture of optimized ratio under widely varying driving conditions.

It uses the single-point throttle body fuel injection system which injects fuel into the throttle body through one injector.

This system has 2 major sub-systems: air/fuel delivery system and electronic control system. Air/fuel delivery system includes fuel pump, throttle body, etc..

Electronic control system includes ECM, various sensors and controlled devices.

This section explains not only the system related to the electronic fuel injection but also such functions of ECM as listed below.

- EGR control system.
- Throttle opener control system.
- ESA (Electronic Spark Advance) system.

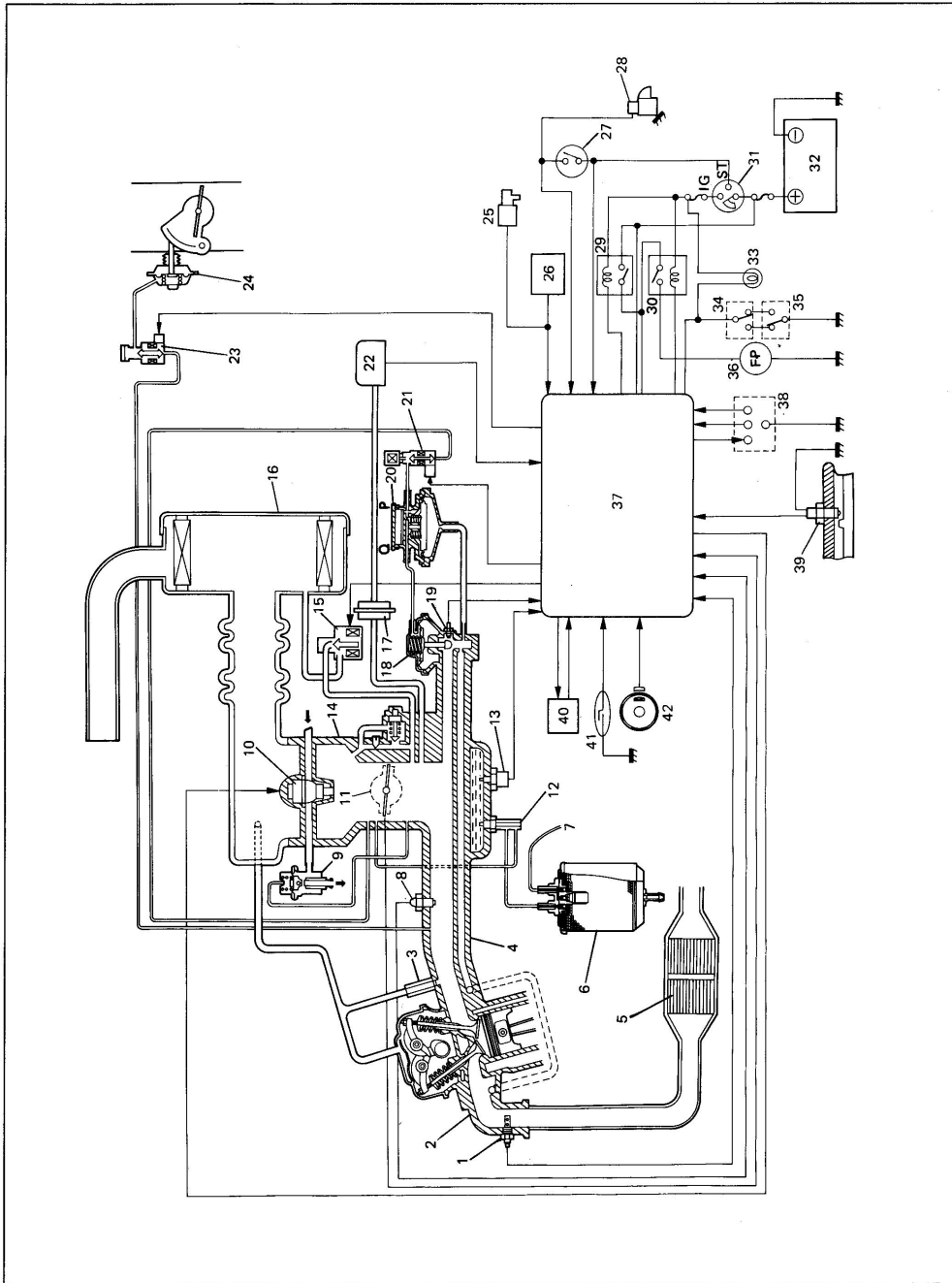

Fig. 4A-1 Electronic Fuel Injection System

4A-4

- | | | |
|----------------------------|--|--|
| 1. Oxygen sensor | 18. EGR valve | 34. Cancel switch } Federal spec. model |
| 2. Exhaust manifold | 19. REGTS
(California spec. model only) | 35. Mileage sensor } except California |
| 3. PCV valve | 20. EGR modulator | 36. Fuel pump |
| 4. Intake manifold | 21. EGR VSV (Blue) | 37. ECM |
| 5. Three way catalyst | 22. Pressure sensor | 38. Monitor coupler |
| 6. Charcoal canister | 23. Throttle opener VSV (Brown) | 39. 5th switch
(Not for California spec. model) |
| 7. To fuel tank | 24. Throttle opener | 40. Igniter |
| 8. ATS | 25. A/C VSV (if equipped) | 41. VSS |
| 9. Fuel pressure regulator | 26. A/C amplifier (if equipped) | 42. CAS |
| 10. Fuel injector | 27. Clutch switch | |
| 11. TPS | 28. Starter magnetic switch | |
| 12. BVSV | 29. Main relay | |
| 13. WTS | 30. Fuel pump relay | |
| 14. Throttle body | 31. Main switch | |
| 15. ISC solenoid valve | 32. Battery | |
| 16. Air cleaner | 33. "CHECK ENGINE" light | |
| 17. Filter | | |

AIR AND FUEL DELIVERY SYSTEM

The main components of this system are fuel tank, fuel pump, fuel filter, throttle body (including fuel injector, fuel pressure regulator and air valve), fuel feed line, fuel return line, air cleaner and ISC solenoid valve.

The fuel in the fuel tank is pumped up by the fuel pump, filtered by the fuel filter and fed under pressure to injector installed in throttle body. As the fuel pressure applied to the fuel injector (the fuel pressure in the fuel feed line) is always kept a certain amount higher than the pressure in the intake manifold by the fuel pressure regulator, the fuel is injected into the throttle body in conic dispersion when the injector opens according to the injection signal from ECM. The fuel relieved by the fuel pressure regulator returns through the fuel return line to the fuel tank.

The injected fuel is mixed with the air which has been filtered through the air cleaner in the throttle body. The air/fuel mixture is drawn through clearance between throttle valve and bore and idle bypass passage into intake manifold. Then the intake manifold distributes the air/fuel mixture to each combustion chamber.

When the engine is cold, the air is drawn through air valve bypassing the throttle valve into the intake manifold.

When ISC solenoid valve opens according to the signal from ECM, the air is drawn through hose bypassing the throttle valve into the intake manifold.

For the structure and operation of the fuel tank and filter, refer to SECTION 4 "FUEL SYSTEM".

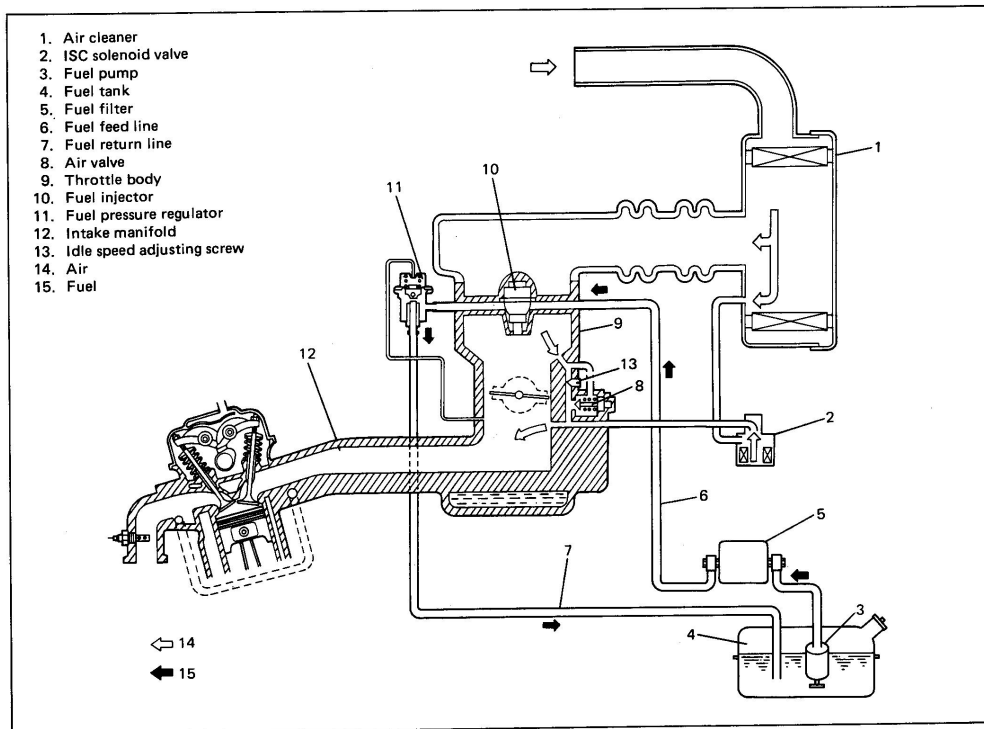

Fig. 4A-2 Air and Fuel Delivery System

Fuel Pump

The electric fuel pump located in the fuel tank consists of armature, magnet, impeller, brush, check valve, relief valve, etc.. The ECM controls its ON/OFF operation as described in item "Fuel Pump Control System".

Operation

When power is supplied to the fuel pump, the motor in the pump runs and so does the impeller. This causes a pressure difference to occur between both sides of the impeller as there are many grooves around it. Then the fuel is drawn through the inlet port, and with its pressure increased it is discharged through the outlet port. The fuel pump also has a relief valve to prevent excessive rise of the discharge pressure and a check valve to keep some pressure in the fuel feed line even when the fuel pump is stopped.

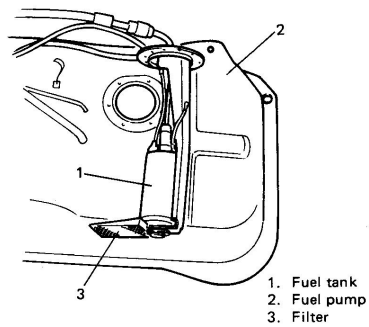

Fig. 4A-3 Fuel Pump Mounting

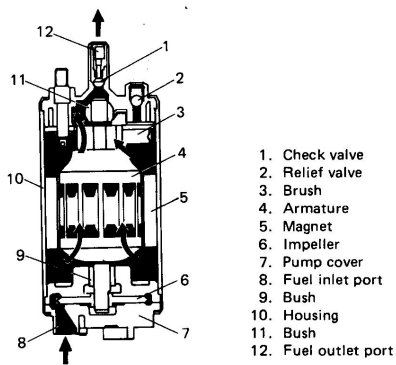

Fig. 4A-4 Fuel Pump Cross-Section

Throttle Body

The throttle body consists of the main bore, air bypass passage, fuel passage, vacuum passage (for EGR system and canister purge system) and the following parts.

- Injector which injects fuel according to the signal from ECM
- Fuel pressure regulator which maintains the fuel pressure to the injector a certain amount higher than the pressure in the intake manifold
- Throttle valve which is interlocked with the accelerator pedal and controls the amount of the air fuel mixture drawn into the combustion chamber
- Throttle opener which controls the throttle valve opening so that it is a little wider when the engine is starting than when the engine is idling
- TPS which detects the throttle valve opening and sends a signal to ECM
- Air valve which supplies the bypass air when the engine is cold
- Idle speed adjusting screw which controls the amount of bypass air to adjust engine idle speed

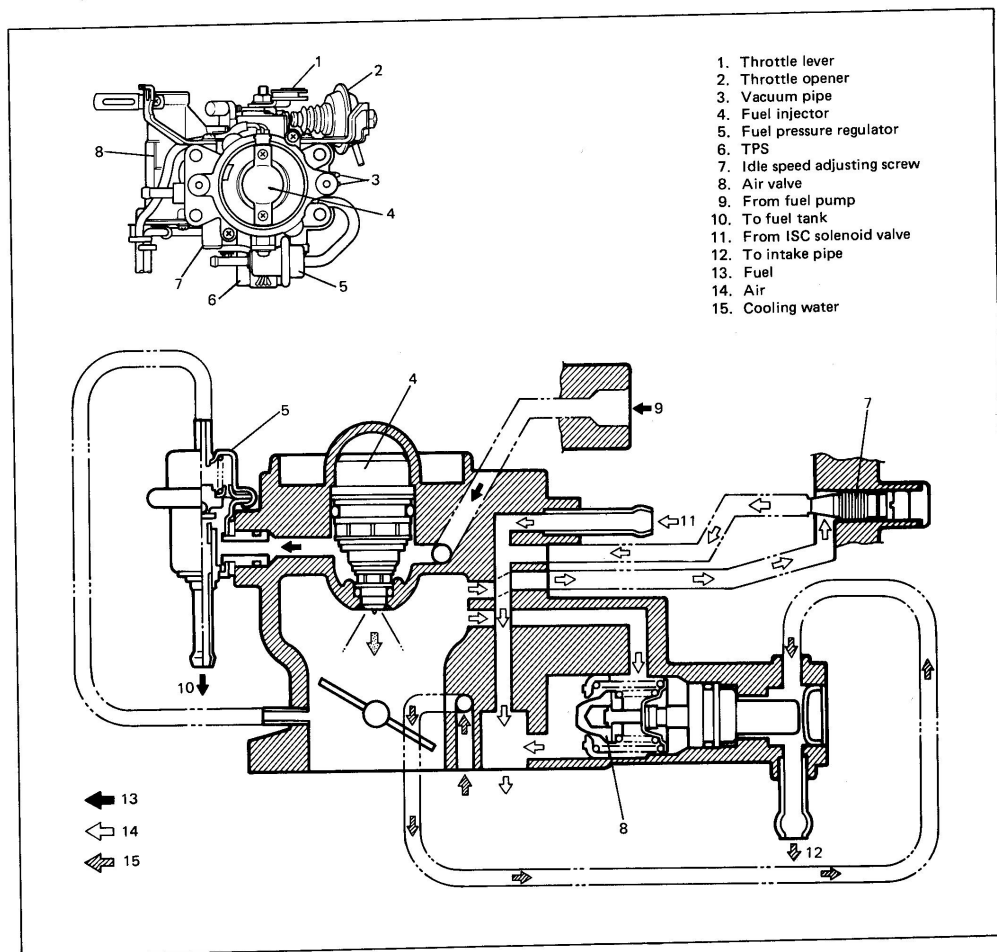

Fig. 4A-5 Throttle Body Cross-Section

4A-8

Fuel Injector

It is an electromagnetic type injection nozzle which injects fuel in the throttle body bore according to the signal from ECM.

Operation

When the solenoid coil of the injector is energized by ECM, it becomes an electromagnet and attracts the plunger. At the same time, the needle valve which is incorporated with the plunger opens and the injector which is under the fuel pressure injects fuel in conic dispersion. As the lift stroke of the needle valve of the injector is set constant, the amount of fuel injected at one time is determined by the length of time during which the solenoid coil is energized (injection time).

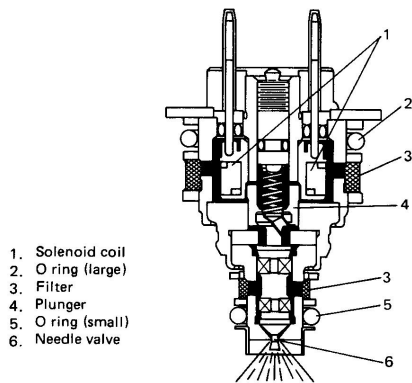

Fig. 4A-6 Injector Cross-Section

Fuel Pressure Regulator

The fuel pressure regulator keeps the fuel pressure applied to the injector 2.65 kg/cm^2 (265 kPa) higher than that in the intake manifold at all times.

The pressure applied to the chamber "A" of fuel pressure regulator is intake manifold pressure and that to the chamber "B" is fuel pressure.

When the fuel pressure rises more than 2.65 kg/cm^2 (265 kPa) higher than the intake manifold pressure, the fuel pushes the valve in the regulator open and excess fuel returns to the fuel tank via the return pipe.

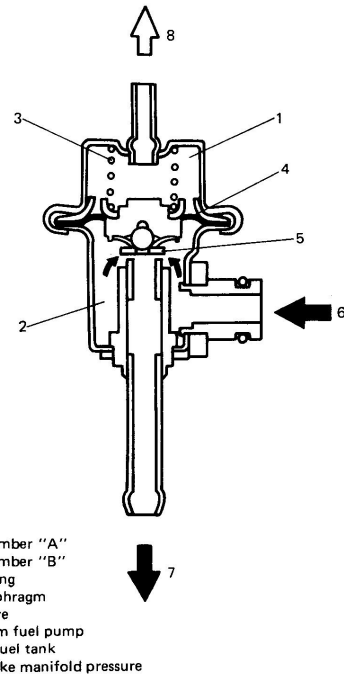

Fig. 4A-7 Pressure Regulator Cross-Section

Air Valve

The air valve consists of thermo-wax, springs and valve.

When the engine is cold, it sends the air from the air cleaner to the intake manifold without letting it pass through the throttle valve to increase the engine speed, and thus the engine is warmed up.

Operation

When the engine is cold (or engine cooling water is lower than about 60° C (140° F)), the thermo-wax contracts.

In this state, the valve is pushed to the left by the spring force and opens the air passage, allowing the air from the air cleaner to be drawn into the intake manifold. Thus the amount of intake air increases even when the throttle valve is at the idle position and the engine speed rises to the fast idle state which is higher than the idle speed.

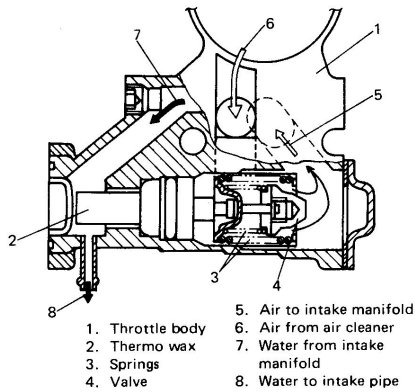

Fig. 4A-8 Air Valve Open

As the engine is warmed up, the thermo-wax expands gradually, then the piston is pushed to move the valve to the right gradually, and the amount of air passing through the air passage decreases and so does the engine speed. When the engine cooling water temperature reaches about 60° C (140° F), the valve is fully closed and the engine speed is back to the normal idle speed.

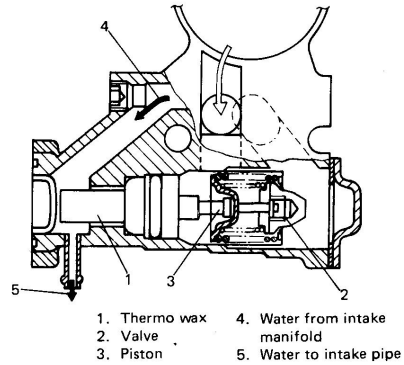

Fig. 4A-9 Air Valve Close

ISC (Idle Speed Control) Solenoid Valve

The ISC solenoid valve opens and closes air by-pass passage according to the signal from ECM. When it opens, the air is supplied to the intake manifold.

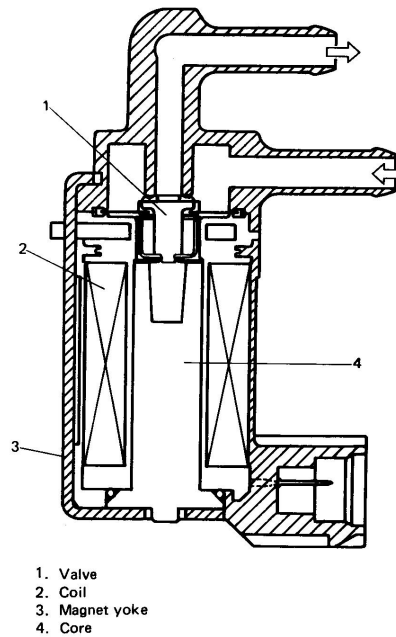

Fig. 4A-10 ISC Solenoid Valve Cross-Section

4A-10

ELECTRONIC CONTROL SYSTEM

The electronic control system consists of 1) various sensors which detect the state of engine and driving conditions, 2) ECM which controls various devices according to the signals from the sensors and 3) various controlled devices.

Functionally, it is divided into six sub systems:

- Fuel injection control system
- ISC solenoid valve control system
- Fuel pump control system
- Throttle opener control system
- EGR control system
- ESA control system

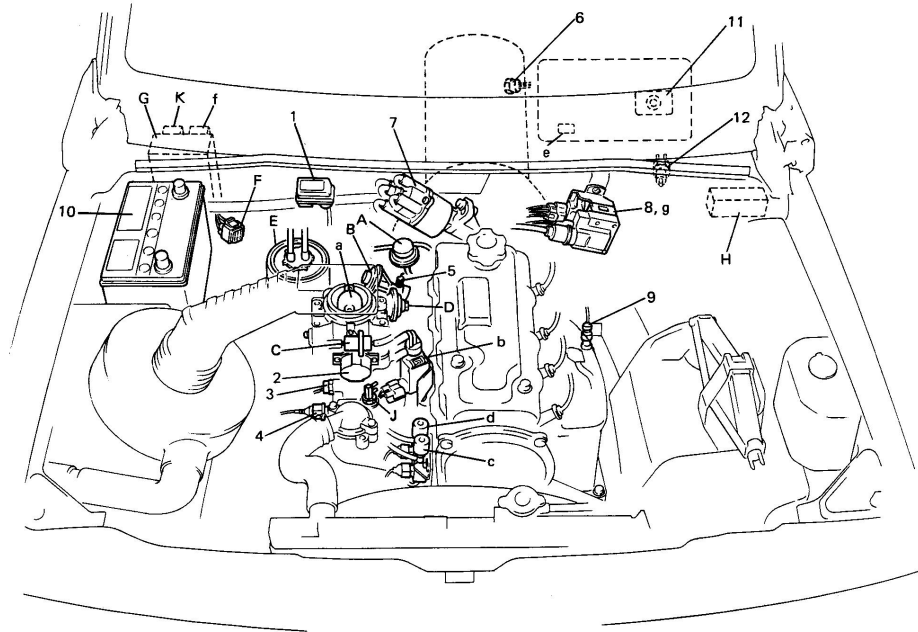

INFORMATION SENSORS

1. Pressure sensor
2. TPS
3. ATS
4. WTS
5. REGTS
(California spec. model only)
6. 5th switch
(Not for California spec. model)
7. CAS (in distributor)
8. Igniter (Power unit)
9. Oxygen sensor
10. Battery
11. VSS
12. Clutch switch

CONTROLLED DEVICES

- a : Injector
- b : ISC solenoid valve
- c : Throttle opener
VSV (Brown)
- d : EGR VSV (Blue)
- e : "CHECK ENGINE" light
- f : Fuel pump relay
- g : Igniter (Power unit)

OTHERS

- A : EGR modulator
- B : EGR valve
- C : Fuel pressure regulator
- D : Throttle opener
- E : Canister
- F : Monitor coupler
- G : ECM
- H : Fuse box (Diagnosis switch terminal)
- J : BVS
- K : Main relay

Fig. 4A-11 Component Parts Location

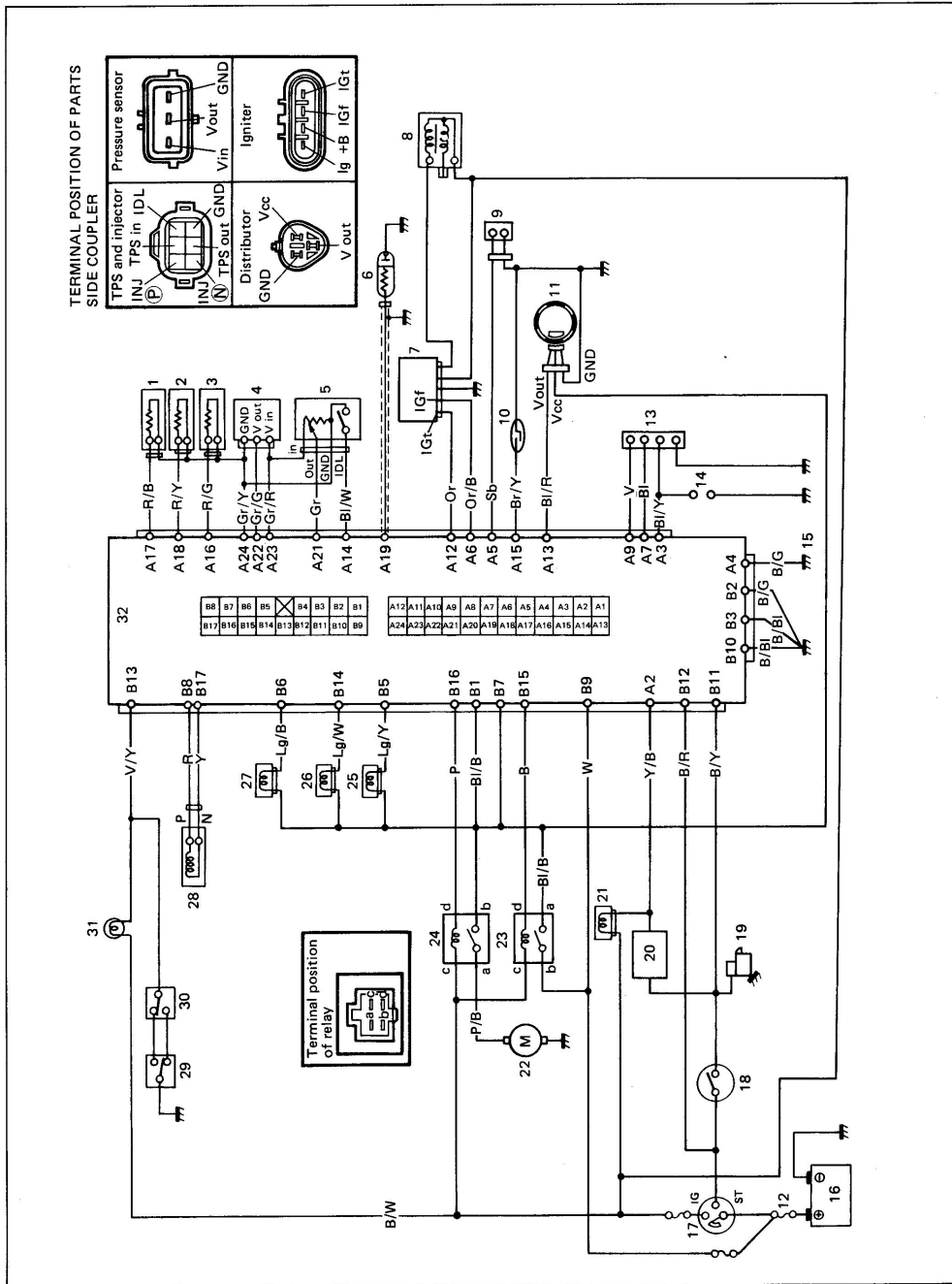

Fig. 4A-12 System Wiring Diagram

4A-12

	Wire color
1. ATS	B/BI Black/Blue
2. WTS	B/G Black/Green
3. REGTS (California spec. model only)	B/Y Black/Yellow
4. Pressure sensor	BI Blue
5. TPS	BI/B Blue/Black
6. Oxygen sensor	BI/R Blue/Red
7. Igniter (Power unit)	BI/W Blue/White
8. Ignition coil	BI/Y Blue/Yellow
9. 5th switch (Not for California spec. model)	BI/O Blue/Orange
10. VSS	Br/B Brown/Black
11. CAS (in distributor)	Br/Y Brown/Yellow
12. Fusible link	Gr Gray
13. Monitor coupler	Gr/G Gray/Green
14. Diag. switch terminal (in fuse box)	Gr/R Gray/Red
15. Ground (California spec. model only)	Gr/Y Gray/Yellow
16. Battery	Lg Lightgreen
17. Main switch	Lg/B Lightgreen/Black
18. Clutch switch	Lg/W Lightgreen/White
19. Starter magnetic switch	Lg/Y Lightgreen/Yellow
20. A/C amplifier (if equipped)	P Pink
21. A/C VSV (if equipped)	R Red
22. Fuel pump	R/B Red/Black
23. Main relay	R/G Red/Green
24. Fuel pump relay	R/Y Red/Yellow
25. EGR VSV	Sb Skyblue
26. Throttle opener VSV	V Violet
27. ISC solenoid valve	V/Y Violet/Yellow
28. Fuel injector	W White
29. Mileage sensor } Federal spec. model except	Y Yellow
30. Cancel switch } California and Canada	Y/B Yellow/Black
31. "CHECK ENGINE" light	R/BI Red/Blue
32. ECM	

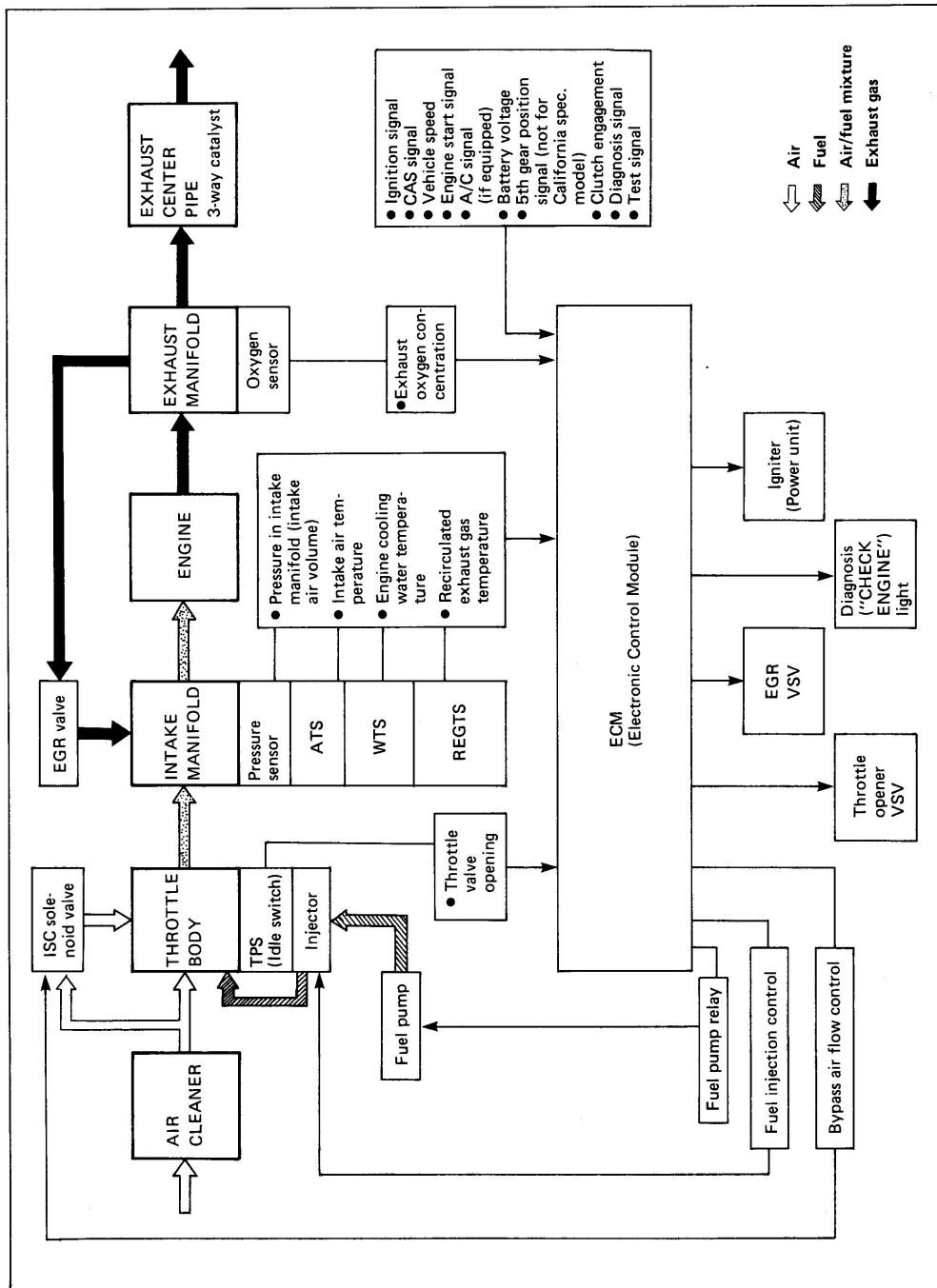

Fig. 4A-13 System Schematic

4A-14

Electronic Control Module (ECM)

ECM is installed under the glove box of the instrument panel.

ECM is a precision unit consisting of one chip microcomputer, A/D (Analog/Digital) converter, I/O (Input/Output) unit and etc..

It is an essential part of the electronic control system, for its functions include not only such a major function as to control fuel injector, ISC solenoid valve, throttle opener VSV, etc. but also self-diagnosis function, fail safe function and back-up function as described in the following section.

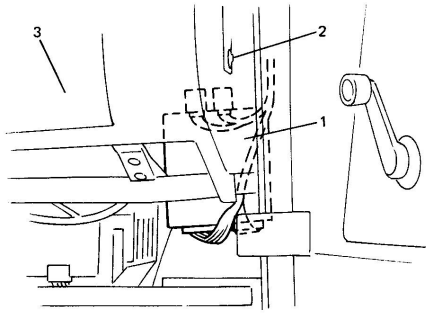

1. ECM
2. Instrument main panel
3. Glove box

Fig. 4A-14 ECM Location

Self-diagnosis function

When any of such troubles as listed below occurs in Electronic Fuel Injection system, ECM activates "CHECK ENGINE" light while engine is running to warn the driver of occurrence of such trouble and stores the data on defective area (where trouble occurred) in its back-up memory. (The memory is kept as it is even if the trouble was only temporary and disappeared immediately. And it is not erased unless the power to ECM is shut off for 20 seconds or longer.) ECM also indicated defective area in memory by means of flashing of "CHECK ENGINE" light at the time of inspection (i.e. when diagnosis switch terminal is grounded and ignition switch is turned ON).

- When ECM received a defect informing signal from any one of following sensors and circuits or no signal whatever
 - * Oxygen sensor
 - * ATS
 - * Pressure sensor
 - * WTS
 - * TPS
 - * VSS
 - * Idle switch
 - * CAS
 - * 5th switch (Not for California spec. model)
 - * Ignition circuit
 - * Ground circuit (California spec. model only)
- When a trouble exists in EGR system (or recirculated exhaust gas temperature sensor is defective) . . . For California spec. model only
- When CPU (Central Processing Unit) of ECM fails to operate

NOTE:

- Even when a trouble occurs in CAS, 5th switch circuit or idle switch circuit (circuit open), ECM does not indicate it (or activate "CHECK ENGINE" light) while engine is running. And when that troubled circuit regains good condition, the memory of defective area will be erased automatically even if the power circuit to ECM is not opened as described above.

- Only ignition circuit trouble (code No. 41 among the above areas is not stored in back-up memory of ECM. (In other words, even if ECM has detected a trouble in ignition circuit, once ignition switch is turned OFF, code No. 41 will not be indicated even when diagnosis switch terminal is grounded and ignition switch is turned ON.). Therefore, to check diagnostic code when engine fails to start, crank engine and then ground diagnosis switch terminal with ignition switch ON.

[“CHECK ENGINE” light]

“CHECK ENGINE” light is located among the instrument cluster. It indicates each result of diagnosis done by ECM’s self-diagnosis function. It also lights under the conditions as described below regardless of Electronic Fuel Injection system condition.

- When ignition switch is turned ON, engine is at a stop (When engine speed is lower than 500 r/min.) and diagnosis switch terminal is ungrounded, “CHECK ENGINE” light turns ON for the purpose of light and its circuit check but turns OFF once engine is started (When engine speed is higher than 500 r/min.) as far as Electronic Fuel Injection system is in good condition.
- Only federal spec. model except California and Canada has mileage sensor and cancel switch in its “CHECK ENGINE” light circuit. When mileage reaches 50,000, 80,000 and 100,000 miles respectively (i.e. mileage sensor turns ON) “CHECK ENGINE” light turns ON even while engine is running. This is to warn the driver that it is time for periodical inspection. In this case, turn OFF “CHECK ENGINE” light with its cancel switch upon completion of inspection.

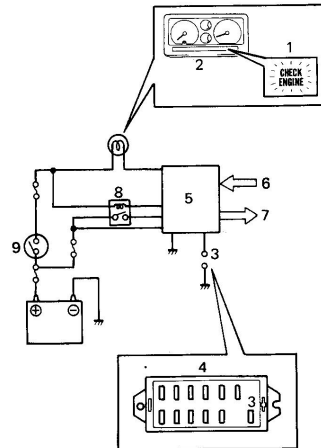

- | | |
|------------------------------|-----------------------|
| 1. “CHECK ENGINE” light | 5. ECM |
| 2. Cluster | 6. Sensed information |
| 3. Diagnosis switch terminal | 7. Output |
| 4. Fuse box | 8. Main relay |
| | 9. Ignition switch |

Fig. 4A-15 “CHECK ENGINE” Light Circuit for California and Canada spec. Model

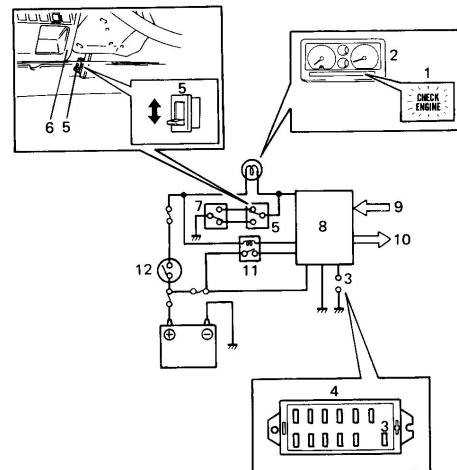

- | | |
|------------------------------|-----------------------|
| 1. “CHECK ENGINE” light | 8. ECM |
| 2. Cluster | 9. Sensed information |
| 3. Diagnosis switch terminal | 10. Output |
| 4. Fuse box | 11. Main relay |
| 5. Cancel switch | 12. Ignition switch |
| 6. Instrument panel | |
| 7. Mileage sensor | |

Fig. 4A-16 “CHECK ENGINE” Light Circuit for Federal Spec. Model Except California and Canada

Fail-safe function

When a failure occurs in any of the sensors listed below and their circuits, a signal indicating such failure is fed to ECM, which judges that signal as such.

Even then, however, control over the injector, ISC solenoid valve and others is maintained on the basis of the standard signals prestored in the memory of ECM while ignoring that failure signal. This function is called "fail-safe function". Thus, with this function, a certain level of engine performance is available even when some failure occurs in these sensors or their circuits and disability in running is avoided.

- WTS
- TPS
- ATS
- Pressure sensor

Back-up function

Even when CPU in ECM fails to operate properly, the back-up circuit in ECM controls operation of the injector on the basis of the signals from pressure sensor so as to least impair driving performance.

Pressure (Intake manifold absolute pressure) Sensor (PS)

This sensor senses pressure change in the intake manifold and converts it into voltage change. It consists of a semi-conductor type pressure converting element which converts a pressure change into an electrical change and an electronic circuit which amplifies and corrects the electric change. The ECM sends a 5-volt reference voltage to the pressure sensor. As the manifold pressure changes, the electrical resistance of the sensor also changes. By monitoring the sensor output voltage, ECM knows the manifold pressure (intake air volume).

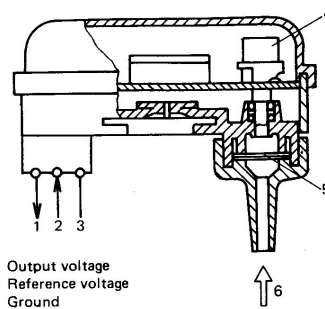

1. Output voltage
2. Reference voltage
3. Ground
4. Semi-conductor type pressure converting element
5. Filter
6. Intake manifold pressure (Vacuum)

Fig. 4A-17 Pressure Sensor

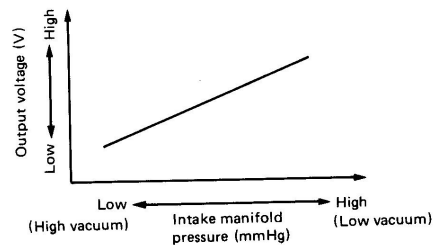

Fig. 4A-18 Output Characteristic

ECM uses the voltage signal from the pressure sensor as one of the signals to control fuel injection time, ISC solenoid valve operation, EGR VSV operation and ignition timing.

Throttle Position Sensor (TPS)

The throttle position sensor consisting of a contact point (idle switch) and a potentiometer is connected to the throttle valve shaft on the throttle body, and detects the throttle valve opening.

The throttle opening in the idle state is detected by means of the contact point which turns ON in that state.

But beyond that the full opening is detected by the potentiometer as follows.

A 5-volt reference voltage is applied to the sensor from ECM and as its brush moves over the print resistance according to the throttle valve opening, the output voltage varies accordingly.

By monitoring the sensor output voltage, ECM detects the throttle valve opening and its change.

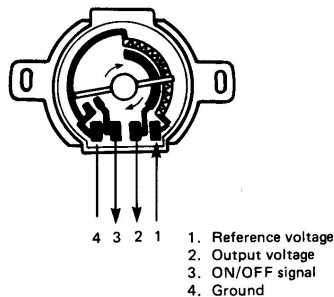

Fig. 4A-19 Throttle Position Sensor

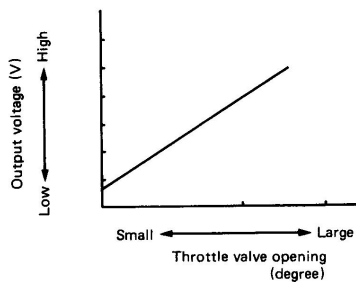

Fig. 4A-20 Output Characteristic

Air Temperature Sensor (ATS)

Located at the side of intake manifold, this sensor constantly measures the temperature of the air entering there and converts a change in the air temperature into that in resistance through its thermister. That is, as air temperature lowers, resistance increases and as it rises, resistance decreases. As air density of the intake air varies with variation in temperature, ECM, by monitoring the resistance, adjusts the amount of fuel injection according to the air temperature.

Water Temperature Sensor (WTS)

Located at the side of intake manifold, this sensor measures the temperature of the engine cooling water and converts its change into that in resistance through the thermister like the air temperature sensor.

That is, as cooling water temperature lowers, resistance increases and as it rises, resistance decreases.

By monitoring the resistance of the water temperature sensor, ECM detects the engine cooling water temperature and that affects most systems under the control of ECM.

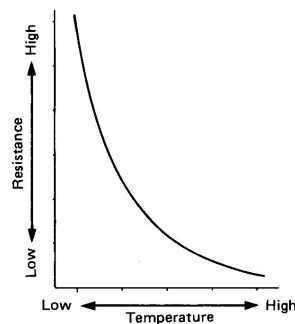

Fig. 4A-21 Air/Water Temperature Sensor Characteristic

Recirculated Exhaust Gas Temperature Sensor (REGTS) (For California spec. model only)

This sensor is located at the EGR valve. Like the air and water temperature sensors described previously, it measures the temperature of the gas which was recirculated through the EGR valve and converts a change in the exhaust gas temperature into that in resistance to send it to ECM. ECM uses it for diagnosing a trouble in the EGR system.

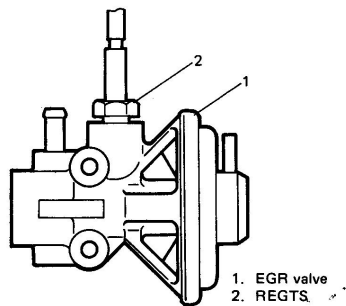

Fig. 4A-22 REGTS

Oxygen Sensor

The oxygen sensor is located on the exhaust manifold to detect the concentration of oxygen in the exhaust gases.

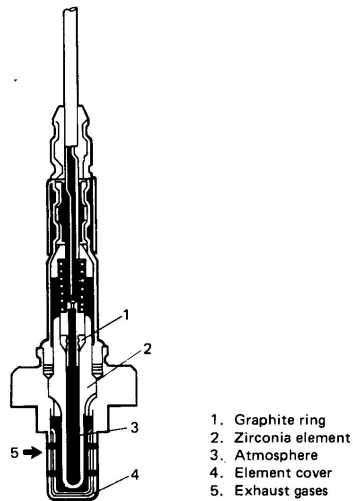

Fig. 4A-23 Oxygen Sensor

Vehicle Speed Sensor (VSS)

The VSS consisting of the lead switch and magnet is built in the speedometer. As the magnet turns with the speedometer cable, its magnetic force causes the lead switch to turn ON and OFF. Such ON/OFF frequency increases or decreases in proportion with the vehicle speed and is sent to ECM as pulse signals. ECM uses it as one of the signals to control the ISC solenoid valve.

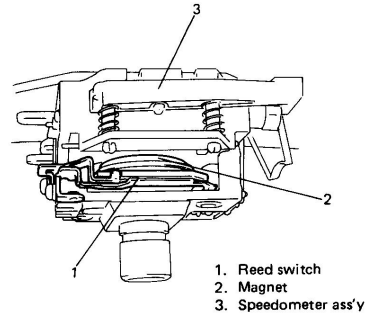

Fig. 4A-24 VSS

Crank Angle Sensor (CAS)

The crank angle sensor located in the distributor consists of the signal generator (hall element and magnet) and signal rotor.

As the signal rotor turns, it causes the magnetic flux from the magnet to be applied to the hall element intermittently. The hall element generates the voltage in proportion with the magnetic flux as shown below. This voltage is wave-shaped into the pulse signal (sensor signal) by the comparator.

This pulse signal (4 pulses/revolution) is sent to ECM where it is used to calculate the engine speed and also as one of the signals to control fuel injector and ignition timing.

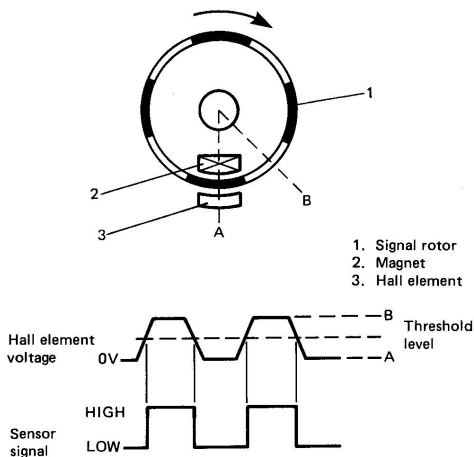

Fig. 4A-25 CAS

Ignition Signal (ignition fail safe signal)

This signal is sent from the igniter. ECM uses it as one of the signals for controlling fuel injector.

Engine Start Signal

This signal is sent from the engine starter circuit. Receiving it, ECM judges whether the engine is cranking or not and uses it as one of the signals to control fuel injection timing, injection time, ISC solenoid valve operation and throttle opener VSV operation.

5th Switch (Not for California spec. model)

Located on the transmission, it turns ON when the gear shift lever is shifted to the 5th gear position and OFF when it is at any other position. The ON/OFF signal from this switch is one of the signals that ECM uses to control EGR VSV.

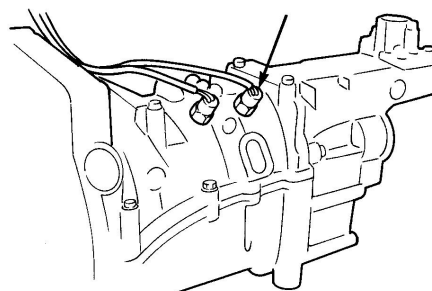

Fig. 4A-26 5th Switch

Clutch Switch

Located above the clutch pedal, it turns ON when clutch pedal is depressed and OFF when released. ECM uses it as one of the signals for controlling fuel injector.

Air-Conditioner Signal (For vehicle with A/C)

This signal is sent from the air-conditioner circuit. ECM detects whether the air-conditioner is operating or not through the signal and uses it as one of the signals for controlling ISC solenoid valve operation.

Battery Voltage

The fuel injector is driven by its solenoid coil based upon the ECM output signal. There is some delay called as "Ineffective injection time", which doesn't provide fuel, between ECM signal and valve action. As the ineffective injection time depends on the battery voltage, ECM takes voltage information to compensate it in fuel injection time.

Diagnosis Switch Terminal

There are two diagnosis switch terminals; one included in the fuse box and the other in the monitor coupler in the engine room. When either diagnosis switch terminal is grounded, a diagnosis signal is fed to ECM which then outputs self-diagnosis code and at the same time outputs ISC duty through duty check terminal.

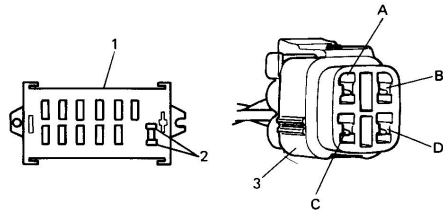

- | | |
|------------------------------|------------------------------|
| 1. Fuse box | A: Duty check terminal |
| 2. Diagnosis switch terminal | B: Diagnosis switch terminal |
| 3. Monitor coupler | C: Ground terminal |
| | D: Test switch terminal |

Fig. 4A-27 Diagnosis and Test Switch Terminals

Test Switch Terminal

The test switch terminal is included in the monitor coupler. When this terminal is grounded, ECM sets the ignition timing to the specification and turn "CHECK ENGINE" light ON even when engine is running.

When both test switch terminal and diagnosis switch terminal are grounded, ECM outputs A/F duty through the duty check terminal and "CHECK ENGINE" light indicates diagnostic code No. 71, but it is nothing abnormal.

FUEL INJECTION CONTROL SYSTEM

In this system, ECM controls the time (amount) and timing of the fuel injection from the fuel injector into the throttle body according to the signals from the various sensors so that suitable air/fuel mixture is supplied to the engine in each driving condition.

Injection Timing

- At start
Fuel is injected at a certain cycle starting immediately after the initial CAS signal is inputted.

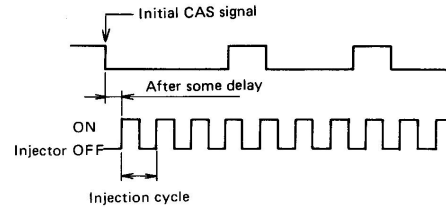

Fig. 4A-28 Injection Timing at Start

- In normal driving (Standard injection timing)
Fuel is injected at every ignition signal (ignition fail safe signal) synchronously.

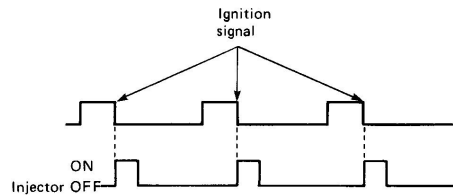

Fig. 4A-28-1 Injection Timing in Normal Driving

- When accelerating (Additional injection timing)
Fuel is injected in addition to the above standard injection timing whenever the throttle valve opening exceeds the specified opening.

Injection Time (amount of injection)

The factors to determine the injection time are the basic injection time which is calculated on the basis of the engine speed and the intake manifold pressure (amount of the intake air) and various compensations which are determined according to the signals from various sensors that detect the state of the engine and driving conditions.

NOTE:

The amount of fuel drawn into the engine is determined by the injection frequency as well as injection time.

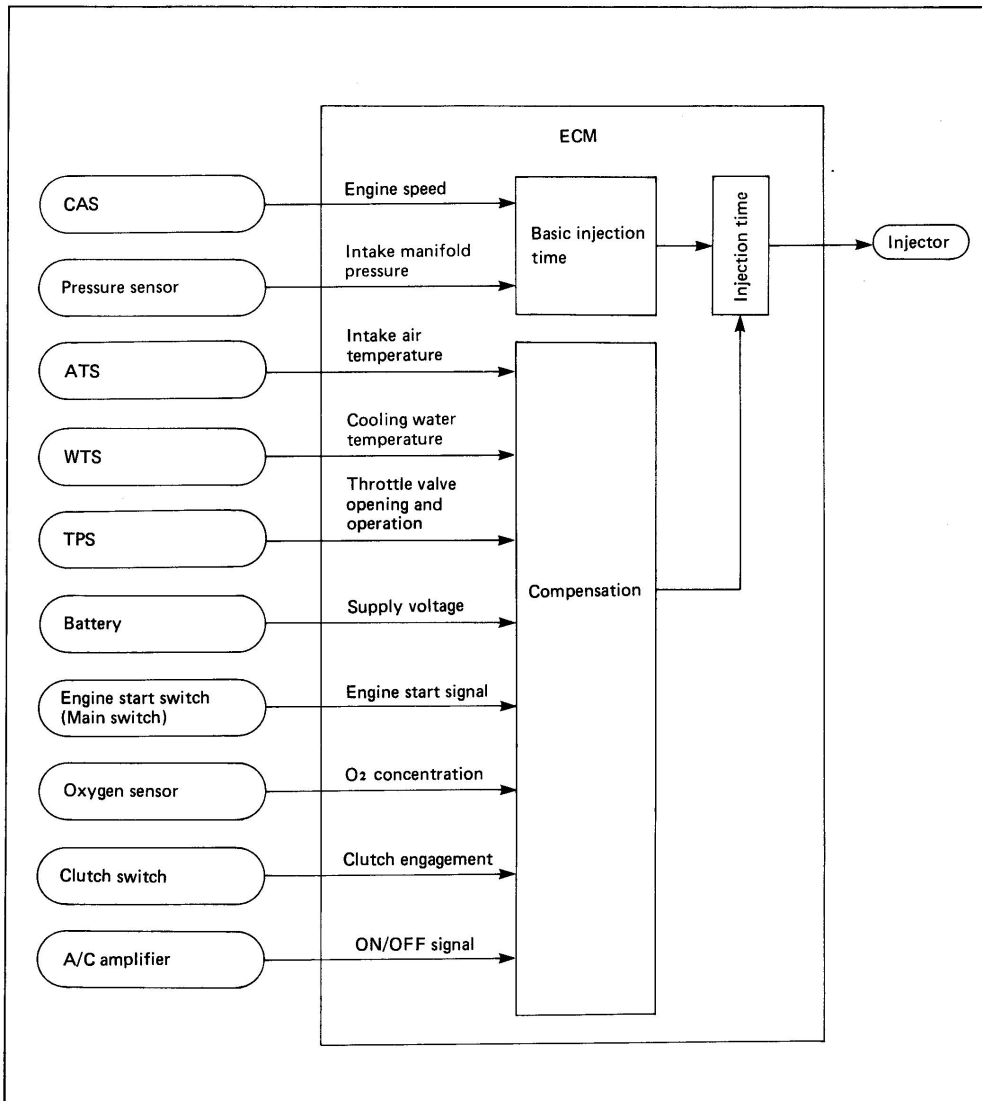

Fig. 4A-28-2 Parameter Diagram

Intake air temperature compensation

As the intake air volume varies with the temperature, it is compensated for its temperature.

Enriching compensation while warming up

When the engine is cold, enriching compensation is made to ensure good driveability till the engine cooling water temperature reaches the specified level. The amount to enrich the air/fuel mixture is decreased as the temperature rises.

Enriching compensation after engine start

For a certain time after the engine is started, air/fuel mixture enriching compensation is made so as to stabilize the engine speed. As the amount of compensation depends on the engine cooling water temperature, it is the largest immediately after the engine start and after that, it reduces gradually.

Enriching compensation while loaded high

Enriching compensation is made to make the air/fuel mixture ratio richer than the theoretical air/fuel mixture ratio to ensure good driveability under highly loaded driving condition.

Enriching compensation when accelerating

To attain smooth acceleration, enriching compensation is provided for a certain time according to each accelerating condition, which is obtained through operation using the signal from the pressure sensor (representing variation of pressure in the intake manifold).

Leaning compensation when decelerating

To obtain a proper air/fuel mixture ratio during moderate deceleration, compensation is made for a certain time so that the air/fuel mixture leans out to a proper ratio for each decelerating condition, which is obtained through operation using the signal from the throttle position sensor (representing variation of throttle valve opening).

Battery voltage compensation

A power voltage drop delays the mechanical operation of the injector. Then the actual injection time becomes shorter for the time that electricity is supplied to the injector. To compensate this, the electricity supply time is made longer when the voltage is lower.

Base air/fuel ratio compensation

The air/fuel ratio may vary due to such factors as variation in each engine itself and aging. To compensate such variation, feed back compensation is used and base air/fuel mixture ratio is adjusted to a proper level.

Fuel cut

When decelerating quickly, the fuel supply is cut or decreased to prevent unburned gas from being emitted by making the injector operating time as ineffective injection time.

Also, when the engine speed exceeds 6,800 r/min, the fuel supply is cut to protect the engine by making the injector operating time as ineffective injection time. The normal injection is restored when the engine speed is 6,500 r/min or lower.

Fuel feed back compensation (Air/fuel ratio compensation)

It is necessary to keep the air/fuel mixture close to the theoretical air/fuel ratio (14.7) to obtain efficient performance of the 3-way catalyst and high clarification rate of CO, HC and NO_x in the exhaust gas. For that purpose, ECM operates as follows. It first compares the signal from the oxygen sensor with a specified reference voltage and if the signal is higher, it detects that the air/fuel ratio is richer than the theoretical air/fuel ratio and reduces fuel. On the other hand, if the signal is lower, it detects that the air/fuel ratio is leaner and increases fuel. By repeating these operations, it adjusts the air/fuel ratio closer to the theoretical air/fuel ratio.

- 1) When oxygen concentration in the exhaust gas is low, that is, when the air/fuel ratio is smaller than the theoretical air/fuel ratio (fuel is richer), electromotive force of the oxygen sensor increases and a rich signal is sent to ECM.
- 2) Upon receipt of the rich signal, ECM decreases the amount of fuel injection, which causes oxygen concentration in the exhaust gas to increase and electromotive force of the oxygen sensor to decrease. Then a lean signal is sent to ECM.
- 3) As ECM increases the amount of fuel injection according to the lean signal, oxygen concentration in the exhaust gas decreases and the situation is back to above 1).

This control process, however, will not take place under any of the following conditions.

- At engine start and when fuel injection is increased after engine start
- When engine cooling water temperature is low
- When highly loaded and fuel injection is increased
- At fuel cut
- When oxygen sensor is cold

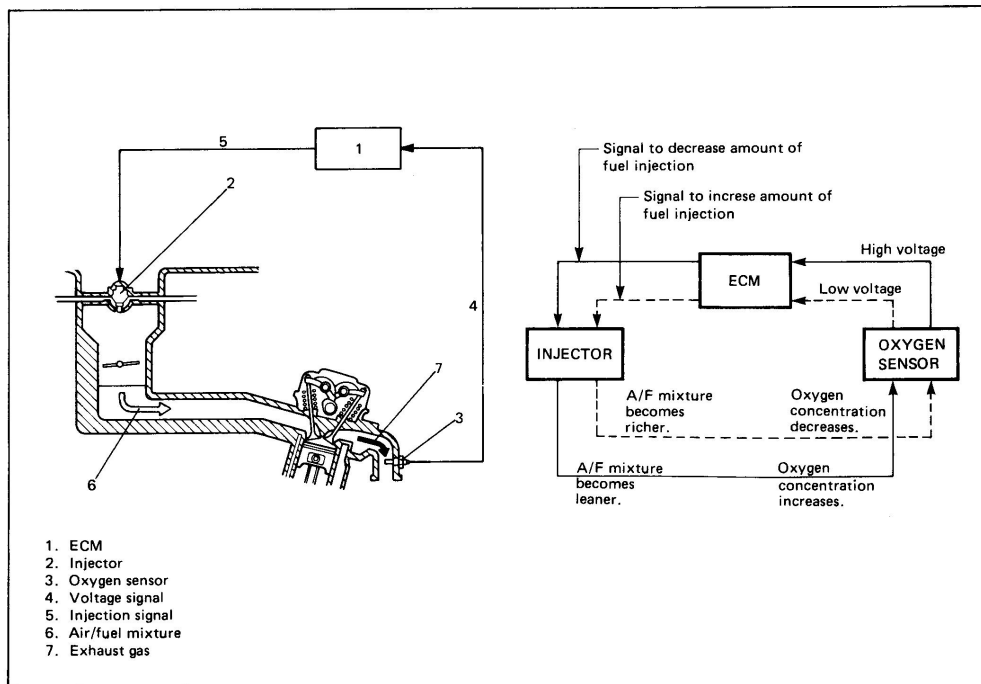

Fig. 4A-29 Fuel Feed Back Compensation

ISC SOLENOID VALVE CONTROL SYSTEM

This system controls the bypass air flow by means of ECM and ISC solenoid valve for the following three purposes.

- To keep the engine idle speed as specified at all times
The engine idle speed can vary due to following reasons.
 - * Load applied to engine (when electric load is applied, air-conditioner is turned ON, etc.)
 - * Variation in atmospheric pressure
 - * Change in engine itself with passage of time
 - * Other factors causing idle speed to change
- To improve starting performance of engine
- To compensate air/fuel mixture ratio when decelerating (Dash-pot effect)

Operation

ISC solenoid valve opens the bypass air passage when it is turned ON by ECM and closes it when turned OFF.

ECM detects the engine condition by using signals from various sensors and switches and while repeating ON and OFF cycle of ISC solenoid valve at a certain rate (12.5 times a second), it controls bypass air flow by increasing and decreasing its ON time within a cycle.

While the engine is cranking, ECM keeps ISC solenoid valve ON (maximum ON time rate within one cycle) so as to obtain better start of the engine.

When the accelerator pedal is depressed while the engine is running (the idle switch is OFF and the throttle valve is at other than idle position), ECM sets the ON time of the ISC solenoid valve (rate of ON time within one cycle) so that it is determined by the engine conditions and keeps it. When decelerating, on the other hand, ECM reduces the valve ON time gradually (i.e., the bypass air flow is reduced gradually) to obtain dash-pot effect.

When the vehicle is at a stop, the throttle valve is at the idle position and the engine is running, ECM controls the bypass air flow by increasing or decreasing ON time of ISC solenoid valve so that the engine speed is kept at a specified idle speed.

With an A/C equipped vehicle, when the A/C is ON, a certain amount of the bypass air is supplied by the A/C VSV independently of this system. The bypass air supplied by this system is used for fine control to keep the idle speed as specified.

	A/C OFF	A/C ON
Engine idle speed specification	800 ± 50 r/min.	1,000 ± 50 r/min.

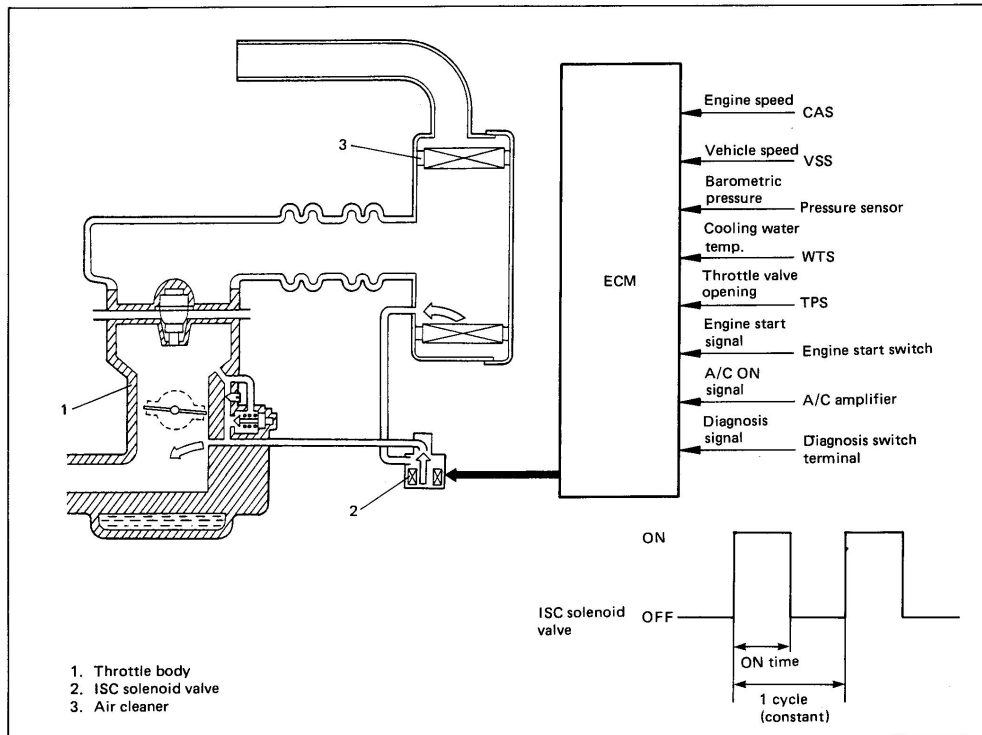

Fig. 4A-30 ISC Solenoid Valve Control System

FUEL PUMP CONTROL SYSTEM

ECM controls ON/OFF operation of the fuel pump by turning it ON via the fuel pump relay under any of the following condition.

- For 3 seconds after ignition switch ON.
- While cranking engine (while engine start signal is inputted to ECM).
- While CAS signal is inputted to ECM.

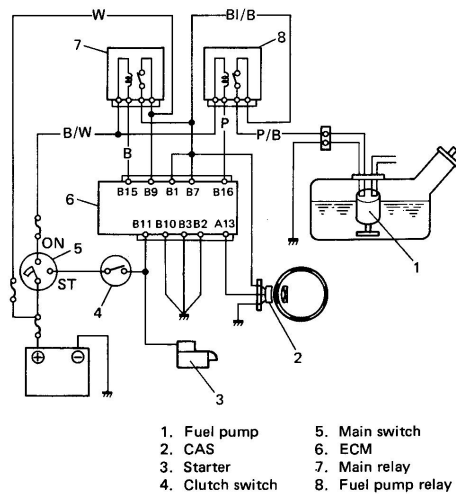

Fig. 4A-31 Fuel Pump Circuit

THROTTLE OPENER CONTROL SYSTEM

In this system, the throttle valve is opened a little wider than the idle position to improve the engine performance at its start.

The throttle opener is controlled by VSV (Vacuum Switching Valve) which opens and closes the vacuum passage to the throttle opener.

ECM controls VSV according to the engine speed, starter signal and signal from the WTS and turns ON the electric circuit of VSV when;

- the engine is cranking
- the engine speed is less than 4,000 r/min, for 0 to some ten seconds after the engine start (duration time depends on the cooling water temperature, e.g. shorter for higher cooling water temperature.)

In either of the above conditions, VSV opens between the filter and passage "A" and closes between passages "A" and "B". In this state, like when the engine is at a stop, the chamber "C" of the throttle opener is under the atmospheric pressure. It means that the spring force pushes the rod to open the throttle valve.

Once the engine starts to run, ECM turns OFF the electric circuit of VSV which then opens between passages "A" and "B" and closes between the filter and passage "A". Consequently, the vacuum in the intake manifold is applied to the chamber "C" of the throttle opener and the diaphragm and rod are pulled. In this way, the throttle valve moves back to its idle position.

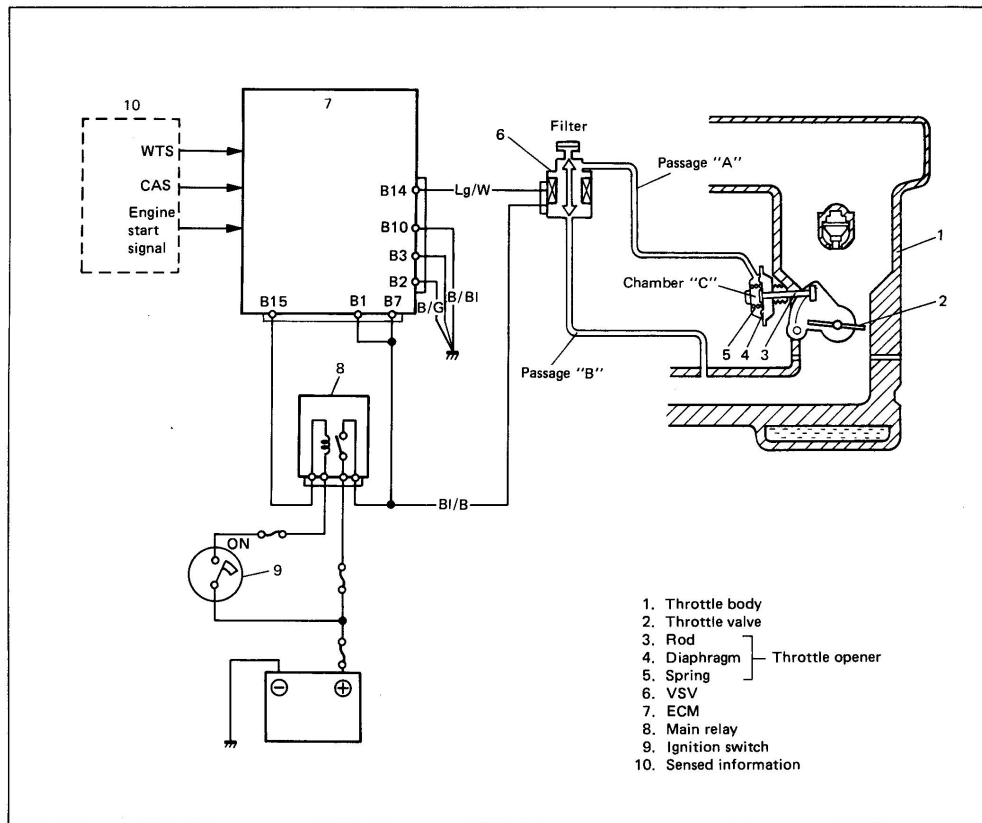

Fig. 4A-32 Throttle Opener Control System

EXHAUST GAS RECIRCULATION (EGR) CONTROL SYSTEM

This system controls the formation of NO_x emission by recirculating the exhaust gas into the combustion chamber through the intake manifold.

The EGR valve is controlled by EGR modulator and VSV controlled by ECM according to signals from various sensors.

The diaphragm mounted in the EGR modulator is operated by back pressure of the exhaust gas to open and close the valve. By this opening and closing action of the valve, the EGR modulator controls the vacuum transmitted to the EGR valve.

Under a low load condition such as low speed driving, the exhaust pressure is low. In this state, the diaphragm in the EGR modulator is pushed down by the spring force and the modulator valve opens to allow the air into the vacuum passage from the outside.

As a result, the vacuum transmitted to the EGR valve becomes smaller and so does the opening of the EGR valve.

Thus, less amount of exhaust gas is recirculated to the intake manifold.

Under a high load condition such as high speed driving, on the other hand, the exhaust pressure is high. By the high exhaust pressure, the diaphragm in the modulator is pushed up and closes its valve. As the air does not enter the vacuum passage in this state, the vacuum transmitted to the EGR valve grows larger and so does the opening of the EGR valve.

Thus, larger amount of exhaust gas is recirculated to the intake manifold.

Under any one of the following conditions, ECM closes the vacuum passage of VSV. In this state, as the vacuum is not transmitted to the EGR valve, it remains closed.

- When engine cooling water temperature is low
- When barometric pressure is low (at high altitude)
- When engine is running at high load
- When transmission is in 5th gear condition (Not for California spec. model)

Other than the above, EGR valve opens and closes in accordance with the EGR modulator operation.

Only California spec. model is equipped with REGTS (Recirculated Exhaust Gas Temperature Sensor).

The operation of EGR valves is monitored by ECM through the signal from the REGTS which measures the temperature in the exhaust passage. Should anything abnormal occur, "CHECK ENGINE" light turns ON to warn it.

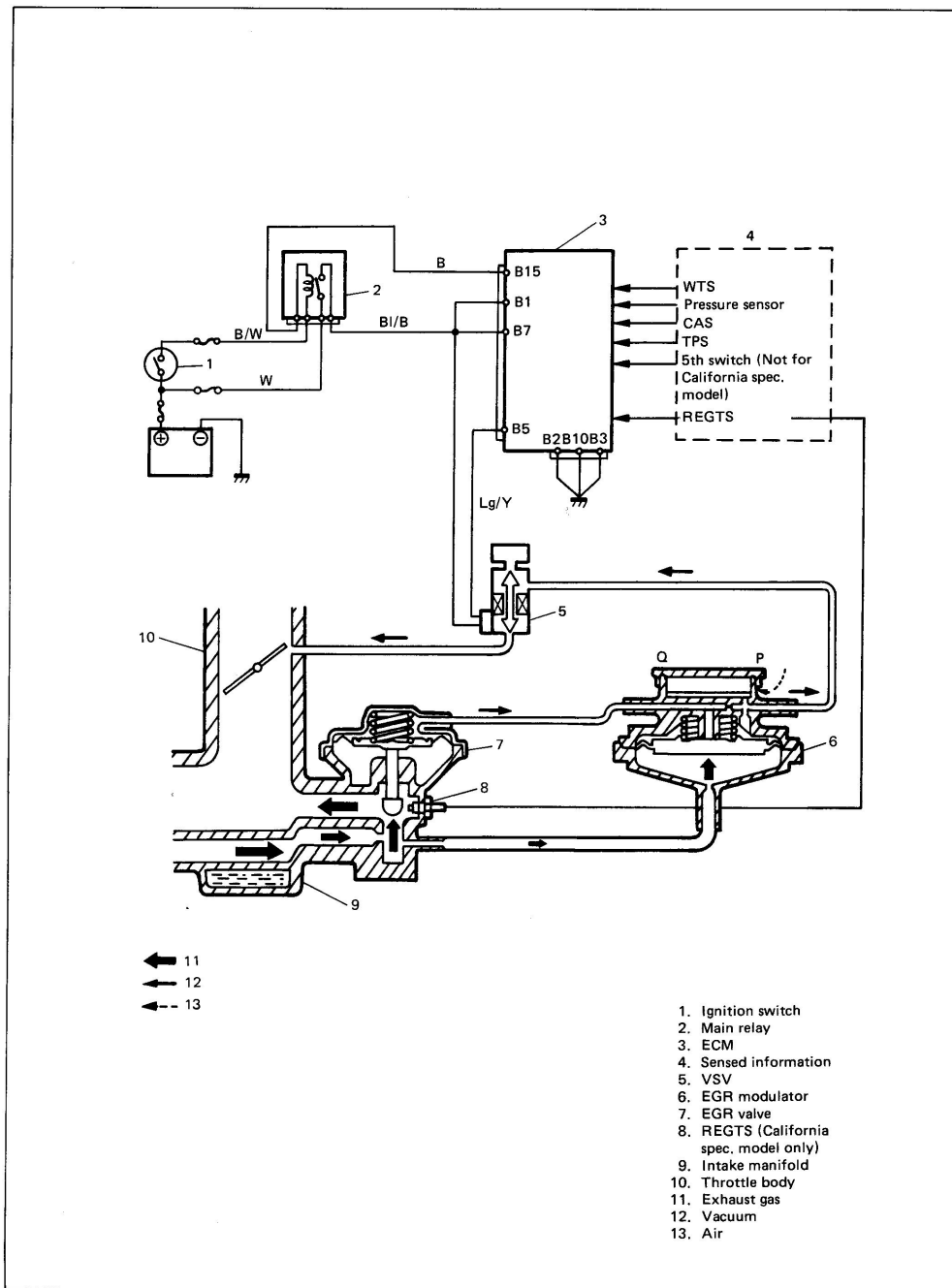

Fig. 4A-33 EGR Control System

ESA (ELECTRONIC SPARK ADVANCE) SYSTEM

This system controls electronically the time of electric current flow to ignition primary coil as well as ignition timing.

ECM judges the engine condition by using signals from various sensors, selects the most suitable electric current flow time and ignition timing for that engine condition from among those pre-stored in its memory and sends a signal to the igniter (power unit).

The igniter turns ON and OFF the primary current of the ignition coil according to the signal from ECM.

Control of this system includes four different types as follows.

- Ignition timing control at engine start
- Ignition timing control after engine start
- Electric current flow time control

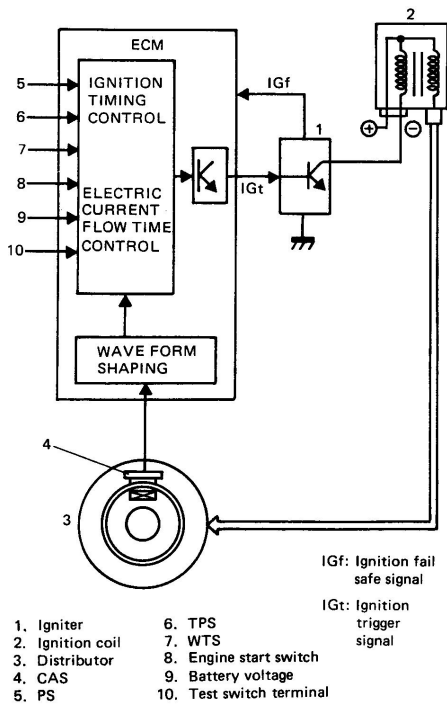

Fig. 4A-34 System Diagram

Ignition Timing Control at Engine Start

To obtain better starting performance of the engine at the engine start (when the engine start switch is turned ON or the engine speed is lower than 400 r/min.) ESA system sets the ignition timing to BTDC 5°.

Ignition Timing Control After Engine Start

Under any conditions other than engine start, the ignition timing is determined according to the intake manifold pressure and the engine speed.

Electric Current Flow Time Control

To stabilize the secondary voltage generated in the ignition coil to a proper level, ESA system controls the time of primary current flow to the ignition coil.

NOTE:

The ignition timing is controlled by ECM as described above. Therefore, when checking or adjusting the ignition timing, the ignition timing must be fixed by grounding the test switch terminal.

DIAGNOSIS

ECM has a system self-diagnosis function as described previously (p. 4A-15).

Investigate where the trouble is by referring to the following "Diagnostic Flow Chart" and "Diagnostic Code".

PRECAUTIONS IN DIAGNOSING TROUBLES

[PRECAUTIONS IN IDENTIFYING DIAGNOSTIC CODE]

- Before identifying diagnostic code indicated by "CHECK ENGINE" light, don't disconnect couplers from ECM, battery cable from battery, ECM ground wire harness from engine. Such disconnection will erase memorized trouble in ECM memory.
- If abnormality or malfunction lies in two or more areas, "CHECK ENGINE" light indicates applicable codes three times each. And flashing of these codes is repeated as long as diagnosis terminal is grounded (spare fuse is connected) and ignition switch is held at ON position.
- Take a note of diagnostic code indicated first.

[INTERMITTENT TROUBLES]

- There are cases where "CHECK ENGINE" light indicates a diagnostic code representing a trouble which occurred only temporarily and has gone. In such case, it may occur that good parts are replaced unnecessarily. To prevent such an accident, be sure to follow instructions given below when checking by using "Diagnostic Flow Chart".
 - * When trouble can be identified, that is, it is not an intermittent one:
Check sensor (actuator), wires and each connection and if they are all in good condition, substitute a known-good ECM and recheck.
 - * When trouble can not be identified but "CHECK ENGINE" light indicates a trouble code:

Diagnose trouble by using that code No. and if sensor (actuator), wires and each connection are all in good condition, erase diagnostic code in ECM memory. Then conduct a test run and check what "CHECK ENGINE" light indicates. Only when it indicates trouble code again, substitute a known-good ECM and check again.

If it indicates not trouble code but normal code No. 12, it means that an intermittent trouble did occur and has gone. In this case, check wires and connections carefully again.

[NOTES ON SYSTEM CIRCUIT INSPECTION]

- Intermittent troubles
 - Most intermittent problems are caused by faulty electrical connections or wiring. Perform careful check of suspect circuits for:
 - Poor mating of coupler halves, or terminals not fully seated in coupler body (backed out).
 - Improperly formed or damaged terminals. All coupler terminals in problem circuit should be carefully reformed to increase contact tension.
 - Poor terminal to wire connection.
- Never connect any tester (voltmeter, ohmmeter, or whatever) to ECM when its coupler is disconnected. Attempt to do it may cause damage to ECM.
- Never connect an ohmmeter to ECM with its coupler connected to it. Attempt to do it may cause damage to ECM and sensors.
- Be sure to use a voltmeter with high impedance ($M\Omega/V$ minimum) or a digital type voltmeter. Any other voltmeter should not be used because accurate measurements are not obtained.

- When checking voltage at each terminal of the coupler which is connected to ECM, be sure to negative probe to body ground. Any other way is prohibited even by accident. Applying it improperly may cause the sensor or ECM to be shorted and damaged.

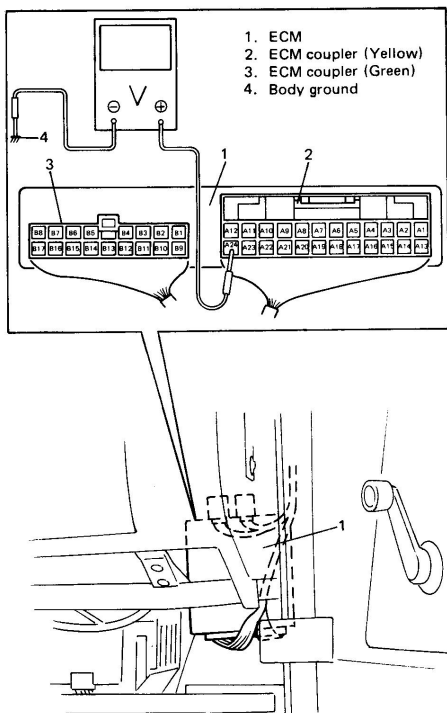

Fig. 4A-35 Checking Voltage and Terminal Position

- For ECM coupler terminal positions (A1, A2 . . . to A24 and B1, B2 . . . to B17), refer to Fig. 4A-35.
- When disconnecting and connecting coupler, make sure to turn ignition switch OFF.
- When there is a question "Are couplers connected properly?" in FLOW CHART, check male half of terminal for bend and female half for excessive opening, terminal for poor locking (looseness), corrosion, dust, etc.
- When connecting a probe of ohmmeter, voltmeter, etc. to coupler terminal, be sure to connect it from wire harness side of coupler.

4A-32

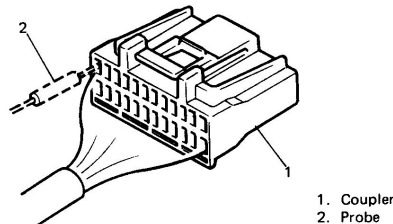

Fig. 4A-36 Connecting Meter Probe

- When connecting meter probe from terminal side of coupler because it can't be connected from harness side, use extra care not to bend male terminal of coupler or force its female terminal open for connection. In case of such coupler as shown below, connect probe as shown below to avoid opening female terminal. Never connect probe where male terminal is supposed to fit.

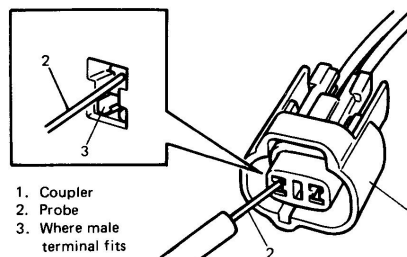

Fig. 4A-37 Connecting Meter Probe

- Before measuring voltage at each terminal, check to make sure that battery voltage is 11V or higher. Such terminal voltage check at low battery voltage will lead to erroneous diagnosis.

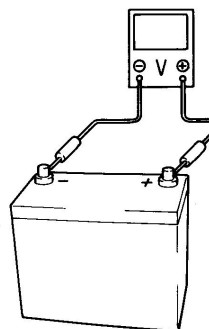

Fig. 4A-38 Checking Battery Voltage

DIAGNOSTIC FLOW CHART

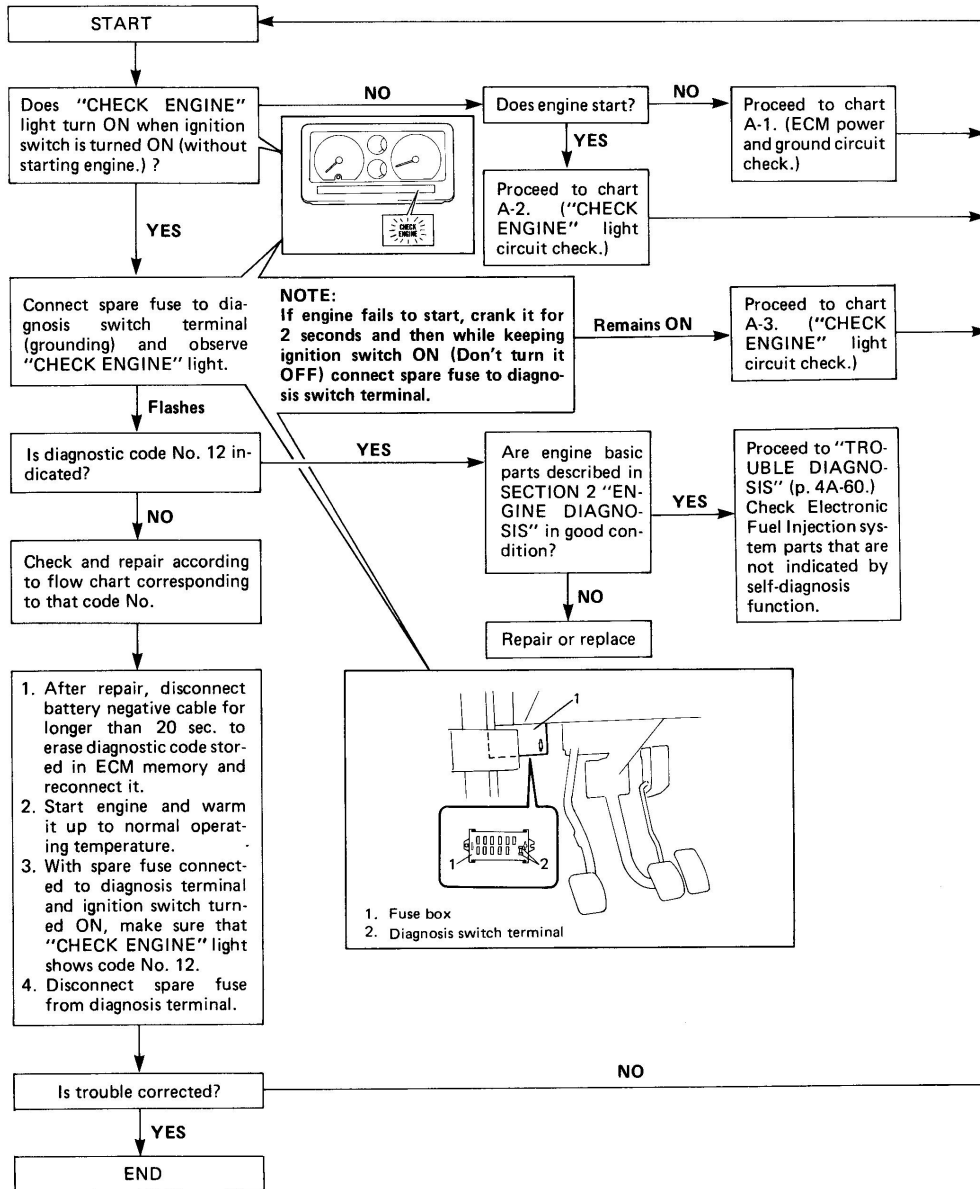

Fig. 4A-39 Diagnostic Flow Chart For Electronic Fuel Injection System

DIAGNOSIS CODE TABLE

EXAMPLE: When throttle position sensor is defective (Code No. 21)

DIAGNOSTIC CODE NO.	"CHECK ENGINE" LIGHT FLASHING PATTERN	DIAGNOSTIC ITEM	DIAGNOSIS
13		Oxygen sensor	Diagnose trouble according to "DIAGNOSTIC FLOW CHART" corresponding to each code No.
14		WTS	
15			
21		TPS	
22			
23		ATS	
25			
24		VSS	
31		Pressure sensor	
32			
41		Ignition signal	
42		CAS	
44		Idle switch of TPS	
45			
51		EGR system (For California spec. model only)	
53		Ground circuit (For California spec. model only)	
54		5th switch (Not for California spec. model)	
71		Test switch terminal	
ON		ECM	ECM failure.
12		Normal	This code appears when none of the other codes (Above codes) are identified.

Fig. 4A-40 Diagnostic Code Table

A-1 ECM POWER AND GROUND CIRCUIT CHECK

("CHECK ENGINE" LIGHT DOESN'T LIGHT AT IGNITION SWITCH ON AND ENGINE DOESN'T START THOUGH IT IS CRANKED UP.)

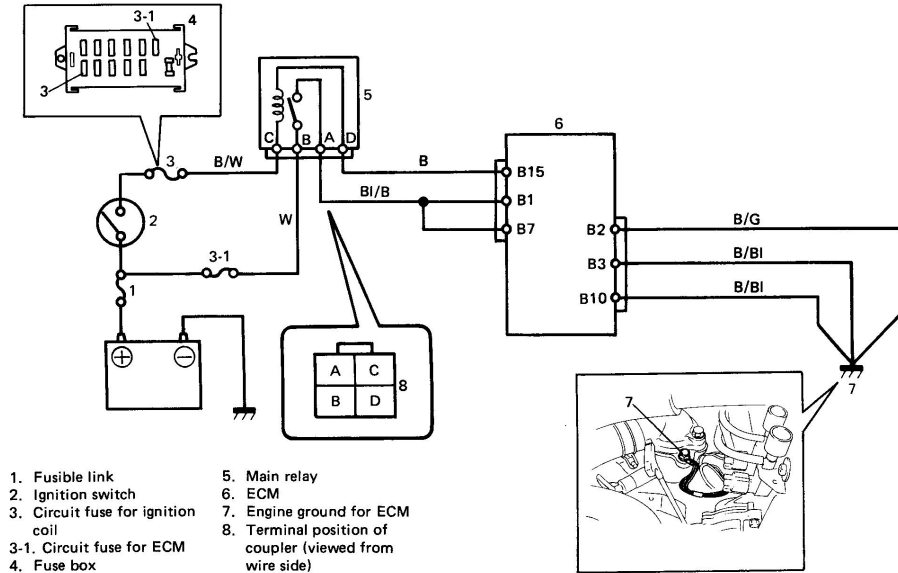
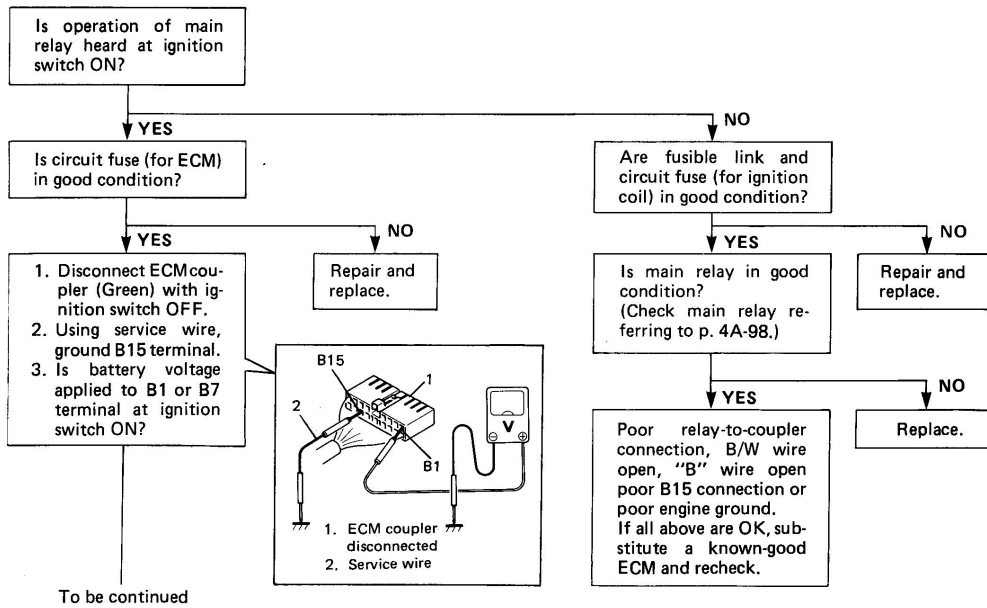

Fig. 4A-41 ECM Power and Ground Circuit



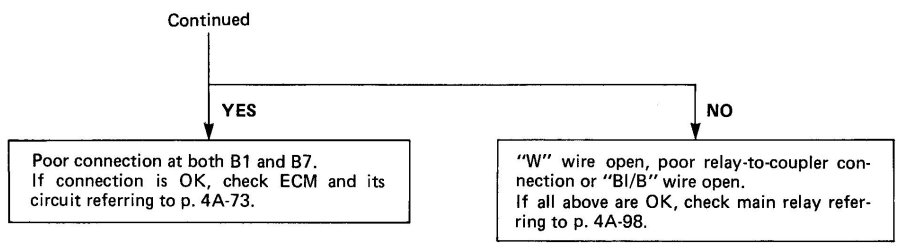

Fig. 4A-42 Diagnostic Flow Chart A-1 For ECM Power and Ground Circuit

A-2 "CHECK ENGINE" LIGHT CIRCUIT CHECK
 ("CHECK ENGINE" LIGHT DOESN'T LIGHT AT IGNITION SWITCH ON THOUGH ENGINE STARTS.)

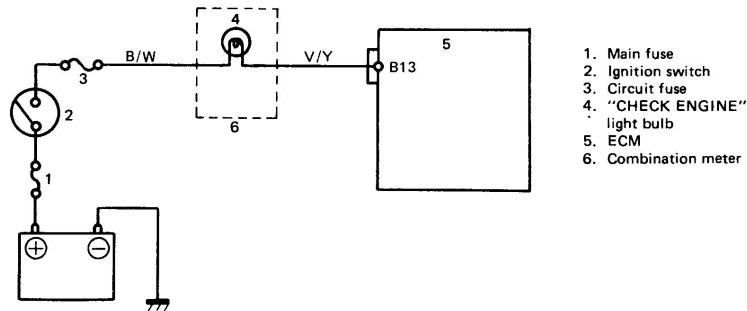

Fig. 4A-43 "CHECK ENGINE" Light Circuit

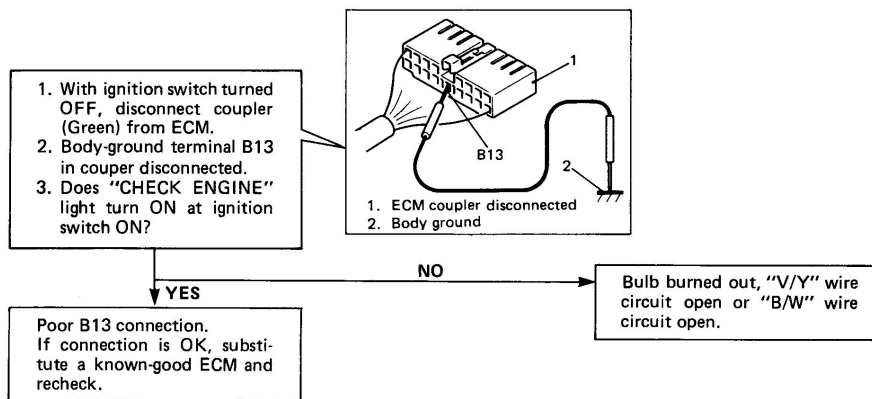

Fig. 4A-44 Diagnostic Flow Chart A-2 for "CHECK ENGINE" Light Circuit

A-3 "CHECK ENGINE" LIGHT CIRCUIT CHECK
 ("CHECK ENGINE" LIGHT DOESN'T FLASH OR JUST REMAINS ON EVEN WITH SPARE FUSE CONNECTED TO DIAGNOSIS SWITCH TERMINAL.)

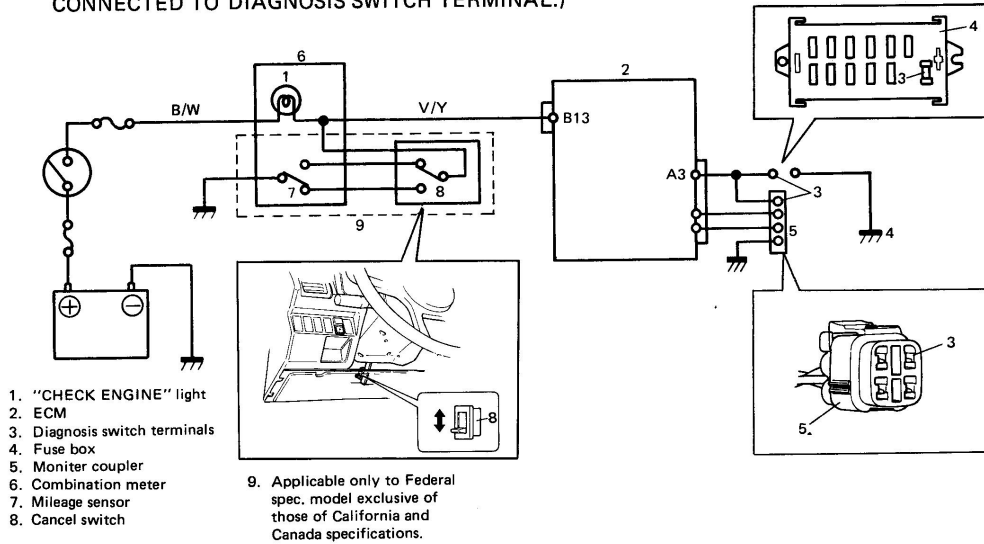

Fig. 4A-45 "CHECK ENGINE" Light Circuit

For California and Canada Spec. Model

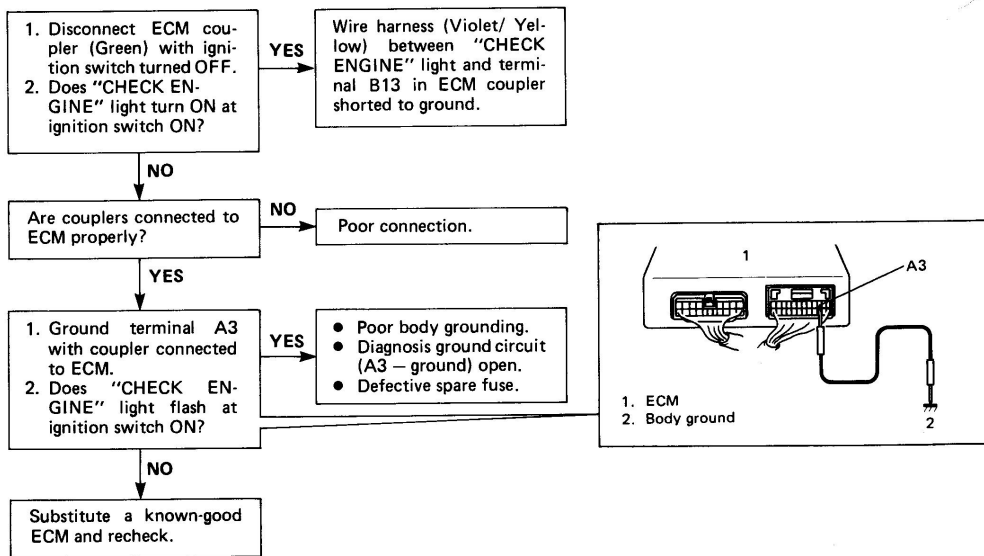

Fig. 4A-46 Diagnostic Flow Chart A-3 For "CHECK ENGINE" Light Circuit
 (For California and Canada spec. model)

For Federal Spec. Model Except California and Canada

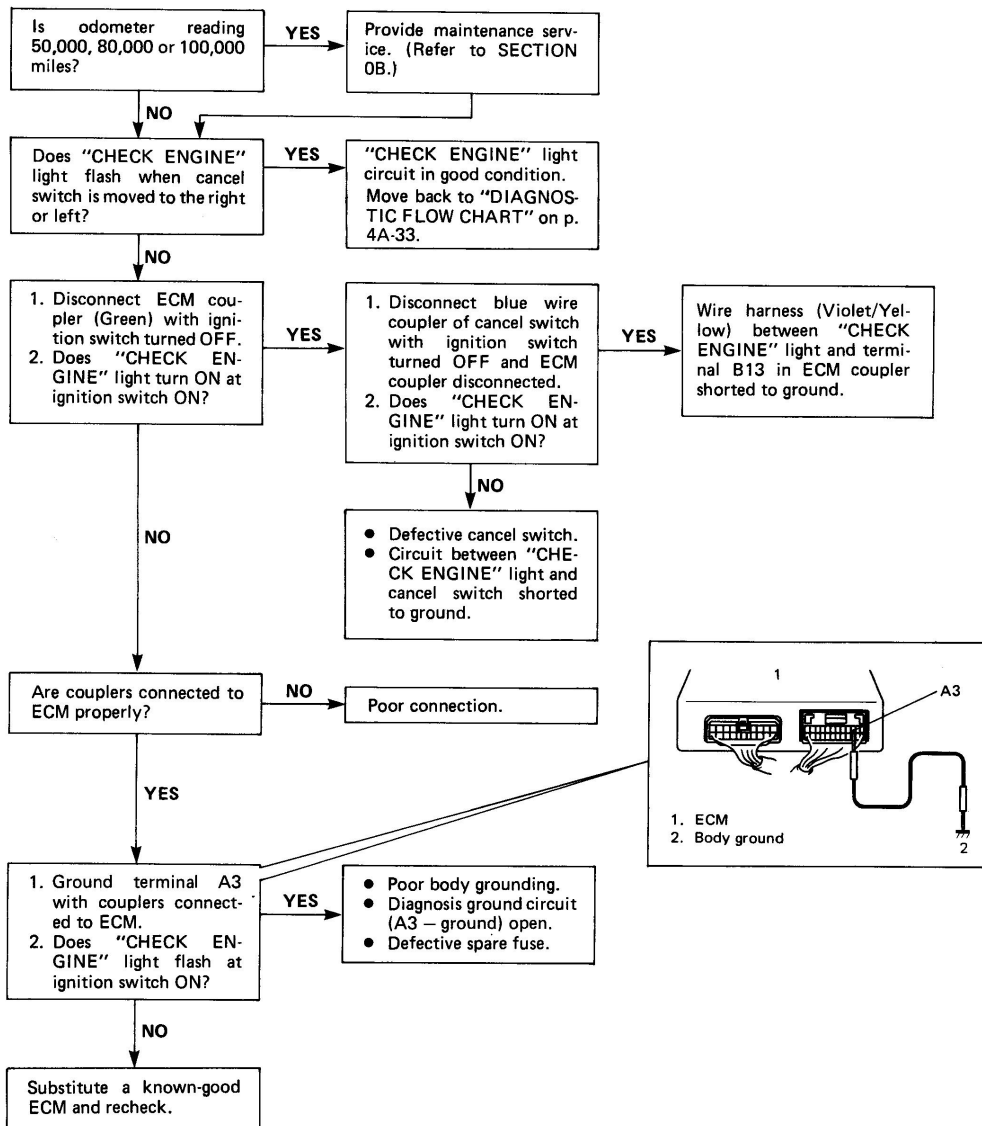

Fig. 4A-47 Diagnostic Flow Chart A-3 For "CHECK ENGINE" Light Circuit (For Federal spec. model Except California and Canada)

CODE NO. 13 OXYGEN SENSOR CIRCUIT (SIGNAL VOLTAGE LOW AND DOESN'T CHANGE)

NOTE:

- Before diagnosing trouble according to flow chart given below, check to make sure that following system and parts other than Electronic Fuel Injection system are in good condition.
 - Air cleaner (clogged)
 - Vacuum leaks (air inhaling)
 - Spark plugs (contamination, gap)
 - High tension cords (crack, deterioration)
 - Distributor rotor or cap (wear, crack)
 - Ignition timing
 - Engine compression
 - Any other system and parts which might affect A/F mixture or combustion.
- If code No. 13 and another code No. are indicated together, the latter has priority. Therefore, check and correct what is represented by that code No. first and then proceed to the following check.

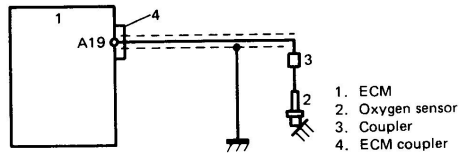
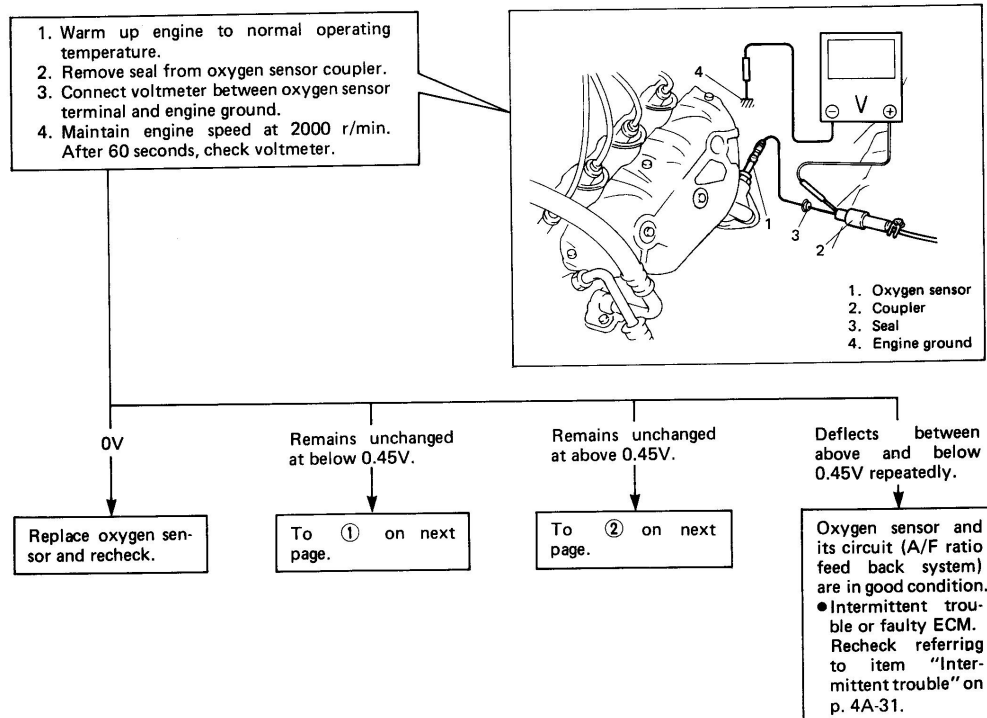

Fig. 4A-48 Oxygen Sensor Circuit



CODE NO. 13 OXYGEN SENSOR CIRCUIT (Continued)

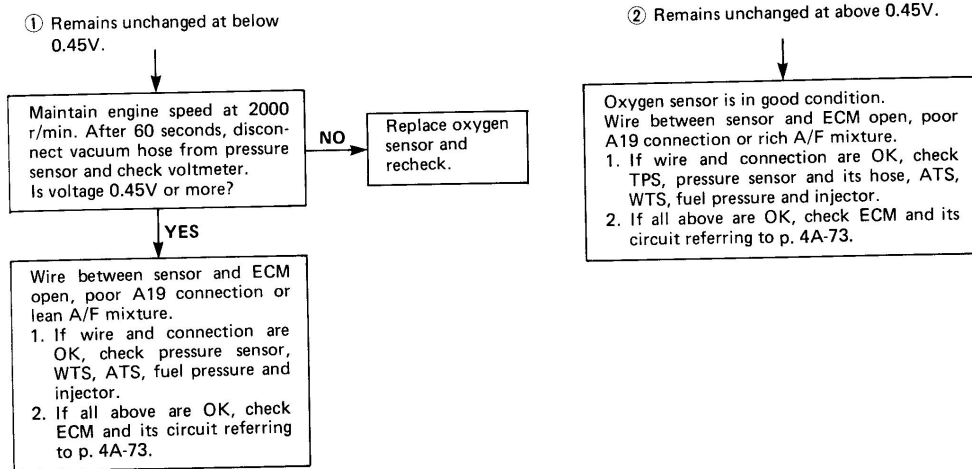
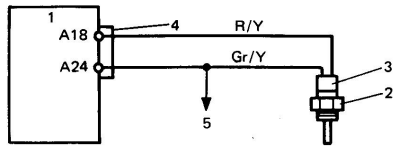

Fig. 4A-49 Diagnostic Flow Chart For Code No. 13

CODE NO. 14 WTS (WATER TEMPERATURE SENSOR) CIRCUIT (LOW TEMPERATURE INDICATED, SIGNAL VOLTAGE HIGH)



- 1. ECM
- 2. WTS
- 3. Coupler
- 4. ECM coupler
- 5. To other sensors

NOTE:

When Code Nos. 14, 21, 23, 31 and 44 are indicated together, it is possible that "Gr/Y" wire is open or A24 terminal connection is poor.

Fig. 4A-50 WTS Circuit

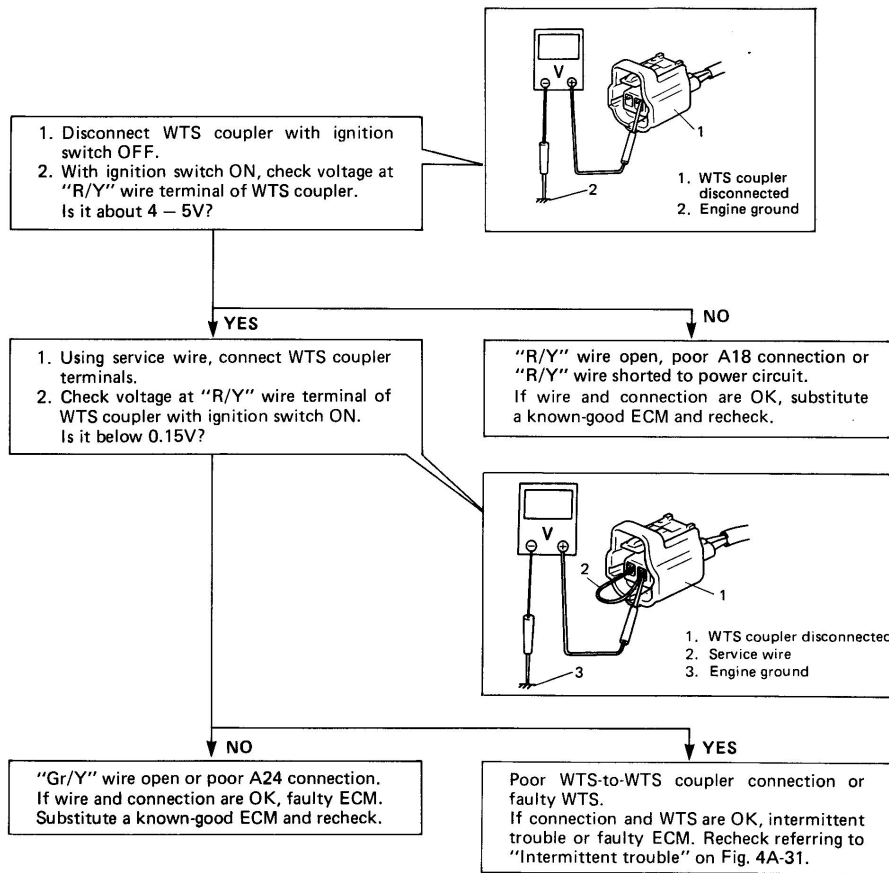

Fig. 4A-51 Diagnostic Flow Chart For Code No. 14

CODE NO. 15 WTS (WATER TEMPERATURE SENSOR) CIRCUIT (HIGH TEMPERATURE INDICATED, SIGNAL VOLTAGE LOW)

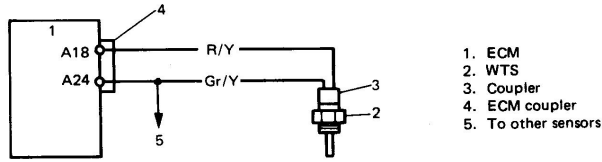

Fig. 4A-52 WTS Circuit

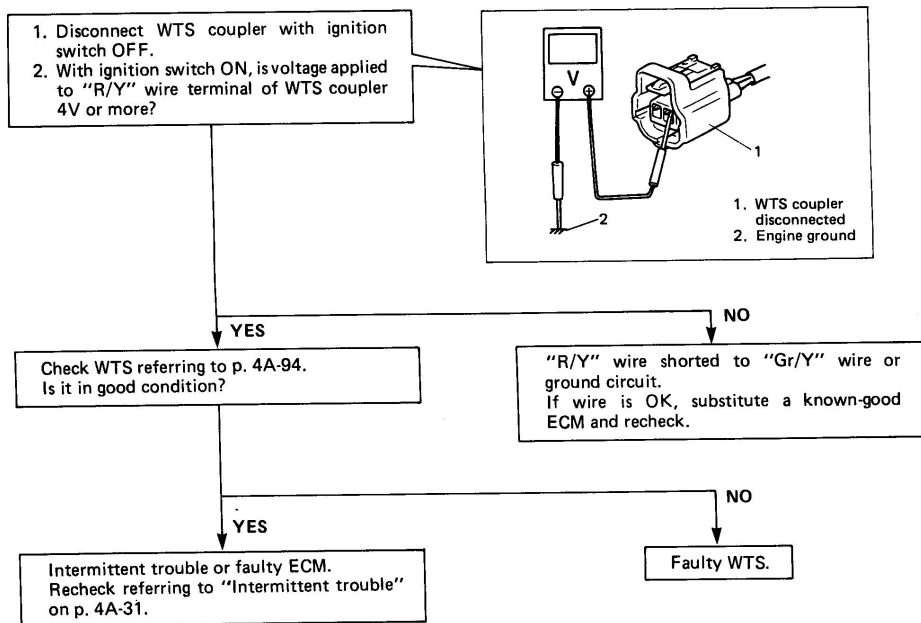

Fig. 4A-53 Diagnostic Flow Chart For Code No. 15

CODE NO. 21 TPS (THROTTLE POSITION SENSOR) CIRCUIT (SIGNAL VOLTAGE HIGH)

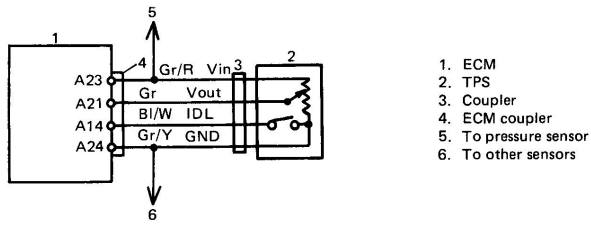

Fig. 4A-54 TPS Circuit

NOTE:

Be sure to turn OFF ignition switch for this check.

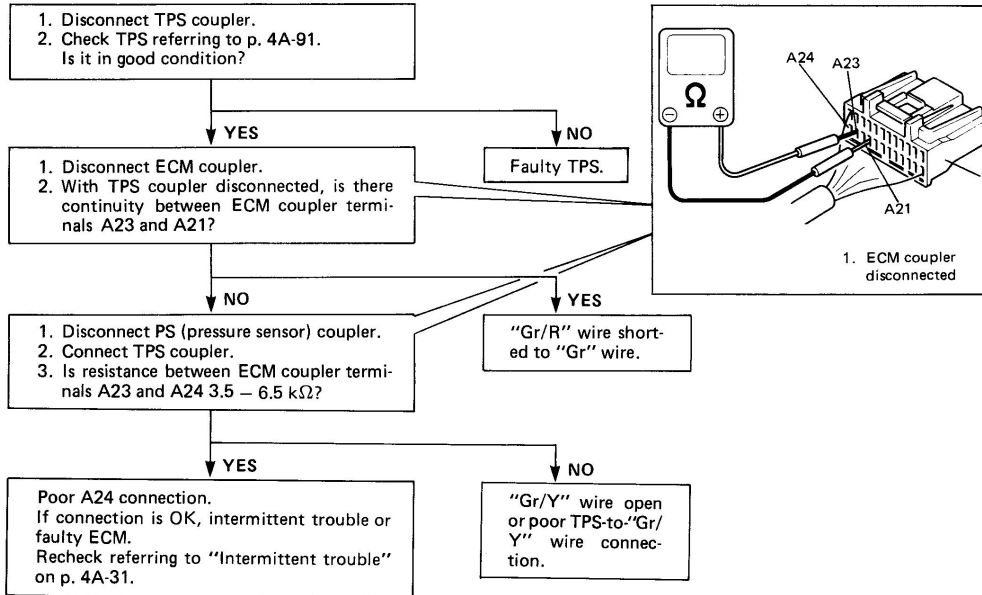

Fig. 4A-55 Diagnostic Flow Chart For Code No. 21

CODE NO. 22 TPS (THROTTLE POSITION SENSOR) CIRCUIT (SIGNAL VOLTAGE LOW)

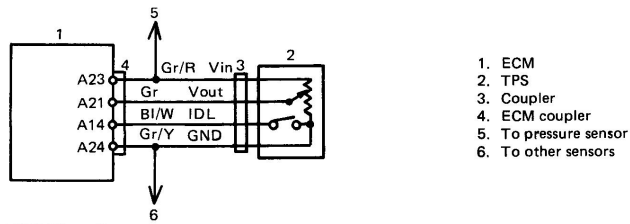

Fig. 4A-56 TPS Circuit

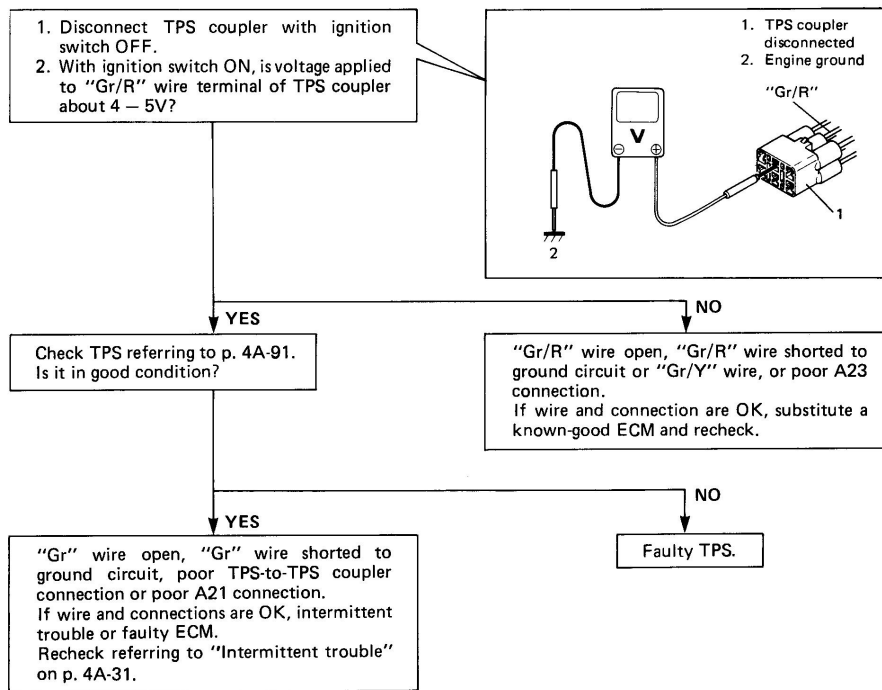

Fig. 4A-57 Diagnostic Flow Chart For Code No. 22

CODE NO. 23 ATS (AIR TEMPERATURE SENSOR) CIRCUIT (LOW TEMPERATURE INDICATED, SIGNAL VOLTAGE HIGH)

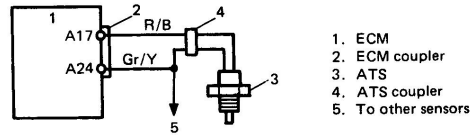

Fig. 4A-58 ATS Circuit

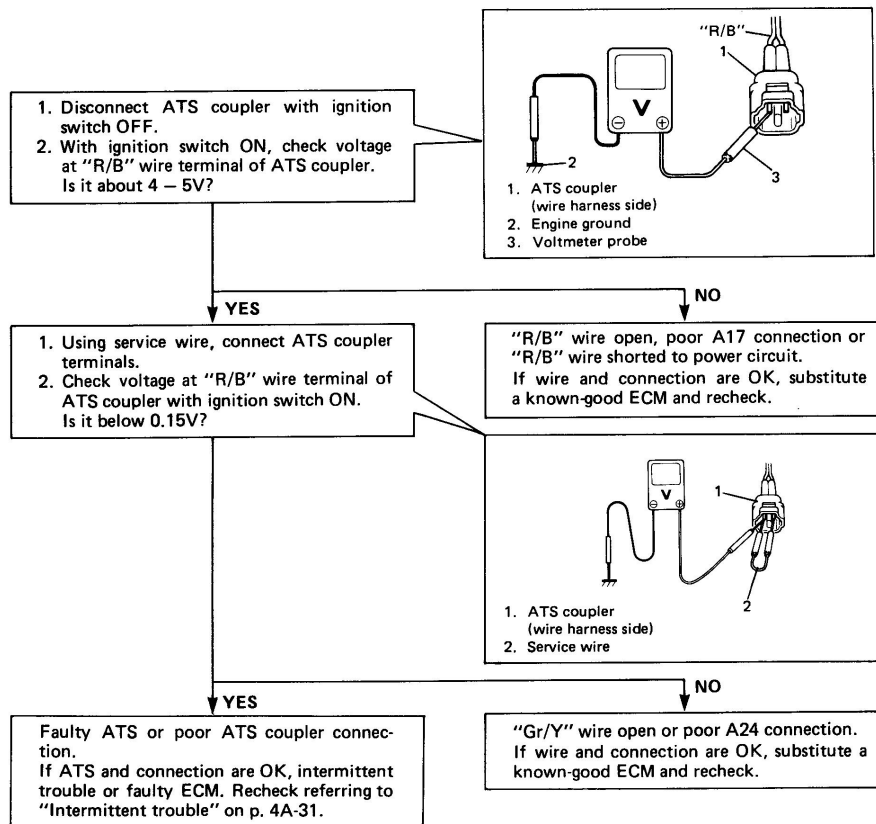

Fig. 4A-59 Diagnostic Flow Chart For Code No. 23

CODE NO. 25 ATS (AIR TEMPERATURE SENSOR) CIRCUIT (HIGH TEMPERATURE INDICATED, SIGNAL VOLTAGE LOW)

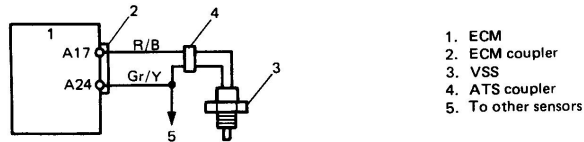

Fig. 4A-60 ATS Circuit

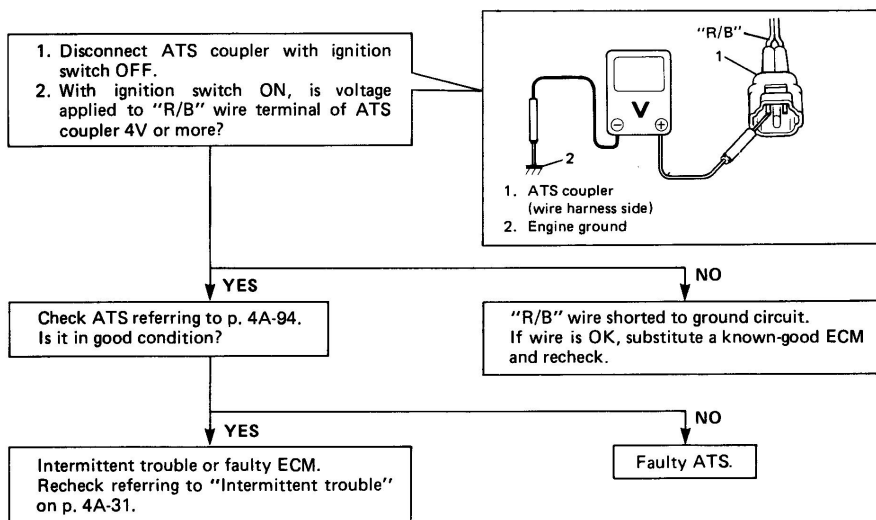
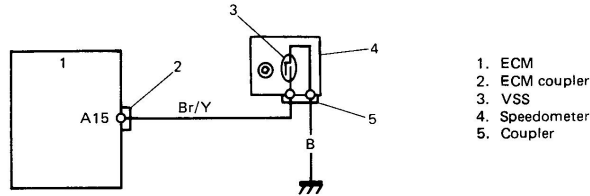

Fig. 4A-61 Diagnostic Flow Chart For Code No. 25

CODE NO. 24 VSS (VEHICLE SPEED SENSOR) CIRCUIT

(VEHICLE SPEED LOWER THAN 1.4 km/h (0.9 mile/h) ALTHOUGH FUEL IS KEPT CUT FOR LONGER THAN 10 SECONDS)



- 1. ECM
- 2. ECM coupler
- 3. VSS
- 4. Speedometer
- 5. Coupler

NOTE:
Be sure to turn OFF ignition switch for this check.

Fig. 4A-62 VSS Circuit

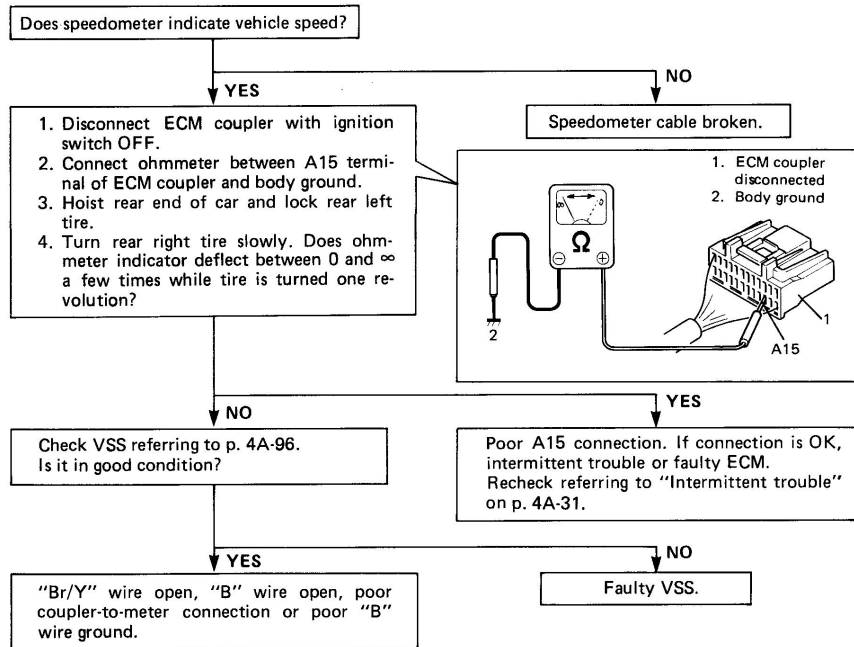

Fig. 4A-63 Diagnostic Flow Chart For Code No. 24

CODE NO. 31 PS (PRESSURE SENSOR) CIRCUIT (SIGNAL VOLTAGE HIGH—HIGH PRESSURE—LOW VACUUM)

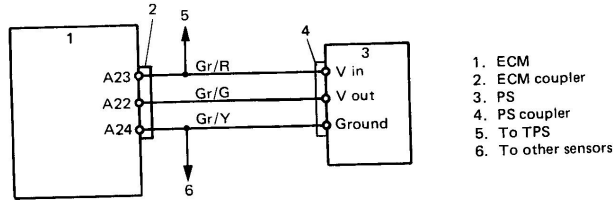

Fig. 4A-64 PS Circuit

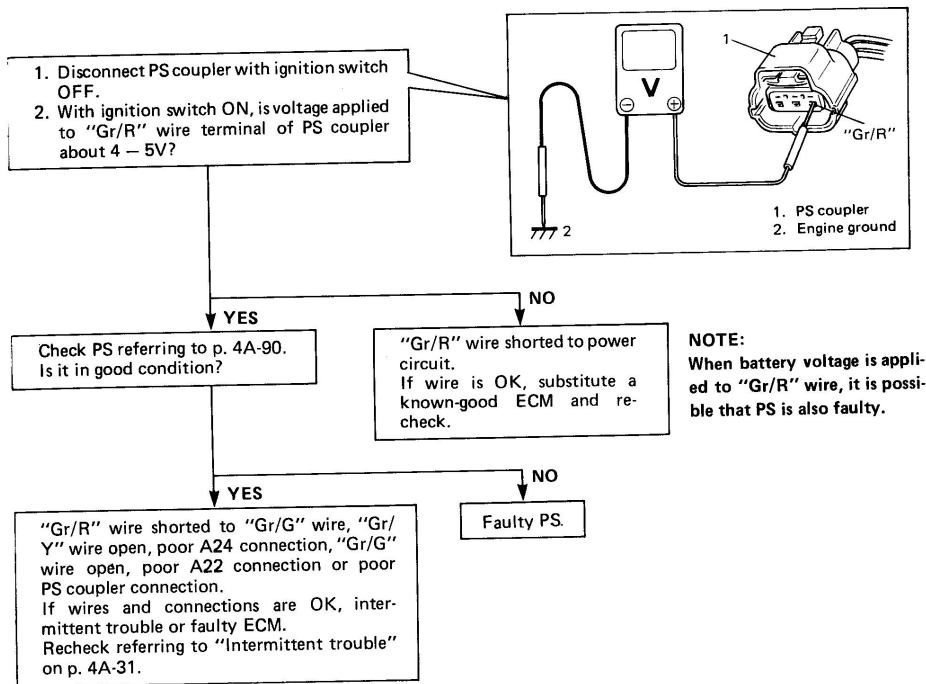

Fig. 4A-65 Diagnostic Flow Chart For Code No. 31

CODE NO. 32 PS (PRESSURE SENSOR) CIRCUIT (SIGNAL VOLTAGE LOW—LOW PRESSURE—HIGH VACUUM)

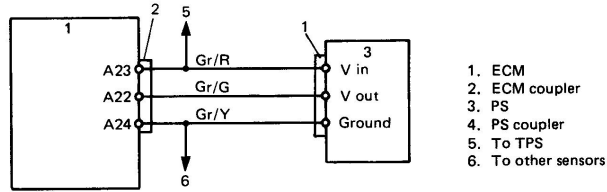

Fig. 4A-66 PS Circuit

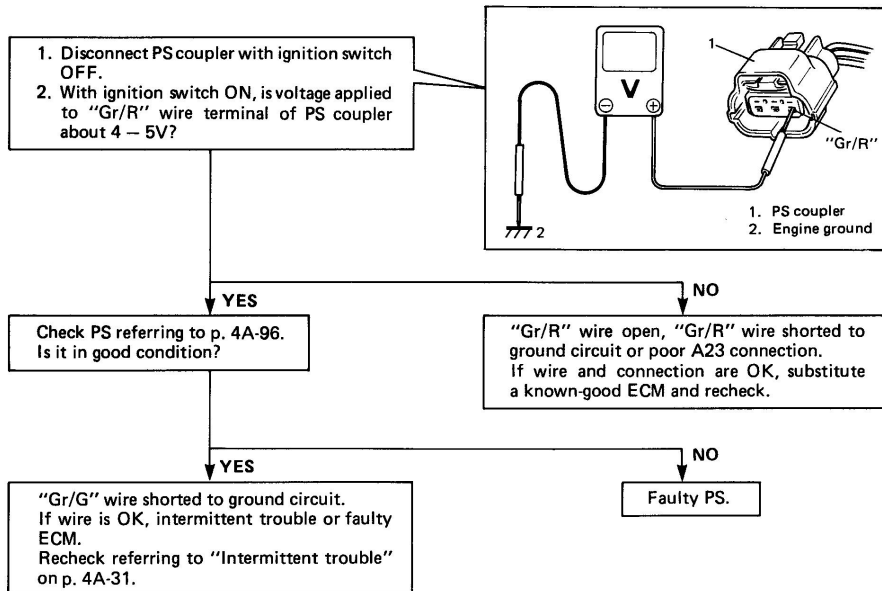

Fig. 4A-67 Diagnostic Flow Chart For Code No. 32

CODE NO. 41 IGNITION SIGNAL CIRCUIT (IGNITION FAIL SAFE SIGNAL NOT INPUTTED 6 TIMES CONTINUOUSLY)

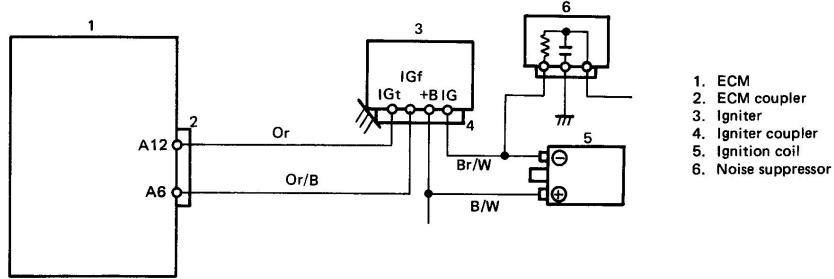

Fig. 4A-68 Ignition Signal Circuit

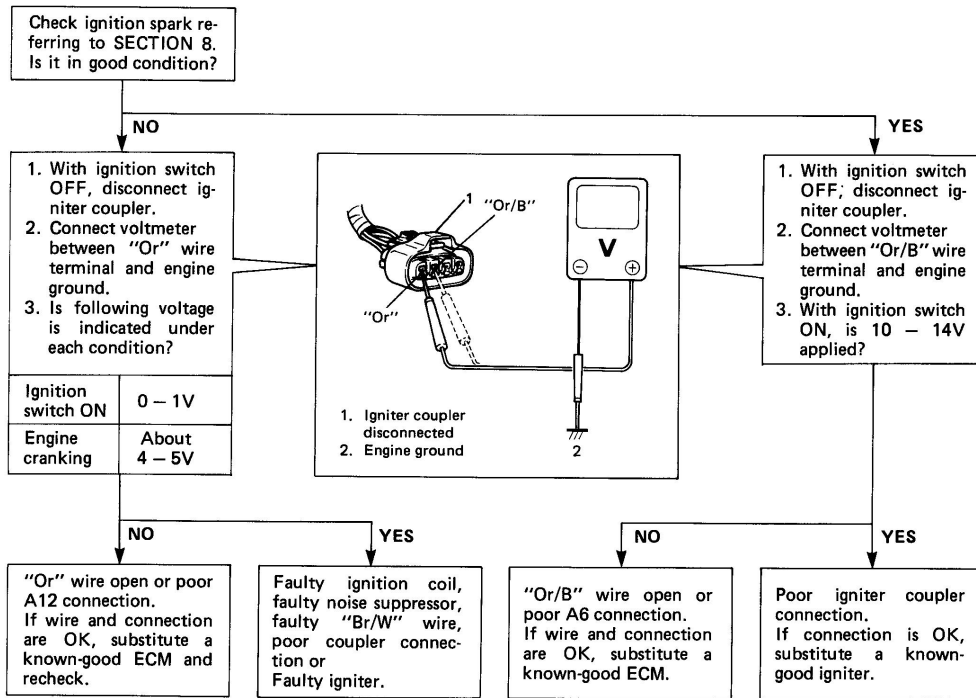

Fig. 4A-69 Diagnostic Flow Chart For Code No. 41

CODE NO. 42 CAS (CRANK ANGLE SENSOR) CIRCUIT (SENSOR SIGNAL NOT INPUTTED FOR 3 SECONDS AT ENGINE CRANKING)

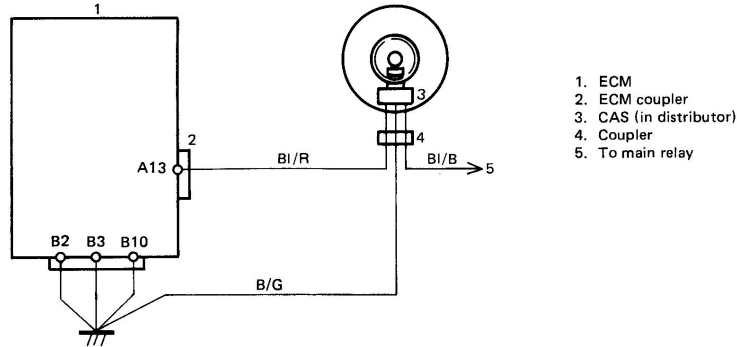

Fig. 4A-70 CAS Circuit

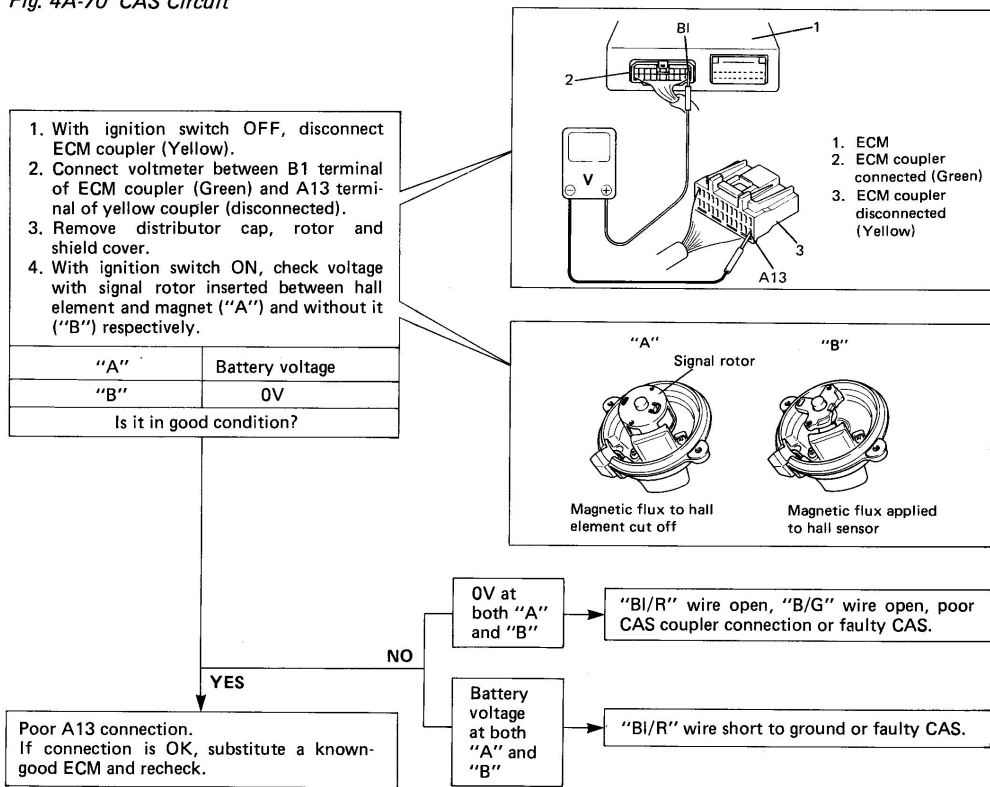

Fig. 4A-71 Diagnostic Flow Chart For Code No. 42

4A-52

CODE NO. 44 IDLE SWITCH CIRCUIT (CIRCUIT OPEN OR TPS INSTALLATION ANGLE MALADJUSTED)

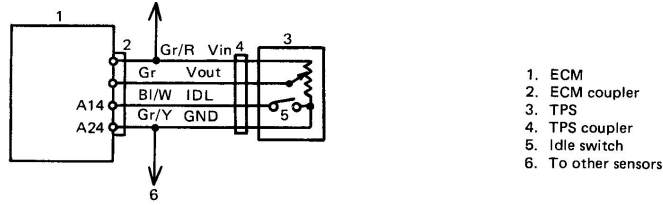

Fig. 4A-72 Idle Switch Circuit

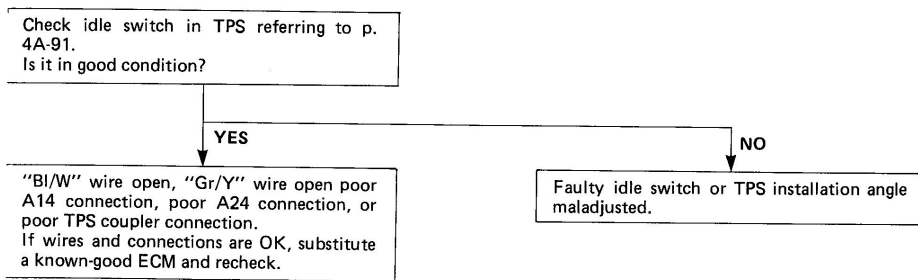

Fig. 4A-73 Diagnostic Flow Chart For Code No. 44

CODE NO. 45 IDLE SWITCH CIRCUIT (CIRCUIT SHORT OR TPS INSTALLATION ANGLE MALADJUSTED)

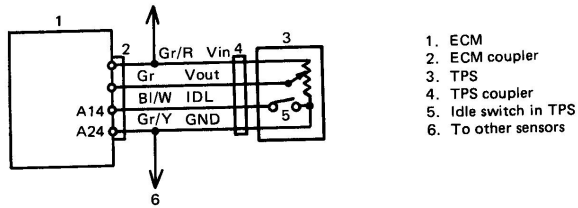

Fig. 4A-74 Idle Switch Circuit

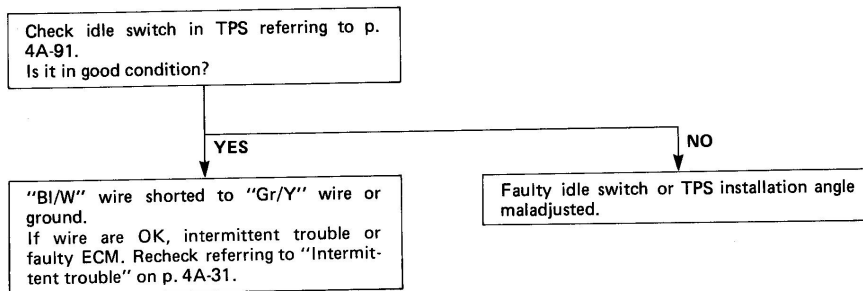

Fig. 4A-75 Diagnostic Flow Chart For Code No. 45

CODE NO. 51 EGR SYSTEM AND REGTS (RECIRCULATED EXHAUST GAS TEMPERATURE SENSOR) CIRCUIT (LOW TEMPERATURE INDICATED)

California spec. model only

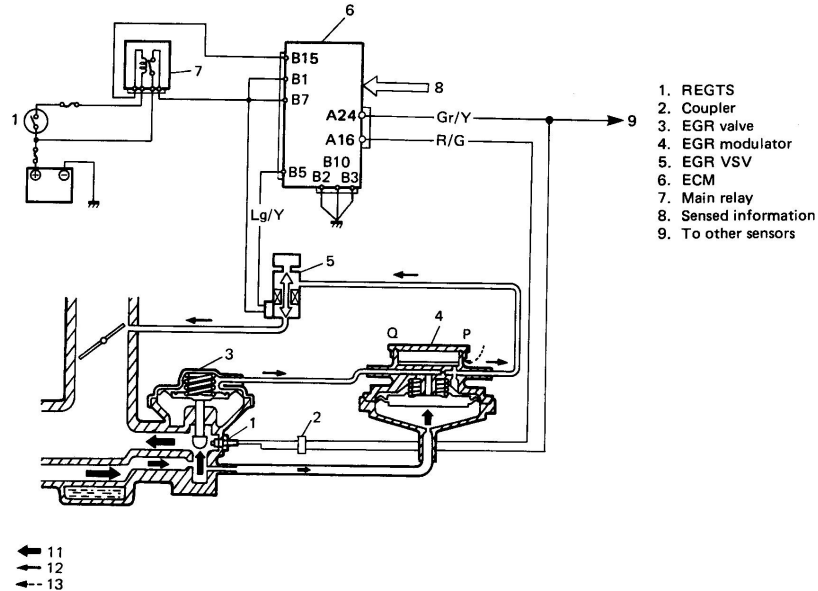

Fig. 4A-76 EGR System (California spec. model only)

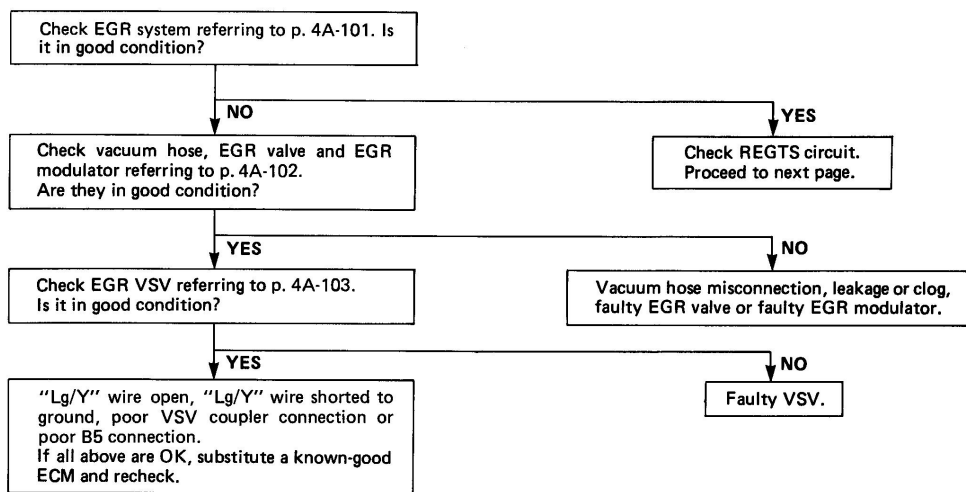

Fig. 4A-77 Diagnostic Flow Chart For Code No. 51 (1) (California spec. model only)

CODE NO. 51 (CONTINUED)

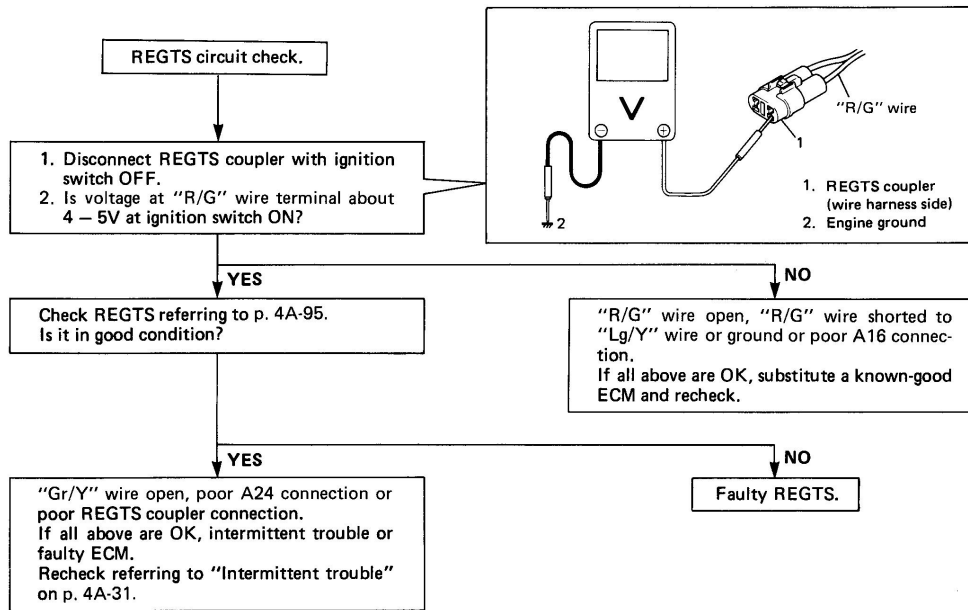

Fig. 4A-78 Diagnostic Flow Chart For Code No. 51 (2) (California spec. model only)

CODE NO. 53 GROUND CIRCUIT FOR CALIFORNIA SPEC. MODEL ONLY (CIRCUIT OPEN)

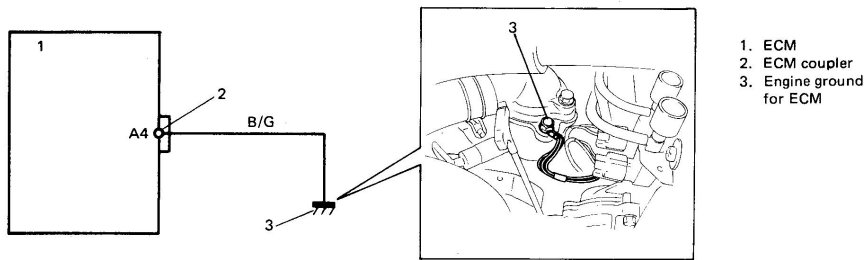

Fig. 4A-79 Ground Circuit (California spec. model only)

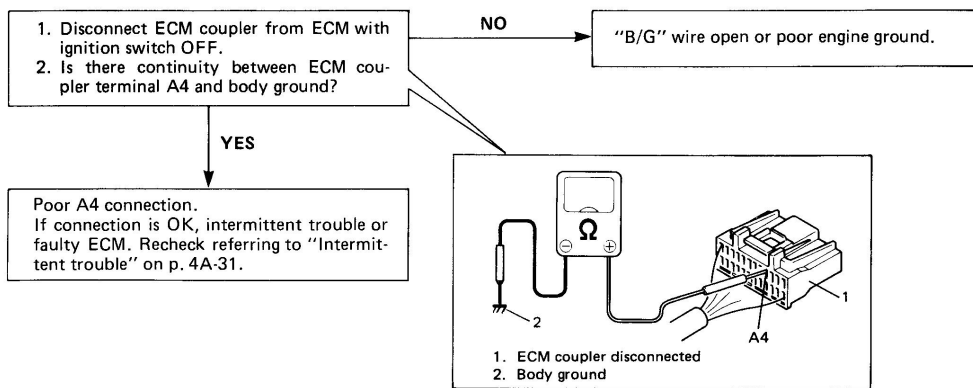
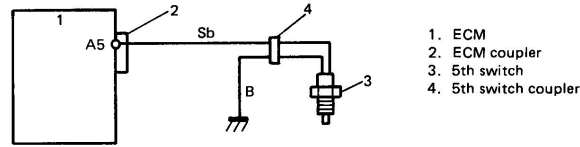

Fig. 4A-80 Diagnostic Flow Chart For Code No. 53 (California spec. model only)

CODE NO. 54 5TH SWITCH CIRCUIT (A5 TERMINAL GROUNDED—5TH SWITCH ON CONSTANTLY)

NOT FOR CALIFORNIA SPEC. MODEL



- 1. ECM
- 2. ECM coupler
- 3. 5th switch
- 4. 5th switch coupler

Fig. 4A-81 5th Switch Circuit (Not for California spec. model)

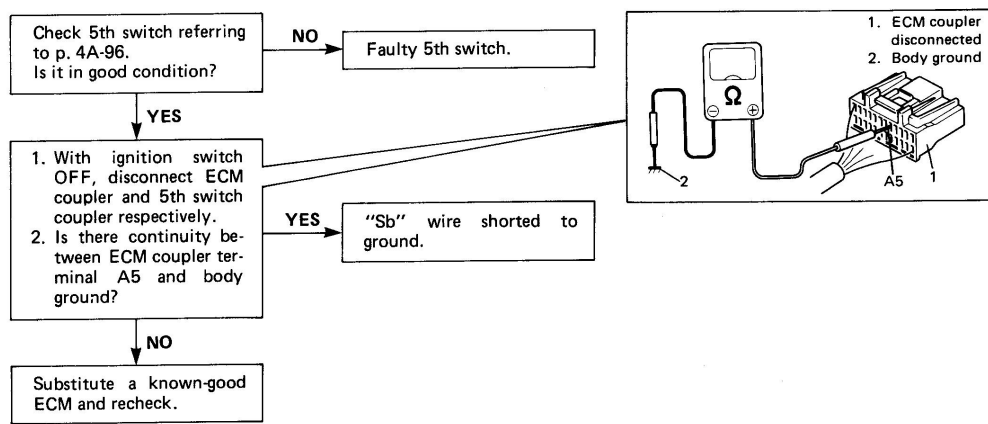

Fig. 4A-82 Diagnostic Flow Chart For Code No. 54 (Not for California spec. model)

CODE NO. 71 TEST SWITCH CIRCUIT (TEST SWITCH CIRCUIT GROUNDED FOR 5 SECONDS EVEN WHEN DRIVING AT 40 km/h (25 mile/h) OR HIGHER)

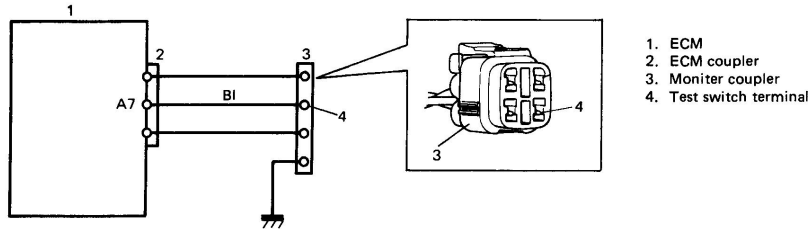

Fig. 4A-83 Test Switch Circuit

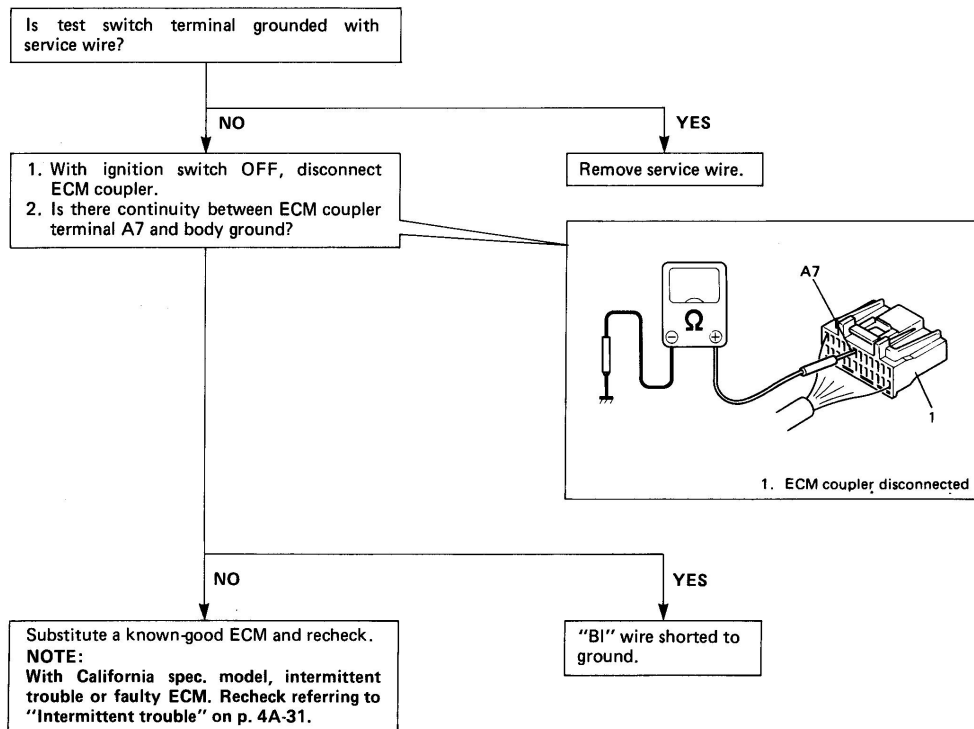

Fig. 4A-84 Diagnostic Flow Chart For Code No. 71

TROUBLE DIAGNOSIS

This section describes trouble diagnosis of Electronic Fuel Injection system parts whose trouble is not indicated by the self-diagnosis function.

When diagnostic code No. 12 is indicated by the self-diagnosis function and assuredly those engine basic parts as described in "ENGINE DIAGNOSIS" are all in good condition, check below Electronic Fuel Injection system parts which may be a possible cause for each symptom of the engine.

SYMPTOM	POSSIBLE CAUSE	INSPECTION
Hard or no starting (Engine cranks OK)	<ul style="list-style-type: none"> ● Shortage of fuel in fuel tank ● Faulty fuel pump or its circuit open 	Check if fuel pressure is felt at fuel return hose for 3 seconds after ignition switch ON. If not, advance to Diagnostic flow chart B-2 Diagnostic flow chart B-1 Diagnostic flow chart B-3 See p. 4A-84 Check voltage at ECM coupler terminal B11 (refer to p. 4A-73) Diagnostic flow chart B-4 See p. 4A-94, 4A-94 or 4A-90 See p. 4A-73
	<ul style="list-style-type: none"> ● Injector or its circuit defective ● Fuel pressure out of specification ● Faulty air valve ● Open starter signal circuit 	
NOTE: <ul style="list-style-type: none"> ● If engine doesn't start at all, perform fuel injector and its circuit check first. (Advance to Diagnostic flow chart B-1.) ● If engine is hard to start only when it is cold, check air valve first and then engine starter signal circuit. ● If engine starts easily with help of accelerator pedal operation, check throttle opener system first. (Advance to Diagnostic flow chart B-4.) 		
Engine fails to idle	<ul style="list-style-type: none"> ● Shortage of fuel in fuel tank ● Faulty ISC solenoid valve control system ● Maladjusted idle speed adjusting screw ● Faulty air valve ● Faulty EGR system ● Fuel pressure out of specification ● Faulty injector 	Diagnostic flow chart B-5 See p. 4A-78 See p. 4A-84 See p. 4A-101 Diagnostic flow chart B-3 Check injector for resistance injection condition and fuel leakage (Refer to p. 4A-87)

SYMPTOM	POSSIBLE CAUSE	INSPECTION
Engine fails to idle	<ul style="list-style-type: none"> ● Poor performance of WTS, ATS or pressure sensor ● Faulty ECM 	<p>See p. 4A-94, 4A-94, 4A-90</p> <p>See p. 4A-73</p>
<p>NOTE: If engine fails to idle when it is cold, check air valve first.</p>		
Improper engine idle speed	<ul style="list-style-type: none"> ● Maladjusted accelerator cable play ● Clogged pressure sensor vacuum passage ● Faulty throttle opener system ● Faulty ISC solenoid valve control system ● Faulty A/C VSV ● Maladjusted idle speed adjusting screw ● Faulty air valve ● Fuel pressure out of specification ● Faulty injector ● Poor performance of WTS, ATS or pressure sensor ● Faulty ECM 	<p>See p. 4A-78</p> <p>Check vacuum hose and filter</p> <p>Diagnostic flow chart B-4</p> <p>Diagnostic flow chart B-5</p> <p>See p. 4A-78</p> <p>See p. 4A-84</p> <p>Diagnostic flow chart B-3</p> <p>Check injector for resistance injection condition and fuel leakage (Refer to p. 4A-87)</p> <p>See p. 4A-94, 4A-94 or 4A-90</p> <p>See p. 4A-73</p>
<p>NOTE: If engine idle speed lowers below specification only when electric load (e.g. headlight ON), check ISC solenoid valve control system first.</p>		
Engine has no or poor power	<ul style="list-style-type: none"> ● Clogged pressure sensor vacuum passage ● Maladjusted accelerator cable play ● Maladjusted installation angle of throttle position sensor ● Fuel pressure out of specification (Low fuel pressure) ● Faulty EGR system ● Faulty injector ● Poor performance of TPS, WTS, ATS or pressure sensor ● Faulty ECM 	<p>Check vacuum hose and filter</p> <p>See p. 4A-78</p> <p>See p. 4A-92</p> <p>Diagnostic flow chart B-3</p> <p>Diagnostic flow chart B-6</p> <p>Check injector for resistance, injection condition and fuel leakage. (Refer to p. 4A-87)</p> <p>See p. 4A-91, 4A-94, 4A-94 or 4A-90</p> <p>See p. 4A-73</p>

SYMPTOM	POSSIBLE CAUSE	INSPECTION
Engine hesitates when acceleration	<ul style="list-style-type: none"> ● Clogged pressure sensor vacuum passage ● Defective throttle valve operation ● Poor performance TPS ● Fuel pressure out of specification (Low fuel pressure) ● Faulty EGR system ● Faulty injector ● Poor performance of WTS or pressure sensor ● Faulty ECM 	<p>Check vacuum hose and filter</p> <p>Check throttle valve for smooth operation</p> <p>See p. 4A-91</p> <p>Diagnostic flow chart B-3</p> <p>Diagnostic flow chart B-6</p> <p>Check injector for resistance, injection condition and fuel leakage (Refer to p. 4A-87)</p> <p>See p. 4A-94 or 4A-90</p> <p>See p. 4A-73</p>
Surges (Variation in vehicle speed is felt although accelerator pedal is not operated)	<ul style="list-style-type: none"> ● Variable fuel pressure (Clogged fuel filter, defective fuel pressure regulator etc.) ● Defective EGR system ● Defective injector ● Poor performance of TPS, WTS or pressure sensor ● Faulty ECM 	<p>Diagnostic flow chart B-3</p> <p>Diagnostic flow chart B-6</p> <p>Check injector for resistance, injection condition and fuel leakage (Refer to p. 4A-87)</p> <p>See p. 4A-91, 4A-94 or 4A-90</p> <p>See p. 4A-73</p>
Excessive detonation (Engine makes sharp metallic knocks that change with throttle opening)	<ul style="list-style-type: none"> ● Low fuel pressure ● Defective EGR system ● Defective injector ● Poor performance of TPS, WTS or pressure sensor ● Faulty ECM 	<p>Diagnostic flow chart B-3</p> <p>Diagnostic flow chart B-6</p> <p>Check injector for resistance, injection condition and fuel leakage (Refer to p. 4A-87)</p> <p>See p. 4A-91, 4A-94 or 4A-90</p> <p>See p. 4A-73</p>
Poor gasoline mileage	<ul style="list-style-type: none"> ● High idle speed ● Fuel pressure out of specification of fuel leakage ● Faulty EGR system ● Defective injector ● Poor performance of TPS, WTS or pressure sensor ● Faulty ECM 	<p>Refer to item "Improper engine idle speed" previously</p> <p>Diagnostic flow chart B-3</p> <p>Diagnostic flow chart B-6</p> <p>Check injector for fuel leakage (See p. 4A-87)</p> <p>See p. 4A-91, 4A-94 or 4A-90</p> <p>See p. 4A-73</p>

SYMPTOM	POSSIBLE CAUSE	INSPECTION
Excessive hydrocarbons (HC) emission (Rich or lean fuel mixture)	<ul style="list-style-type: none"> ● Faulty basic engine parts (Clogged air cleaner, vacuum leaks, faulty ignition system, engine compression, etc..) ● Engine not at normal operating temperature ● Lead contamination of catalytic converter ● Fuel leakage from injector ● Fuel pressure out of specification ● Poor performance of WTS, ATS or pressure sensor ● Faulty ECM 	<p>Check for absence of filler neck restrictor See p. 4A-87 Diagnostic flow chart B-3 See p. 4A-94, 4A-94 or 4A-90 See p. 4A-73</p>
Excessive carbon monoxide (CO) emission (Rich fuel mixture)	<ul style="list-style-type: none"> ● Faulty basic engine parts (Clogged air cleaner, vacuum leaks, faulty ignition system, engine compression, etc..) ● Engine not at normal operating temperature ● Lead contamination of catalytic converter ● Fuel leakage from injector ● Fuel pressure out of specification (High fuel pressure) ● Poor performance of WTS, ATS or pressure sensor ● Faulty ECM 	<p>Check for absence of filler neck restrictor See p. 4A-87 Diagnostic flow chart B-3 See p. 4A-94, 4A-94 or 4A-90 See p. 4A-73</p>
Excessive nitrogen oxides (NOx) emission (Lean fuel mixture)	<ul style="list-style-type: none"> ● Improper ignition timing ● Lead contamination of catalytic converter ● Misrouted vacuum hoses ● Defective EGR system ● Fuel pressure out of specification (Low fuel pressure) ● Poor performance of WTS, ATS or pressure sensor ● Faulty ECM 	<p>See section 8 Check for absence of filler neck restrictor Diagnostic flow chart B-6 Diagnostic flow chart B-3 See p. 4A-94, 4A-94 or 4A-90 See p. 4A-73</p>

B-1 FUEL INJECTOR AND ITS CIRCUIT CHECK (ENGINE NO STARTING)

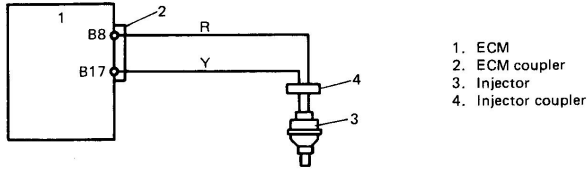

Fig. 4A-85 Injector Circuit

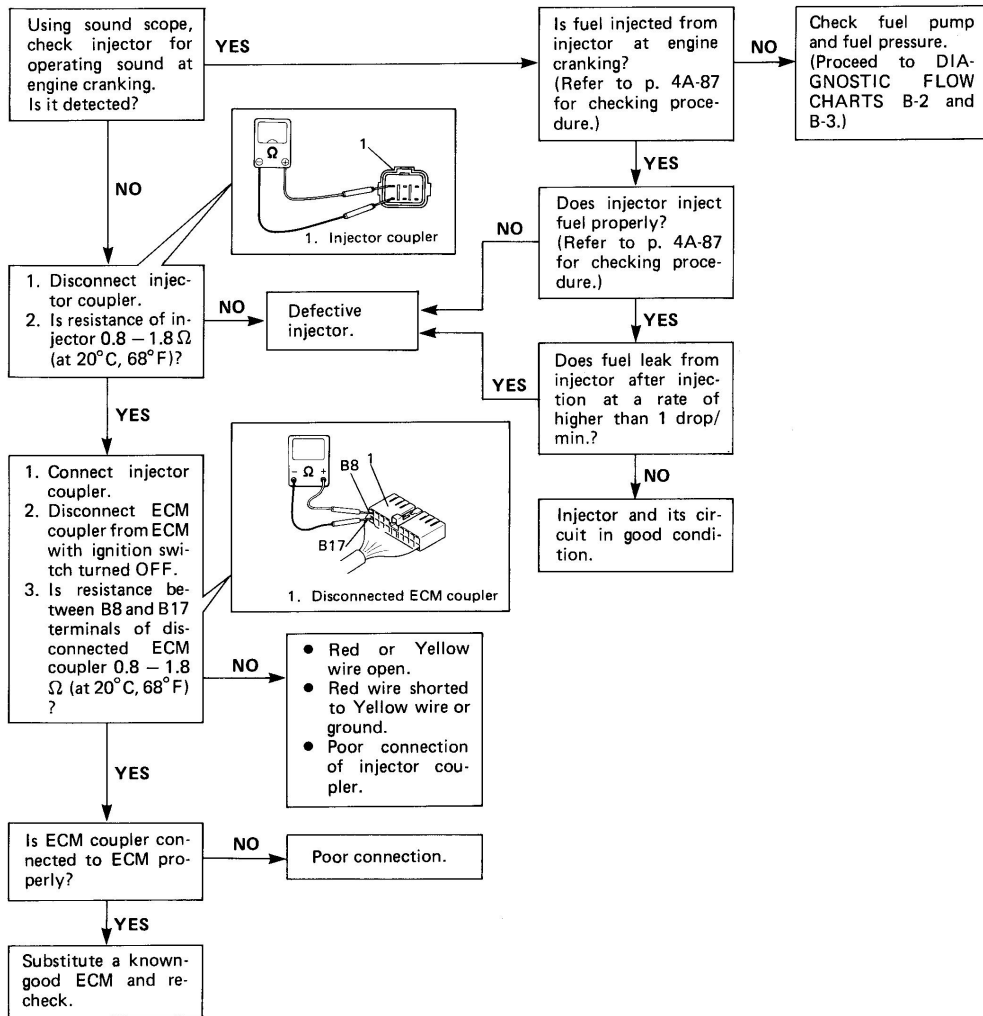

Fig. 4A-86 Diagnostic Flow Chart B-1 For Injector and Its Circuit

B-2 FUEL PUMP CIRCUIT CHECK

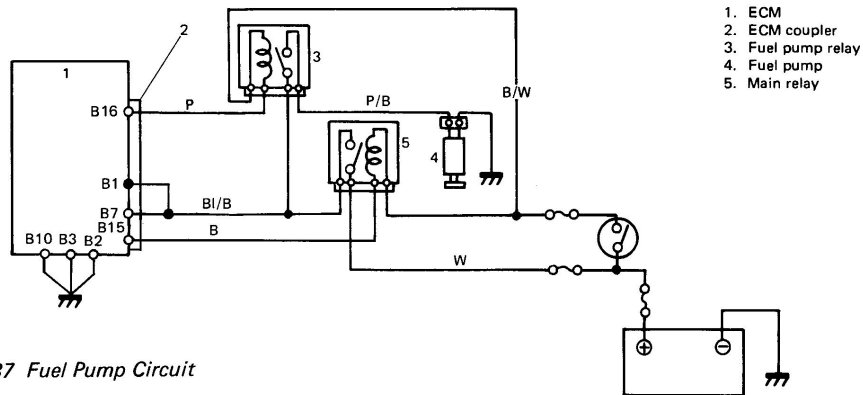

Fig. 4A-87 Fuel Pump Circuit

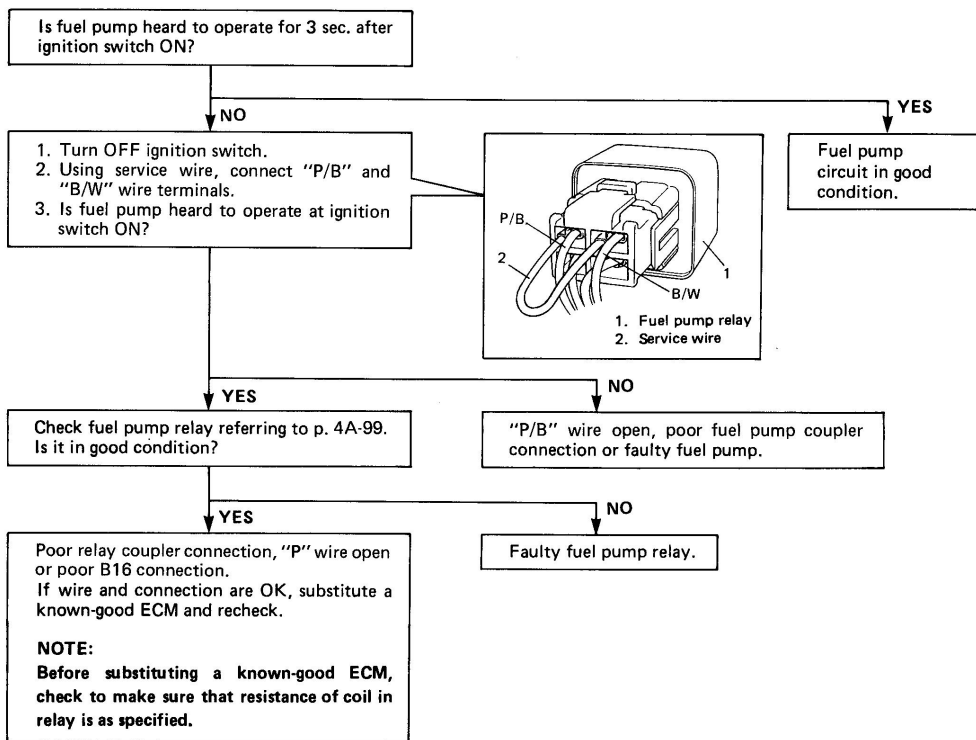

Fig. 4A-88 Diagnostic Flow Chart B-2 For Fuel Pump and Its Circuit Check

B-3 FUEL PRESSURE CHECK

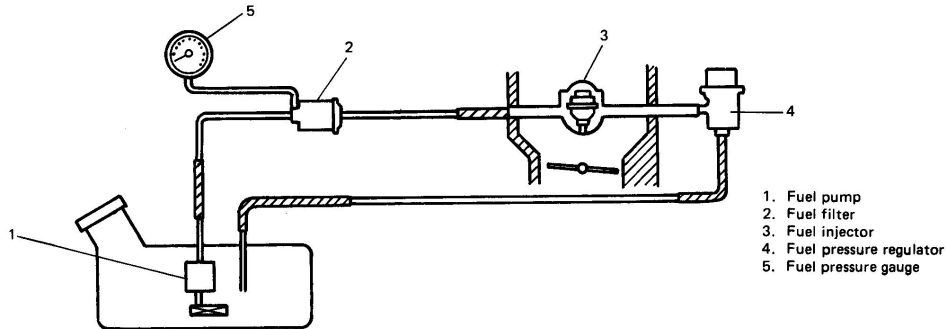

Fig. 4A-89 Fuel Pressure Check

NOTE:

Before using following flow chart, check to make sure that battery voltage is higher than 11V. If battery voltage is low, pressure becomes lower than specification even if fuel pump and line are in good condition.

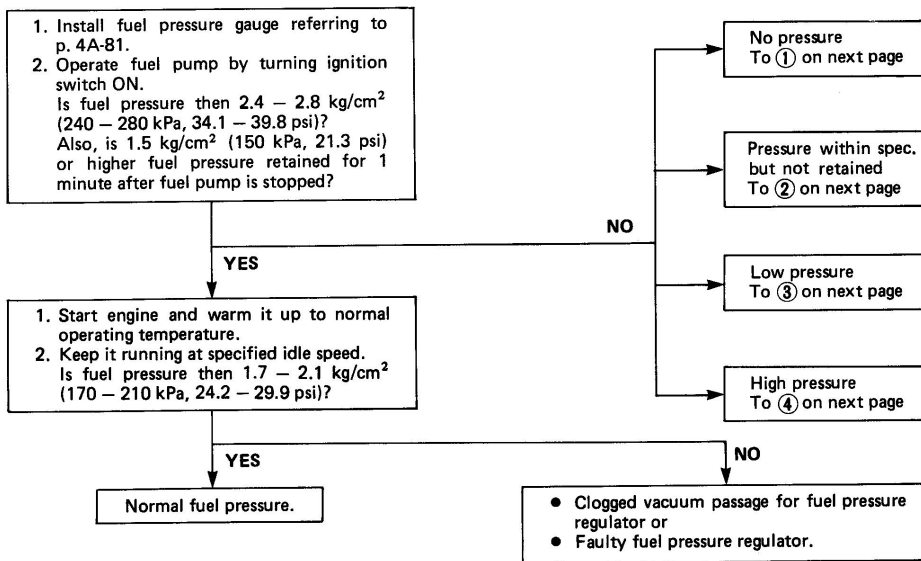

Fig. 4A-90 Diagnostic Flow Chart B-3 For Fuel Pressure Check (1)

B-3 FUEL PRESSURE CHECK (Continued)

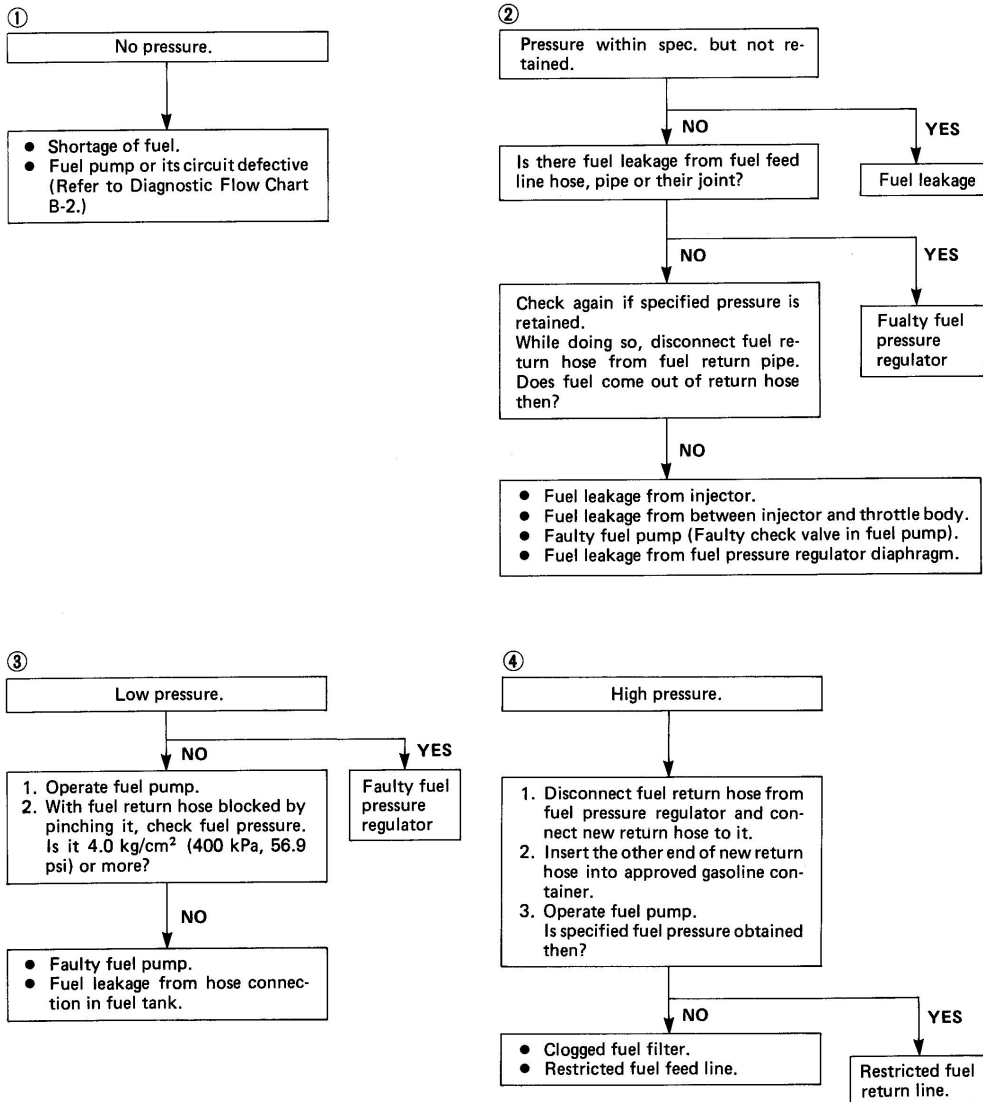
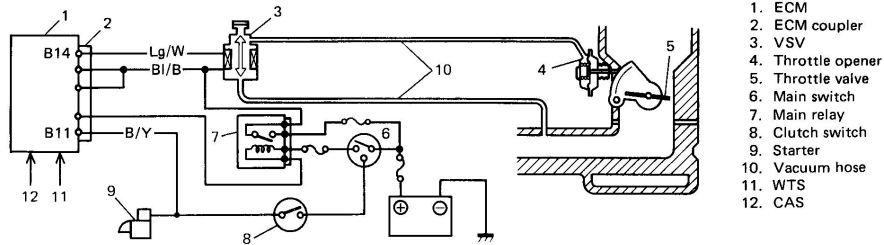

Fig. 4A-91 Diagnostic Flow Chart B-3 For Fuel Pressure Check (2)

B-4 THROTTLE OPENER SYSTEM CHECK



1. ECM
2. ECM coupler
3. VSV
4. Throttle opener
5. Throttle valve
6. Main switch
7. Main relay
8. Clutch switch
9. Starter
10. Vacuum hose
11. WTS
12. CAS

Fig. 4A-92 Throttle Opener System

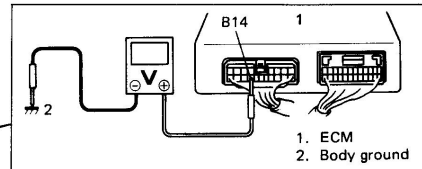
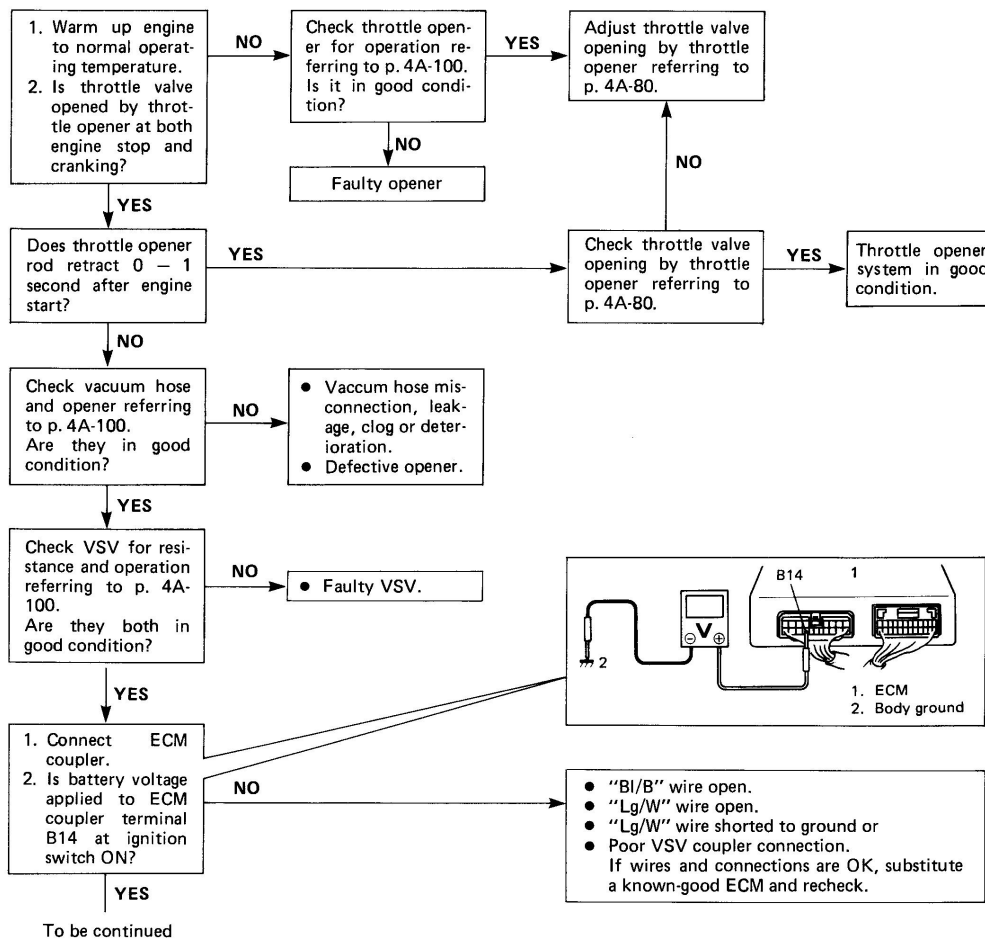

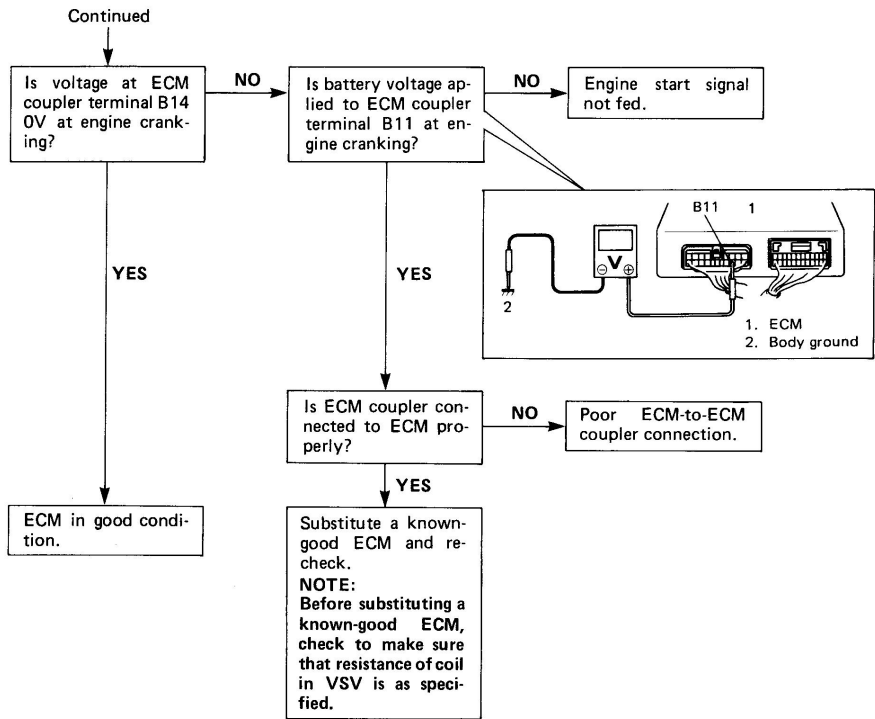

Fig. 4A-93 Diagnostic Flow Chart B-4 For Throttle Opener System

B-5 ISC SOLENOID VALVE CONTROL SYSTEM CHECK

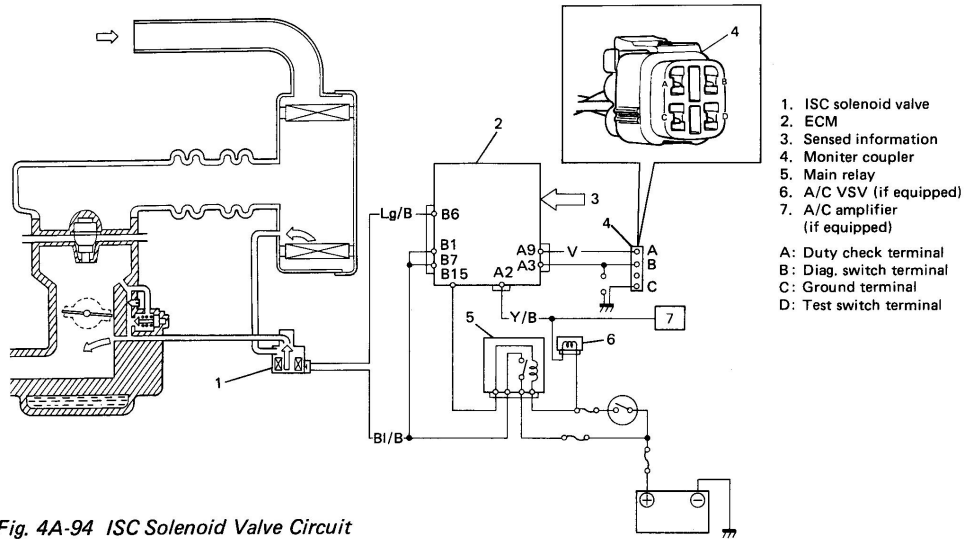

Fig. 4A-94 ISC Solenoid Valve Circuit

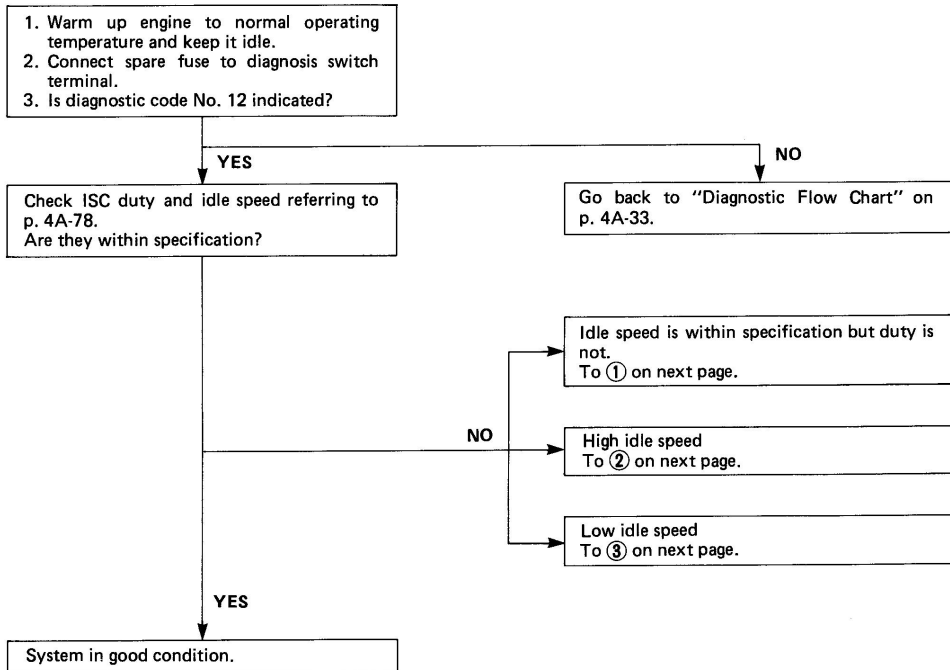

Fig. 4A-95 Diagnostic Flow Chart B-5 For ISC Solenoid Valve Control System (1)

B-5 ISC SOLENOID VALVE CONTROL SYSTEM CHECK (Continued)

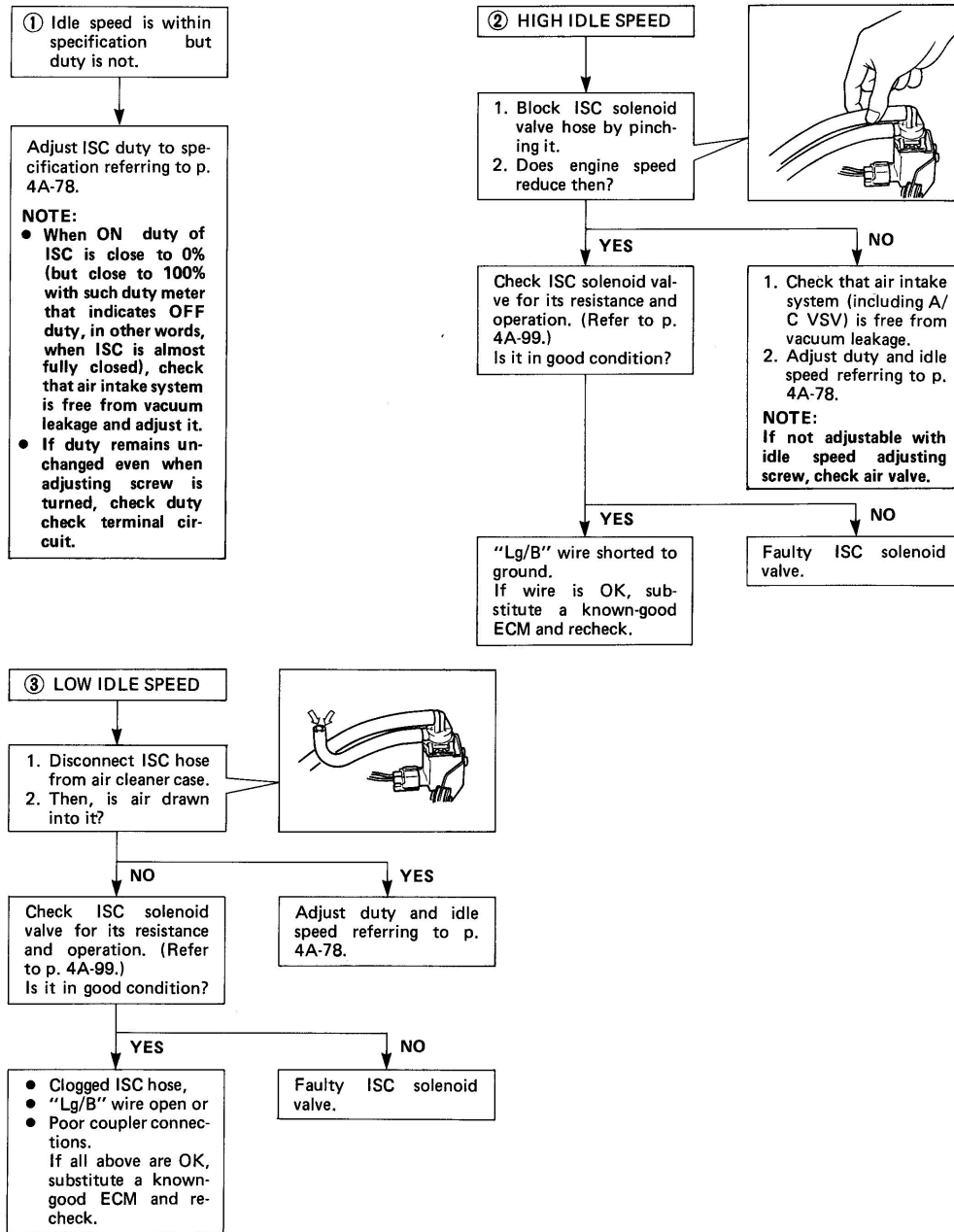

Fig. 4A-96 Diagnostic Flow Chart B-5 For ISC Solenoid Valve Control System (2)

ECM AND ITS CIRCUIT CHECK

ECM and its circuits can be checked at ECM wiring couplers by measuring voltage and resistance.

CAUTION:

ECM cannot be checked by itself. It is strictly prohibited to connect voltmeter or ohmmeter to ECM with couplers disconnected from it.

VOLTAGE CHECK

1. Remove ECM from body.
2. Connect ECM couplers to ECM.
3. Check voltage at each terminal of couplers connected.

NOTE:

As each terminal voltage is affected by the battery voltage, confirm that it is 11V or more when ignition switch is ON.

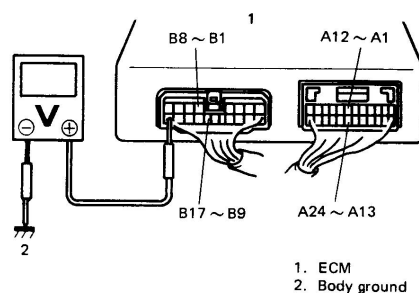

Fig. 4A-99 Checking Voltage

TER-MINAL	CIRCUIT	NORMAL VOLTAGE	CONDITION
A1	Blank	—	—
A2	Air-conditioner circuit (if equipped)	10 – 14V	Ignition switch ON
		0 – 1V	With engine running Air-conditioner ON
A3	Diagnosis switch terminal	10 – 14V	Ignition switch ON
		0V	Ignition switch ON Diagnosis switch terminal grounded (with spare fuse connected to diagnosis switch terminals)
A4	Ground (for California spec. only)	—	—
A5	5th switch (Not for California spec. model)	10 – 14V	Ignition switch ON Gear shift lever at any other position than 5th gear position
		0V	Ignition switch ON Gear shift lever at 5th gear position
A6	Ignition (fail safe) signal	3 – 5V	While engine cranking
		0V	Ignition switch ON
A7	Test switch terminal	10 – 14V	Ignition switch ON
		0V	Ignition switch ON Test switch terminal grounded
A8	Blank	—	—
A9	Duty check terminal	—	—
A10	Blank	—	—

TER-MINAL	CIRCUIT	NORMAL VOLTAGE	CONDITION
A11	Blank	—	—
A12	Ignition output signal	0V	Ignition switch ON
		2 – 4V	While engine cranking
A13	CAS	Indicator deflection repeated between 0V and about 5V	Ignition switch ON Crankshaft turned slowly
A14	Idle switch of TPS	0 – 1V	Ignition switch ON Throttle valve is at idle position (with throttle opener rod drawn in by vacuum pump gauge)
		3 – 5V	Ignition switch ON Throttle valve opens larger than idle position
A15	VSS	Indicator deflection repeated between 0V and 3 – 5V	Ignition switch ON Rear right tire turned slowly with rear left tire locked
A16	REGTS	3.8 – 4.5V	Ignition switch ON Sensor ambient temperature: 20°C (68°F)
A17	ATS	2.2 – 3.0V	Ignition switch ON Sensor ambient temperature: 20°C (68°F)
A18	WTS	0.5 – 0.9V	Ignition switch ON Cooling water temperature: 80°C (176°F)
A19	Oxygen sensor	Refer to Diagnostic Flow Chart for Code No. 13	
A20	Blank	—	—
A21	TPS	0.5 – 1.2V	Ignition switch ON Throttle valve at idle position (with throttle opener rod drawn in by vacuum gauge)
		3.4 – 4.7V	Ignition switch ON Throttle valve at full open position
A22	Pressure sensor	3.6 – 4.4V	Ignition switch ON Barometric pressure: 760 mmHg
A23	Power source of sensors	4.75–5.25V	Ignition switch ON
A24	Ground of sensors	—	—
B1	Power source	10 – 14V	Ignition switch ON
B2	Ground	—	—
B3	Ground	—	—
B4	Blank	—	—
B5	EGR VSV	10 – 14V	Ignition switch ON

4A-74

TER-MINAL	CIRCUIT	NORMAL VOLTAGE	CONDITION
B6	ISC solenoid valve	10 – 14V	Ignition switch ON
B7	Power source	10 – 14V	Ignition switch ON
B8	Injector ⊕	—	—
B9	Power source for back-up circuit	10 – 14V	Ignition switch OFF and ON
B10	Ground	—	—
B11	Engine start switch (Engine start signal)	6 – 10V	While engine cranking
		0V	Other than above
B12	Clutch switch	0V	Ignition switch ON Clutch pedal depressed
		10 – 14V	Ignition switch ON Clutch pedal released
B13	"CHECK ENGINE" light	0 – 1V	Ignition switch ON
		10 – 14V	When engine running
B14	Throttle opener VSV	10 – 14V	Ignition switch ON
B15	Main relay ground	0 – 2V	Ignition switch ON
B16	Fuel pump relay ground	0 – 4V	For 3 sec. after ignition switch ON
		10 – 14V	When over 3 sec. after ignition switch ON
B17	Injector ⊖	—	—

RESISTANCE CHECK

1. Disconnect ECM couplers from ECM with ignition switch OFF.

CAUTION:

Never touch terminals of ECM itself or connect voltmeter or ohmmeter.

2. Check resistance between each pair of terminals disconnected couplers as listed in following table.

CAUTION:

- Be sure to connect ohmmeter probe from wire harness side of coupler.
- Be sure to turn OFF ignition switch for this check.
- Resistance in table represents that when parts temperature is 20°C (68°F).

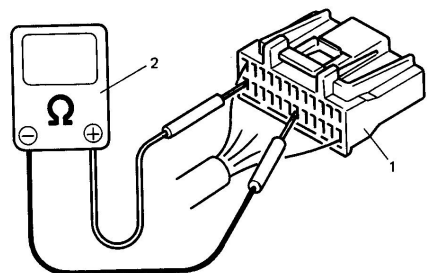

1. ECM coupler disconnected
2. Ohmmeter

Fig. 4A-100 Checking Resistance

TERMINALS	CIRCUIT	STANDARD RESISTANCE	CONDITION
A3 – Body ground	Diagnosis switch terminal	∞ (infinity)	_____
A4 – Body ground (California spec. model only)	ECM ground	Continuity	_____
A5 – Body ground (Not for California spec. model)	5th switch	∞ (infinity)	Gear shift lever at any other position than 5th gear position
		Continuity	Gear shift lever at 5th gear position
A7 – Body ground	Test switch terminal	∞ (infinity)	_____
A9 – Body ground	Duty check terminal	∞ (infinity)	_____
A14 – A24	Idle switch	0 – 500 Ω	Throttle valve is at idle position
		∞ (infinity)	Throttle valve opens larger than idle position
A15 – Body ground	VSS	Ohmmeter indicator deflects between 0 and ∞	Rear right tire turned slowly with rear left tire locked
A16 – A24 (California spec. model only)	REGTS	214 – 313.8 k Ω	Sensor ambient temp. 20°C (68°F)
A17 – A24	ATS	2.28 – 2.87 k Ω	Sensor ambient temp. 20°C (68°F)
A18 – A24	WTS	0.29 – 0.35 k Ω	Engine cooling water temp. 80°C (176°F)
A21 – A24	TPS	0 – 2 k Ω	Throttle valve at idle position
		2.0 – 6.5 k Ω	Throttle valve at full open position
			with PS coupler disconnected
B5 – B1	EGR VSV	33 – 39 Ω	_____
B6 – B1	ISC solenoid valve	30 – 33 Ω	_____
B8 – B17	Fuel injector	0.8 – 1.8 Ω	_____
B12 – Body ground	Clutch switch	Continuity	Clutch pedal depressed
		∞ (infinity)	Clutch pedal released
B14 – B1	Throttle opener VSV	33 – 39 Ω	_____
B15 – B16	Main and fuel pump relay	124 – 153 Ω	_____

ON VEHICLE SERVICE

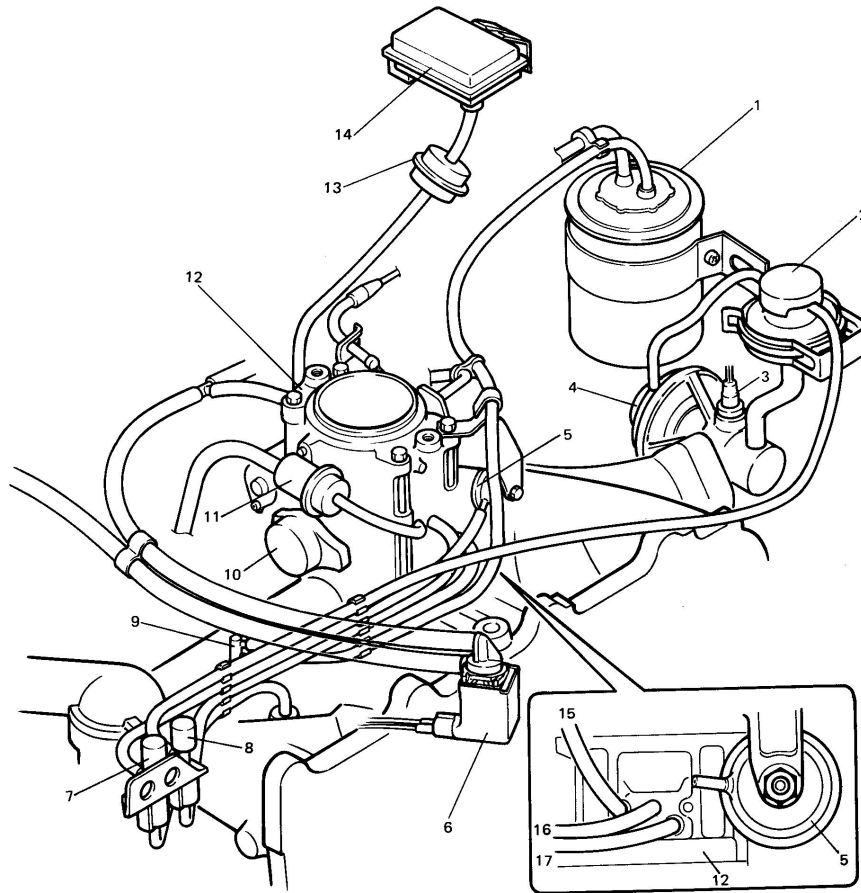

- | | |
|--|--------------------------------|
| 1. Charcoal canister | 10. TPS |
| 2. EGR modulator | 11. Fuel pressure regulator |
| 3. REGTS (California spec. model only) | 12. Throttle body |
| 4. EGR valve | 13. Filter |
| 5. Throttle opener | 14. Pressure sensor |
| 6. ISC solenoid valve | 15. To fuel pressure regulator |
| 7. VSV for throttle opener | 16. To EGR VSV |
| 8. VSV for EGR valve | 17. To BVS |
| 9. BVS | |

Fig. 4A-101 Vacuum Hose Routing

GENERAL

When hoses are disconnected and system's component is removed for service, reinstall component properly, and route and connect hoses correctly after service. Refer to Fig. 4A-101 or Vehicle Emission Control Information Label for proper routing of hoses.

ACCELERATOR CABLE ADJUSTMENT

Check accelerator cable for play and adjust if necessary. Cable play should be within specification when accelerator pedal is released and engine is not running.

If not within specification, adjust by loosening lock nut. Be sure to tighten lock nut securely after adjustment.

Accelerator cable play	10 – 15 mm (0.4 – 0.6 in.)
------------------------	-------------------------------

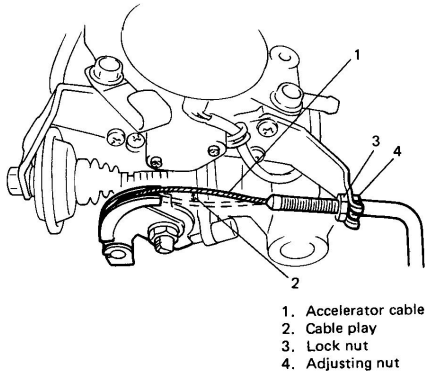

Fig. 4A-102 Accelerator Cable Play

Cable play should be 3 – 5 mm (0.12 – 0.20 in.) when throttle opener rod is pushed back by hand (i.e., throttle valve is at idle position).

IDLE SPEED/ISC DUTY ADJUSTMENT (INCLUDING A/C VSV ADJUSTMENT)

Before idle speed check and adjustment, make sure of the following.

- Lead wires and hoses of Electronic Fuel Injection and engine emission control systems are connected securely.
- Accelerator cable has some play, that is, it is not tight.
- Valve lash is checked and adjusted according to maintenance schedule.
- Ignition timing is within specification.
- All accessories (wipers, heater, lights, A/C, etc.) are out of service.
- Air cleaner has been properly installed and is in good condition.

After above items are all confirmed, check idle speed and ISC duty as follows.

NOTE:

Before starting engine, place transmission gear shift lever in "Neutral", and set parking brake and block drive wheels.

1. Warm up engine to normal operating temperature.
2. Connect spare fuse to diagnosis switch terminal in fuse box and make sure that "CHECK ENGINE" light indicate diagnostic code No. 12.

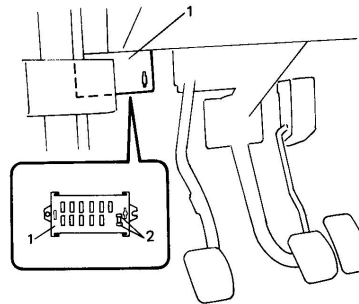

1. Fuse box
2. Diagnosis switch terminal

Fig. 4A-103 Grounding Diag. Switch Terminal

3. Stop engine and connect duty meter between duty check terminal and ground terminal of monitor coupler.
The monitor coupler is located beside battery.

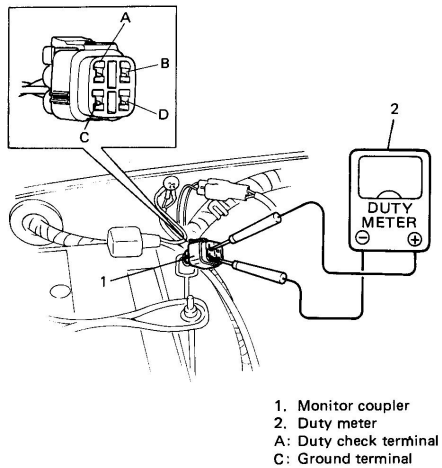
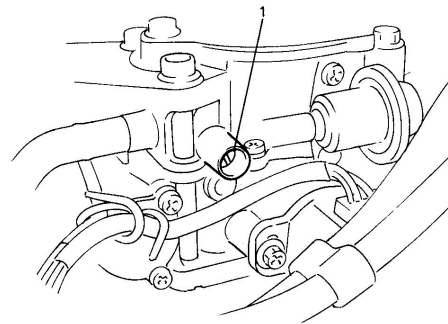

Fig. 4A-104 Connecting Duty Meter

4. Set tachometer.
5. Turn ON ignition switch and wait for 5 seconds. Then restart engine and run it at 2,000 r/min. for 5 minutes to warm it up completely and let it slow down to idle speed.
6. Check ISC duty and idle speed. If duty and/or idle speed is out of specifications, adjust it by turning idle speed adjusting screw.

Engine idle speed	800 ± 50 r/min.
ISC duty at specified idle speed	50%



1. Idle speed adjusting screw

Fig. 4A-105 Idle Speed Adjusting Screw

7. Upon completion of adjustment, install adjusting screw cap to throttle body.
8. This step is for checking and/or adjusting engine idle speed and ISC duty when A/C is working.
With vehicles without A/C, advance to steps 9 and 10. With A/C equipped ones, follow procedure described below.
1) Turn A/C switch ON and set heater blower switch to low speed position.
2) Check to ensure that ISC duty and idle speed are within below specification.

Engine idle speed with A/C ON	1,000 ± 50 r/min.
ISC duty at specified idle speed	50%

- 3) If it is not within specified range, adjust it by turning adjusting screw of A/C VSV.

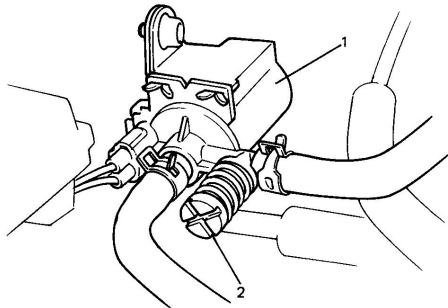

1. A/C VSV
2. Adjusting screw

Fig. 4A-106 Adjusting Screw of A/C VSV

9. Disconnect spare fuse from diag. switch terminal.
10. Install cap to monitor coupler.

THROTTLE OPENER ADJUSTMENT

NOTE:

Before starting engine, place transmission gear shift lever in "Neutral", and set parking brake and block drive wheels.

1. Turn ignition switch ON and leave it for 5 sec. Run engine at 2000 r/min. for 5 min. after warming up and let it slow down to idle speed.
2. Check to make sure that no electric load is applied to engine.
3. Disconnect vacuum hose from throttle opener and put blind plug in disconnected vacuum hose.
Check that engine speed is within specification then.

Engine speed while opener operating	2200 ± 50 r/min.
-------------------------------------	------------------

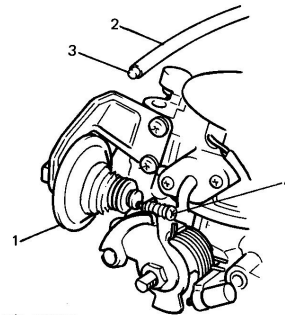

1. Throttle opener
2. Vacuum hose
3. Blind plug
4. Opener adjusting screw

Fig. 4A-107 Checking and Adjusting Engine Speed for Opener

4. If engine speed is found out of specification in above check, adjust it to specification by turning throttle opener adjusting screw.
5. Upon completion of adjustment, connect vacuum hose to opener securely.

AIR AND FUEL DELIVERY SYSTEM

FUEL PRESSURE INSPECTION

1. Relieve fuel pressure in fuel feed line referring to p. 4-2.
2. Hoist vehicle.
3. Remove plug bolt on fuel filter union bolt and connect special tool (fuel pressure gauge set) to fuel filter inlet union bolt.

CAUTION:

A small amount of fuel may be released after fuel line is disconnected.

In order to reduce chance of personal injury, cover fitting to be disconnected with a shop cloth. Place that cloth in an approved container when disconnection is completed.

Fuel pressure gauge set (09912-58412)

- | | |
|---------------|----------------------------|
| 1. Gauge | 5. Filter inlet union bolt |
| 2. Hose | 6. Fuel filter |
| 3. Union bolt | |
| 4. Gasket | |

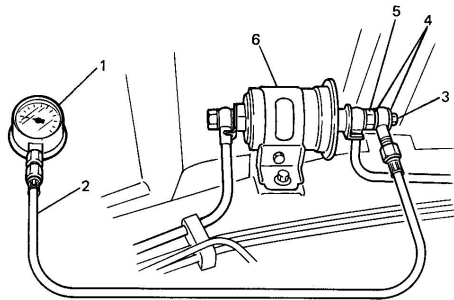
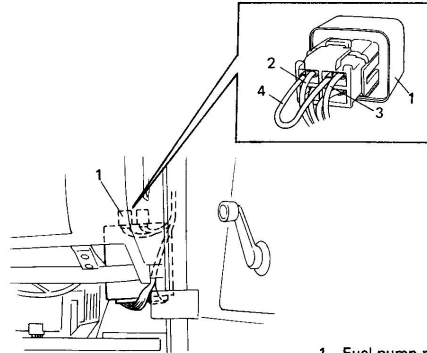

Fig. 4A-108 Connecting Fuel Pressure Gauge

4. Check that battery voltage is above 11V.

5. To operate fuel pump, connect Pink/Black and Black/White wire terminals by using service wire and turn ignition switch ON. Measure fuel pressure.



- | |
|--------------------|
| 1. Fuel pump relay |
| 2. Pink/Black |
| 3. Black/White |
| 4. Service wire |

Fig. 4A-109 Operating Fuel Pump

6. Measure fuel pressure under each of following conditions.

CONDITION	FUEL PRESSURE
With fuel pump operating and engine at stop	2.4 – 2.8 kg/cm ² 240 – 280 kPa 34.1 – 39.8 psi
For 1 min. after fuel pump stop (Pressure reduces as time passes)	Over 1.5 kg/cm ² 150 kPa 21.3 psi

7. Disconnect service wire.
8. Start engine and warm it up to normal operating temperature.
Measure fuel pressure at specified idle speed.

CONDITION	FUEL PRESSURE
At specified idle speed	1.7 – 2.1 kg/cm ² 170 – 210 kPa 24.2 – 29.9 psi

If measured pressure doesn't satisfy specification, refer to "Diagnostic Flow Chart B-3" and check each possibly defective part. Replace if found defective.

- After checking fuel pressure, remove fuel pressure gauge.

CAUTION:

As fuel feed line is still under high fuel pressure, make sure to release fuel pressure according to following procedures.

- Place fuel container under fuel filter.
- Cover union bolt of gauge with rag and loosen union bolt slowly to release fuel pressure gradually.

- Install plug bolt to fuel filter inlet union bolt. Use new gasket. Tighten it to specified torque.
- With engine "OFF" and ignition switch "ON", check for fuel leaks.

FUEL PUMP

On Vehicle Inspection

CAUTION:

When fuel filler cap is removed in any procedure, work must be done with no smoking, in a well-ventilated area and away from any open flames.

- Remove filler cap and turn ON ignition switch. Then fuel pump operating sound should be heard from fuel filler for about 3 seconds and stop. Be sure to reinstall fuel filler cap after checking.

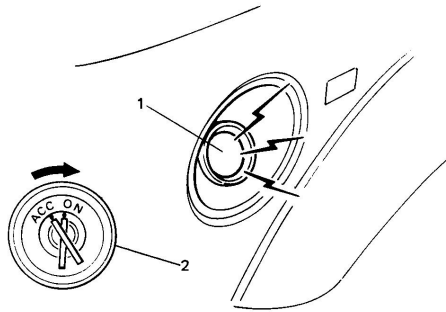

1. Fuel filler
2. Ignition switch

Fig. 4A-110 Checking Fuel Pump

4A-82

- If above check result is not satisfactory, advance to "Diagnostic Flow Chart B-2".
- Fuel pressure should be felt at fuel return hose for 3 seconds after ignition switch ON.

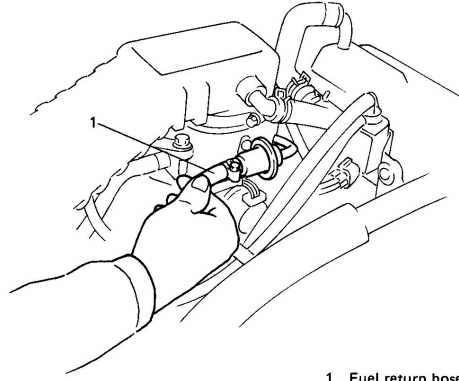

1. Fuel return hose

Fig. 4A-111 Checking Fuel Pressure

If fuel pressure is not felt, advance to "Diagnostic Flow Chart B-3".

Removal

- Remove fuel tank from body according to procedure described in section 4 and remove fuel pump from fuel tank.

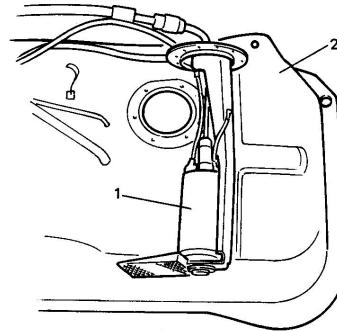

1. Fuel pump
2. Fuel tank

Fig. 4A-112 Removing Fuel Pump

Inspection

Check fuel pump filter for evidence of dirt and contamination. If present, clean and check for presence of dirt in fuel tank.

Installation

1. Install fuel pump to its bracket.
2. Install fuel pump to fuel tank and then install fuel tank to body according to procedure described in section 4.

THROTTLE BODY

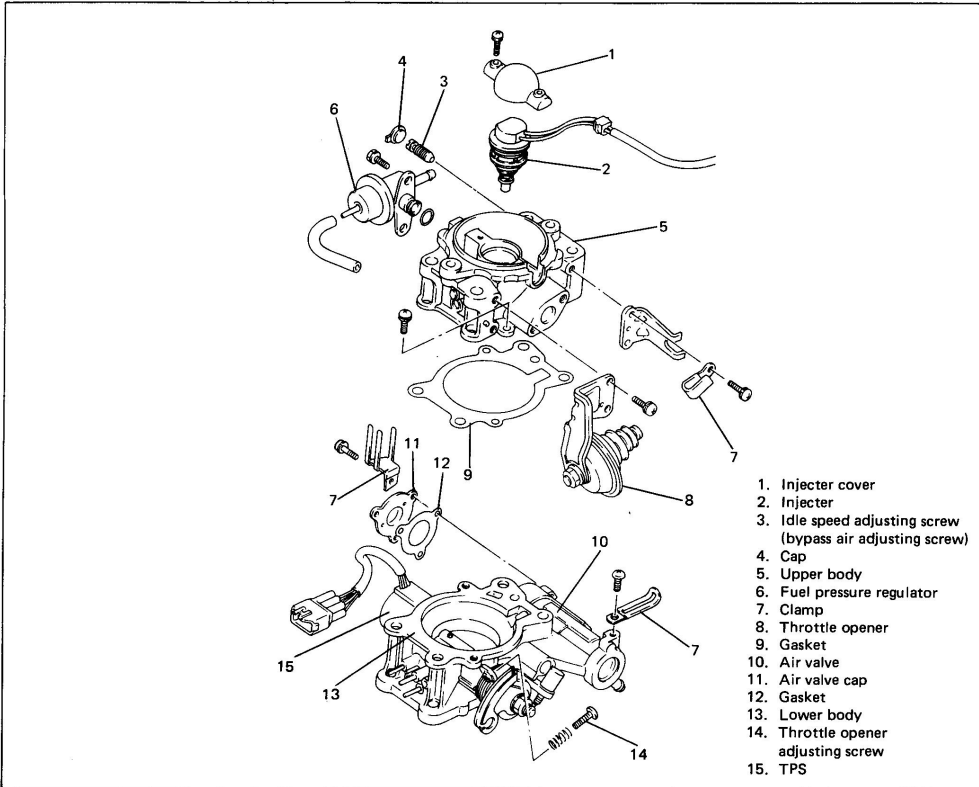

Fig. 4A-113 Throttle Body Parts Identification

On Vehicle Inspection

- Check that the throttle valve lever moves smoothly.
- Vacuum passage inspection
With fingers placed against vacuum nozzles (2 or 3 pcs), increase engine speed a little and check that vacuum is applied.

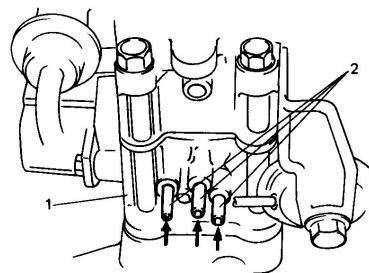

Fig. 4A-114 Checking Vacuum Passage

- Air valve inspection

This is an easy on-vehicle check. For further complete check, remove throttle body and use checking procedure as shown in Fig. 4A-116.

1. Remove air valve cap with engine stopped when engine is cold (engine cooling water temperature is 60°C, 140°F or lower) and checking procedure as shown in Fig. 4A-116.
2. Reinstall air valve cap and warm up engine to its normal operating temperature (engine cooling water temperature is 70°C, 158°F or higher).
Then remove air valve cap again with engine stopped and check visually that air valve is closed.

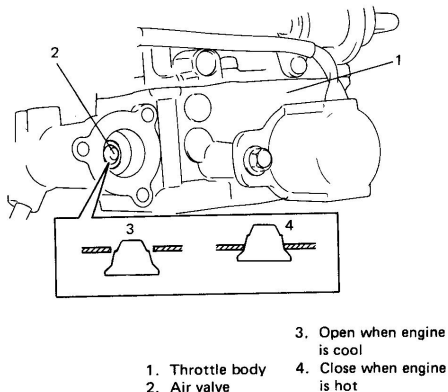

Fig. 4A-115 Inspecting Air Valve

3. Upon completion of checking, be sure to use new gasket when reinstalling air valve cap.

Removal

1. Relieve fuel pressure in fuel feed line referring to p. 3-3.
2. Disconnect negative cable at battery.
3. Drain engine cooling water.
4. Remove air intake case from throttle body and air cleaner case.
5. Disconnect fuel feed pipe from throttle body.
6. Disconnect fuel return hose from fuel pressure regulator.
7. Disconnect accelerator cable from throttle body.
8. Disconnect vacuum hoses from throttle body.
9. Disconnect cooling water hose from throttle body.
10. Disconnect fuel injector and TPS coupler.
11. Remove throttle body from intake manifold.

Inspection

1. Remove air valve cap.
2. Immerse air valve of throttle body in water as shown below. Check visually that air valve closes gradually as water temperature rises and closes fully at higher than about 70°C, 158°F.

NOTE:

- Be very careful to prevent water from entering throttle body bore.
- Be very careful never to put throttle body parts except air valve thermo wax in water or expose them to water splash.

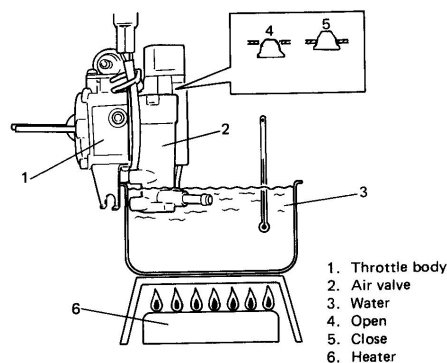

Fig. 4A-116 Inspecting Air Valve

Disassembly

NOTE:

- Be sure to replace gaskets as well as worn or damaged parts.
- While disassembling and assembling throttle body, use special care not to deform levers on throttle valve shaft or cause damage to any other parts.

1. Remove injector from throttle body according to procedure described in p. 4A-88.
2. Remove TPS.
3. Remove fuel pressure regulator from throttle body.
4. After removing screws, separate upper and lower bodies.

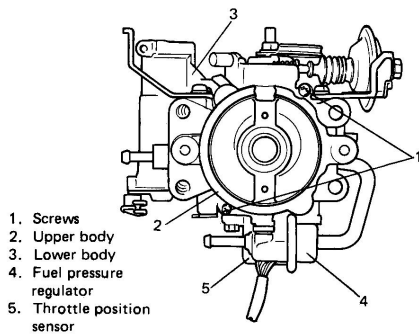

Fig. 4A-117 Disassembling Throttle Body

Cleaning

Clean below passages and fuel injector chamber by blowing compressed air.

NOTE:

- The TPS, fuel pressure regulator, fuel injector, air valve, throttle opener or other components containing rubber must not be placed in a solvent or cleaner bath. A chemical reaction will cause these parts to swell, harden or get distorted.
- Don't put drills or wires into passages for cleaning. It causes damages in passages.

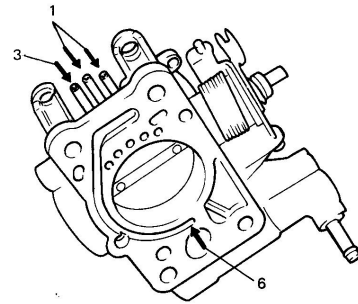
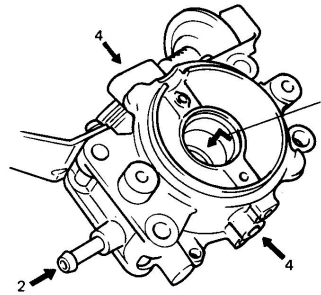

- | | |
|---|-----------------------------|
| 1. Vacuum passage | 4. Fuel passage |
| 2. ISC solenoid valve passage | 5. Injector chamber passage |
| 3. Vacuum passage for fuel pressure regulator | 6. Air induction passage |

Fig. 4A-118 Cleaning Passage

Assembly

1. Install new gasket to lower body.

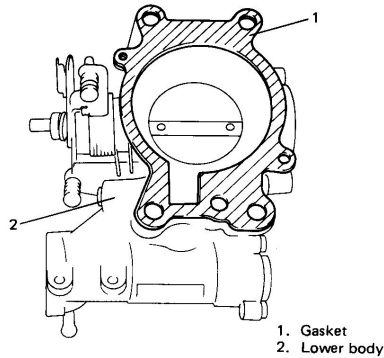

Fig. 4A-119 Installing Gasket

2. Install upper body on gasket, using care not to cause gasket to slip out of place.
3. Tighten screws indicated by "1" in Fig. 4A-117 to specified torque.

Tightening torque of screw	N-m	kg-m	lb-ft
	3.5	0.35	2.5

4. Install fuel pressure regulator according to procedure described in p. 4A-89.
5. Install fuel injector according to procedure described on p. 4A-88.
6. Install throttle position sensor according to procedure described on p. 4A-93.
7. Clamp wire harness securely.

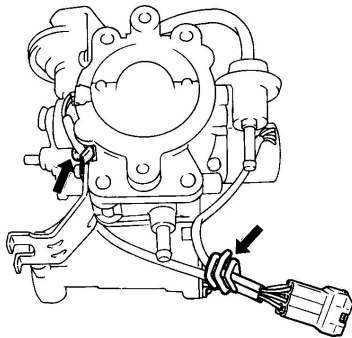

Fig. 4A-120 Clamping Wire Harness

Installation

1. Clean mating surfaces and install throttle body gasket to intake manifold. Use new gasket.

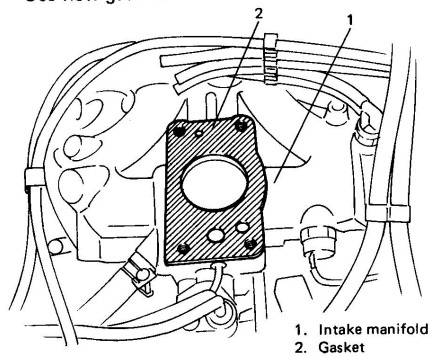

Fig. 4A-121 Gasket Installation

4A-86

2. Install throttle body to intake manifold and tighten bolts to specified torque.

Tightening torque for throttle body bolts	N-m	kg-m	lb-ft
	18 - 28	1.8 - 2.8	13.5 - 20.0

3. Connect fuel injector and TPS coupler.
4. Connect cooling water hose to throttle body.
5. Connect vacuum hoses to throttle body.

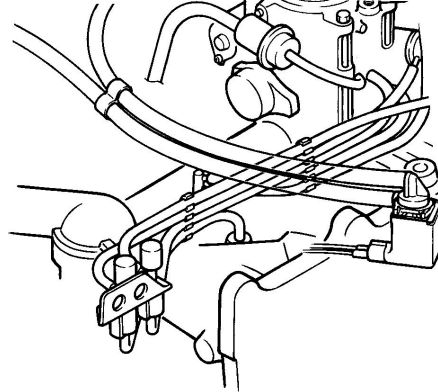

Fig. 4A-122 Connecting Vacuum Hoses

6. Connect accelerator cable to throttle body. Adjust the cable play to specification according to procedure described in p. 4A-78.
7. Connect fuel return hose to fuel pressure regulator and clamp it securely.
8. Connect fuel feed pipe to throttle body after applying thin coat of spindle oil or gasoline to O ring. Use a new O ring. Tighten pipe bolts to specified torque.

Tightening torque for fuel feed pipe bolts	N-m	kg-m	lb-ft
	8 - 12	0.8 - 1.2	6.0 - 8.5

9. Refill engine cooling system.
10. Connect negative cable at battery.
11. With engine "OFF" and ignition switch "ON", check for fuel leaks around fuel line connection.
12. Install air intake case seal and joint to throttle body.

13. Install air intake case to throttle body and air cleaner case.
14. Upon completion of installation, start engine and check for fuel leaks and engine cooling water leaks.

FUEL INJECTOR

On Vehicle Inspection

1. With battery negative cable disconnected, disconnect injector coupler.
2. Connect ohmmeter to each injector terminal and measure resistance.

Resistance of injector	0.8 – 1.8 Ω at 20° C (68° F)
------------------------	--

If resistance is out of specification, replace fuel injector.

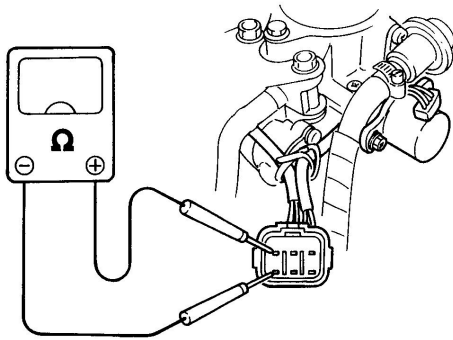

Fig. 4A-123 Checking Resistance of Fuel Injector

3. Connect injector coupler.
4. Remove air intake case.
5. Connect battery negative cable.
6. Make sure that fuel pressure is felt at fuel return hose for 3 seconds after ignition switch ON.
7. Check that fuel is injected out in conical shape from fuel injector when cranking engine or running engine.

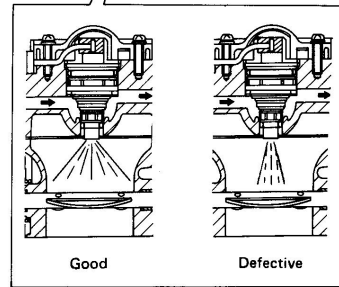
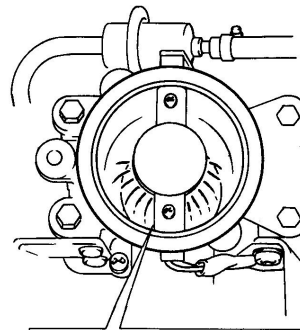

Fig. 4A-124 Checking Fuel Injection

If no fuel is injected, check wiring harness for continuity and couplers for proper connection referring to "Diagnostic Flow Chart B-1". If fuel is not injected in conical shape, replace injector.

8. Check injector for fuel leakage after injection is stopped (i.e., after cranking or engine stop). Replace if leakage exists.

Fuel leakage	Less than 1 drop/min.
--------------	-----------------------

9. Install air intake case.

Removal

1. Relieve fuel pressure in fuel feed line referring to p. 3-3.
2. Disconnect battery negative cable at battery.
3. Remove air intake case and case joint.
4. Remove fuel feed pipe clamp from intake manifold and disconnect fuel feed pipe from throttle body.
5. Remove injector cover.
6. Disconnect injector coupler, release its wire harness from clamp and remove its grommet from throttle body.
7. Place some cloth over injector and hand on top of it. Using air gun, blow about 5 kg/cm² (500 kPa, 71.1 psi) or less compressed air into fuel inlet port of throttle body, and injector can be removed.

WARNING:

Be precise about pressure of compressed air. Blowing air under excessively high pressure may force injector jump out and cause damage not only to injector itself but also to other parts.

NOTE:

Use care when handling fuel injector especially not to damage injector-to-wire harness connection and its needle.

Also, because injector is an electrical component, it should not be immersed in any type of liquid solvent or cleaner, as damage may occur.

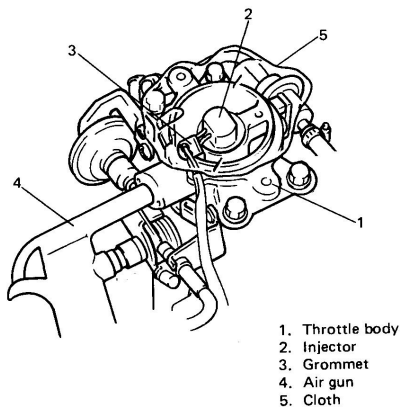
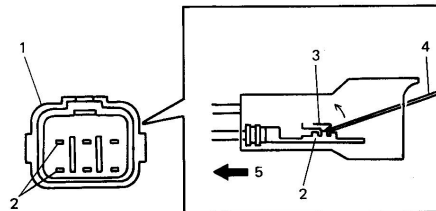

Fig. 4A-125 Removing Injector

4A-88

8. Pull out fuel injector wire harness terminals from coupler after unlocking terminal lock.



1. Coupler
2. Fuel injector terminals
3. Terminal lock
4. Thin wire
5. Pull out while unlocking

Fig. 4A-126 Removing Terminals

Inspection

Check fuel injector filter for evidence of dirt and contamination. If present, clean and check for presence of dirt in fuel lines and fuel tank.

Installation

1. Make sure that injector O rings are free from any damage and deterioration.
 2. Apply thin coat of spindle oil or gasoline to O rings and then install injector to throttle body.
- Make sure to fit injector wire harness into groove in throttle body securely.

NOTE:

Do not apply force to wire harness-to-injector connection.

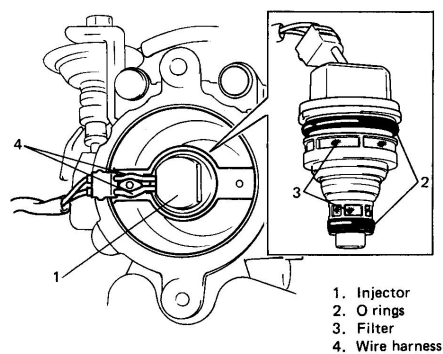

Fig. 4A-127 Installing Injector

3. Install injector cover.

Use new screws and tighten them to specified torque.

Tightening torque for injector cover screw	N·m	kg·m	lb·ft
	2	0.2	1.4

4. Connect fuel feed pipe to throttle body after applying thin coat of engine oil to O ring.
5. Connect battery negative cable.
6. Repeat ignition switch ON for 3 sec. and OFF until fuel pressure is felt at fuel return hose and check that no fuel leaks from where fuel feed pipe is connected and where injector is installed.
7. Install air intake case and joint.
8. Connect fuel injector terminals into coupler, check to make sure that they are locked securely.

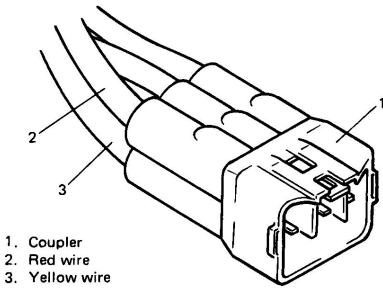

1. Coupler
2. Red wire
3. Yellow wire

Fig. 4A-128 Connecting Fuel Injector Wires

FUEL PRESSURE REGULATOR

Removal

1. Relieve fuel pressure in the fuel feed line referring to p. 3-3.
2. Disconnect battery negative cable from battery.
3. Disconnect fuel return hose and vacuum hose from fuel pressure regulator.
4. Remove fuel pressure regulator from throttle body.

CAUTION:

A small amount of fuel may be released when regulator is removed. Cover its hole with shop cloth.

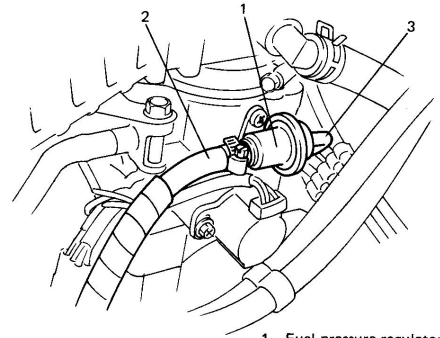

1. Fuel pressure regulator
2. Fuel return hose
3. Vacuum hose

Fig. 4A-129 Fuel Pressure Regulator Removal

Installation

For installation, reverse removal procedure and note following precautions.

- Use new O ring.
- Apply thin coat of spindle oil or gasoline to O ring to facilitate installation.

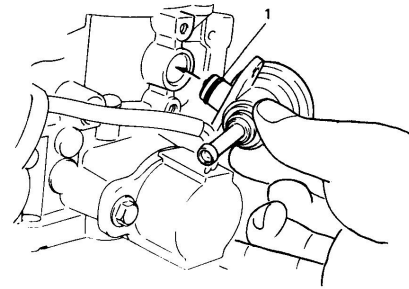

1. O ring

Fig. 4A-130 Installing Fuel Pressure Regulator

- Tighten fuel pressure regulator screws securely to following specified torque.

Tightening torque for fuel pressure regulator screw	N·m	kg·m	lb·ft
	3.5	0.35	2.5

- Upon completion of installation, check that no fuel leakage exists with applying fuel pressure to fuel feed line.

ELECTRONIC CONTROL SYSTEM

ELECTRONIC CONTROL MODULE (ECM)

CAUTION:

As ECM consists of precision parts, be careful not to expose it to excessive shock.

Removal

1. Disconnect battery negative cable from battery.
2. Remove fuel pump relay and main relay from ECM.
3. Disconnect couplers from ECM while releasing coupler lock.
4. Remove ECM after loosening three screws.

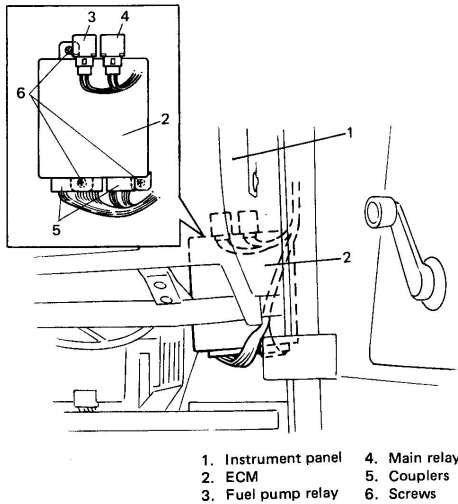

Fig. 4A-131 Removing ECM

Installation

1. Install ECM.
2. Connect couplers to ECM securely.
3. Install fuel pump relay and main relay to ECM.
4. Connect battery negative cable to battery.

PRESSURE SENSOR (PS)

Output Voltage Check

1. Remove package tray under ECM.
 2. With coupler connected to ECM, connect digital type voltmeter as shown below and check that ECM supply voltage 4.75 – 5.25V is applied to coupler terminal A23.
 3. Check output voltage at coupler terminal A22.
- Note that it varies with atmospheric pressure and altitude.
- Also, start engine, if it can, and check if output voltage varies.

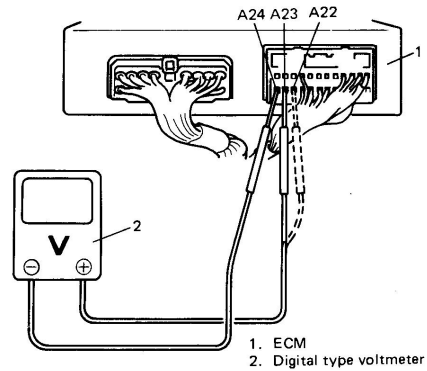

Fig. 4A-132 Checking Pressure Sensor

Output voltage (ECM supply voltage 4.75 – 5.25V)

ALTITUDE		BAROMETRIC PRESSURE (mmHg)	OUTPUT VOLTAGE (V)
(ft)	(m)		
0	0	760	3.6 – 4.4
1 000	305	733	3.5 – 4.2
2 000	610	707	3.4 – 4.1
3 000	914	682	3.2 – 4.0
4 000	1 219	658	3.1 – 3.8
5 000	1 524	634	3.0 – 3.7
6 000	1 829	611	2.9 – 3.6
7 000	2 133	589	2.8 – 3.4
8 000	2 438	567	2.7 – 3.3
9 000	2 743	546	2.6 – 3.2
10 000	3 048	526	2.5 – 3.1

NOTE:

Note that atmospheric pressure varies depending on weather conditions as well as altitude. Take that into consideration when performing above check.

If check result is not satisfactory in previous step 2 or 3, check pressure sensor and its circuit according to Code No. 31 or 32 Diagnostic Flow Chart.

NOTE:

If output voltage does not vary when engine is started, it is possible that vacuum hose and/or filter are clogged. Clean them.

Another possibility is that filter in pressure sensor is clogged from freezing. If it is suspected, leave it at room temperature (20°C, 68°F) for a while and recheck.

4. Upon completion of checking, install package tray.

Pressure Sensor Individual Check

1. Disconnect pressure sensor vacuum hose from filter.
2. Disconnect pressure sensor coupler.
3. Remove pressure sensor.
4. Arrange 3 new 1.5V batteries in series and connect its positive terminal to "Vin" terminal of coupler and negative terminal to "Ground" terminal. Then check voltage between "Vout" and "Ground".

Also, check if voltage reduces when vacuum is applied up to 40 cmHg by using vacuum pump.

CAUTION:

As connection to wrong terminal will cause damage to pressure sensor, make absolutely sure to connect properly as shown below.

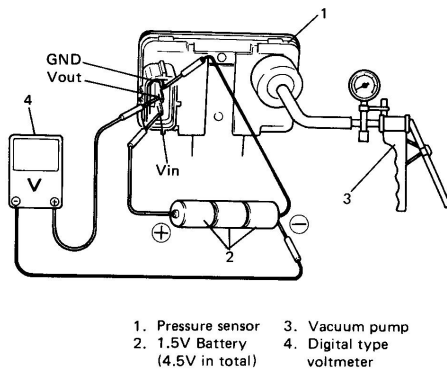

Fig. 4A-133 Checking Pressure Sensor

Output voltage (Vin voltage 4.5V)

ALTITUDE		BAROMETRIC PRESSURE (mmHg)	OUTPUT VOLTAGE (V)
(ft)	(m)		
0	0	760	3.4 - 3.8
1 000	305	733	3.3 - 3.7
2 000	610	707	3.1 - 3.6
3 000	914	682	3.0 - 3.5
4 000	1 219	658	2.9 - 3.3
5 000	1 524	634	2.8 - 3.2
6 000	1 829	611	2.7 - 3.1
7 000	2 133	589	2.6 - 3.0
8 000	2 438	567	2.5 - 2.9
9 000	2 743	546	2.4 - 2.8
10 000	3 048	526	2.3 - 2.7

If check result is not satisfactory, replace pressure sensor.

5. Install pressure sensor and connect vacuum hose securely.
6. Connect pressure sensor coupler securely.

THROTTLE POSITION SENSOR (TPS)

Inspection

1. Disconnect negative cable at battery and TPS wires at the coupler.
2. Using ohmmeter, check the resistance between each two terminals.

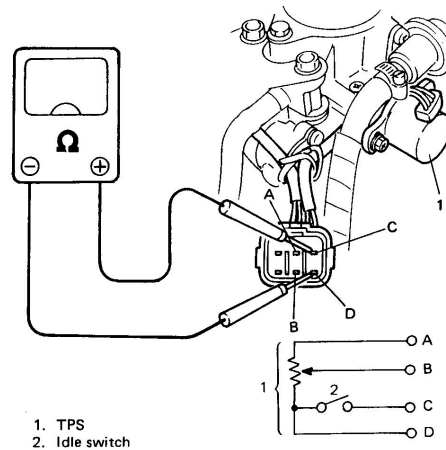

Fig. 4A-134 Checking TPS

Resistance between C and D terminals (Idle switch)	When throttle lever-to-stop screw clearance is 0.2 mm (0.008 in)	0 – 500 Ω
	When throttle lever-to-stop screw clearance is 0.4 mm (0.016 in)	∞ (Infinity)
Resistance between A and D terminals	—————	3.5 – 6.5 k Ω
Resistance between B and D terminals	When throttle valve is at idle position	0 – 2 k Ω
	When throttle valve is fully open	2 – 6.5 k Ω
NOTE: <ul style="list-style-type: none"> • When checking resistance at idle position, apply –50 cmHg vacuum to throttle opener to move throttle valve to idle position. • There should be more than 2 kΩ resistance difference between when throttle valve is at idle position and when it is fully open. 		

If idle switch check result is not satisfactory, adjust installation angle of TPS and then check again.

If found defective in above check, replace.

3. Connect TPS coupler securely and battery negative cable to battery.

Adjustment

1. Disconnect battery negative cable at battery and TPS coupler.
2. Disconnect throttle opener vacuum hose from VSV and connect vacuum pump gauge to hose disconnected.

Apply –50 cmHg vacuum to throttle opener to move throttle valve to idle position.

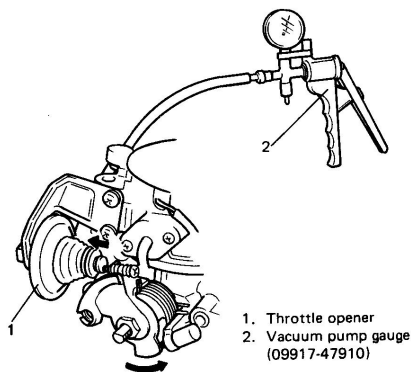

Fig. 4A-135 Applying Vacuum to Throttle Opener

3. Insert 0.3 mm (0.012 in.) thickness gauge between throttle valve lever and throttle stop screw.

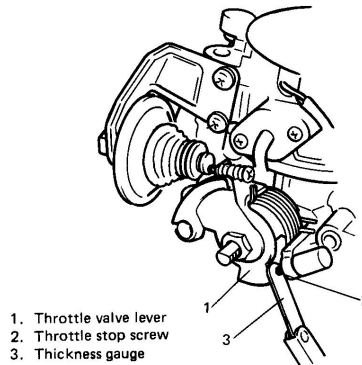

Fig. 4A-136 Inserting Thickness Gauge

4. Loosen TPS mounting bolts.
5. Connect ohmmeter between C and D terminals of TPS coupler.
6. First, turn TPS clockwise fully and then counterclockwise gradually to find position where ohmmeter reading changes from ∞ (infinity) to 0 (zero). Then fix TPS at that position by tightening bolts to specified torque.

Tightening torque of throttle position sensor bolt	N-m	kg-m	lb-ft
	3.5	0.35	2.5

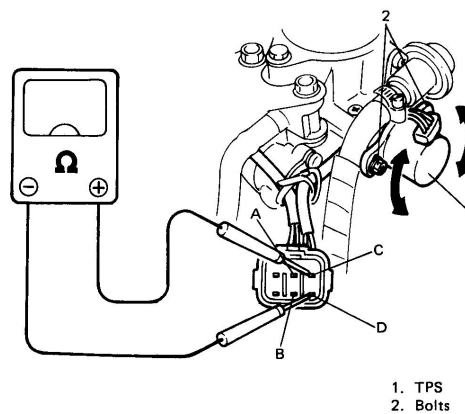

Fig. 4A-137 Adjusting Installation Angle of TPS

7. Check that there is no continuity between terminals C and D when 0.4 mm (0.016 in) thickness gauge is inserted.
8. Check that there is continuity between terminals C and D when 0.2 mm (0.008 in) thickness gauge is inserted.

If check result is unsatisfactory in steps 7 and 8, it means that installation angle of TPS is not adjusted properly. Therefore, start all over again from step 1.

CAUTION:
As throttle stop screw is factory adjusted precisely, don't remove or adjust it.

9. Connect coupler to TPS securely, connect throttle opener vacuum hose to VSV and connect battery negative cable.

Removal

1. Disconnect negative cable at battery.
2. Disconnect TPS coupler.
3. Pull out TPS wire harness terminals from coupler after unlocking terminal lock.

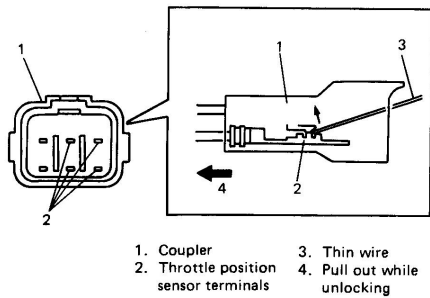

Fig. 4A-138 Removing Terminals

4. Remove TPS from throttle body.

Installation

1. Install TPS to throttle body.

Fit sensor to throttle body in such way that its adjusting holes are a little away from sensor mounting bolt holes as shown in Fig. 4A-139 and turn sensor clockwise so that those holes align. Then hand-tighten sensor mounting bolts in aligned holes.

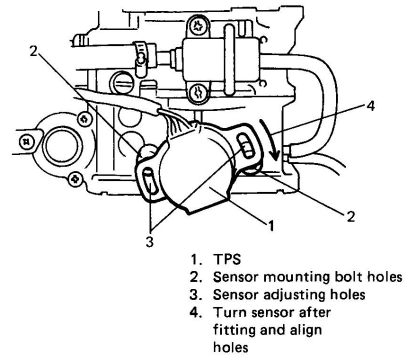

Fig. 4A-139 Installing TPS

2. Insert TPS terminals into coupler and check to make sure that they are locked.

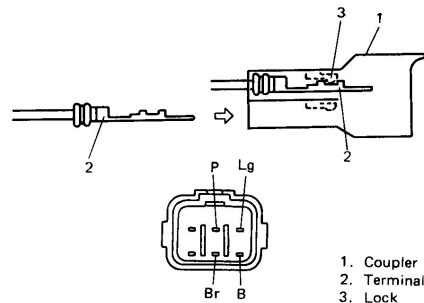

Fig. 4A-140 Inserting Terminals

3. Adjust installation angle of TPS according to procedure described in item "Adjustment".
4. Connect battery negative cable to battery.

AIR TEMPERATURE SENSOR (ATS)

Removal

1. Disconnect negative cable from battery.
2. Disconnect ATS coupler.
3. Remove ATS from intake manifold.

Inspection

Immerse temperature sensing part of ATS in water (or ice) and measure resistance between sensor terminals while heating water gradually. If measured resistance doesn't show such characteristic as shown in Fig. 4A-142, replace air temperature sensor.

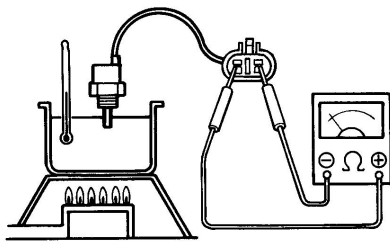

Fig. 4A-141 Checking ATS

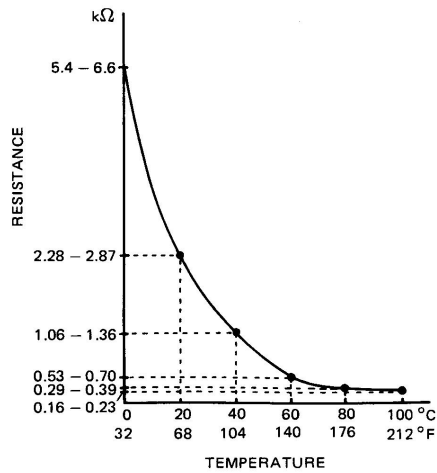

Fig. 4A-142 ATS Characteristic

4A-94

Installation

Reverse removal procedure noting the following.

- Clean mating surface of sensor and intake manifold.
- Use new gasket.
- Tighten ATS to specified torque.

Tightening torque for ATS	N-m	kg-m	lb-ft
	10 - 20	1.0 - 2.0	7.5 - 14.0

- Connect sensor coupler securely.

WATER TEMPERATURE SENSOR (WTS)

Removal

1. Disconnect battery negative cable from battery.
2. Drain cooling system.
3. Disconnect coupler from WTS.
4. Remove WTS from intake manifold.

Inspection

Immerse temperature sensing part of WTS in water and measure resistance between sensor terminals while heating water gradually. If measured resistance doesn't show such characteristic as shown below, replace WTS.

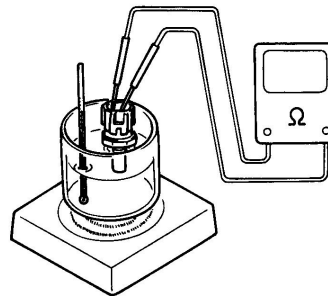

Fig. 4A-143 Checking WTS

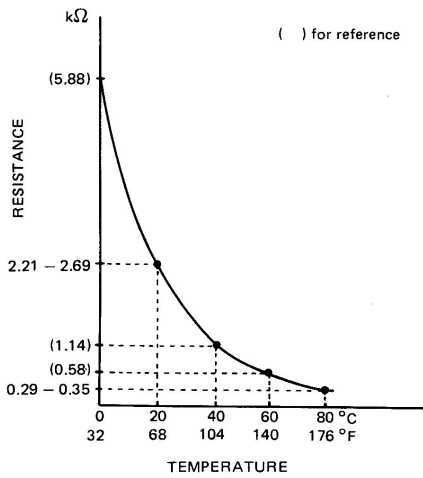

Fig. 4A-144 WTS Characteristic

Installation

Reverse removal procedure noting the following.

- Clean mating surfaces of sensor and intake manifold.
- Use new gasket.
- Tighten WTS to specified torque.

Tightening torque for water temperature sensor	N-m	kg-m	lb-ft
	12.5 - 17.5	1.25 - 1.75	9.5 - 12.5

- Connect coupler to sensor securely.
- Refill cooling system.

RECIRCULATED EXHAUST GAS TEMPERATURE SENSOR (REGTS) (California spec. model only)

Removal

1. Disconnect battery negative cable.
2. Disconnect REGTS coupler.
3. Remove REGTS.

Inspection

Immerse temperature sensing part of the sensor in water and measure resistance between sensor terminals while heating water gradually.

If measured resistance doesn't show such characteristic as shown in Fig. 4A-146, replace.

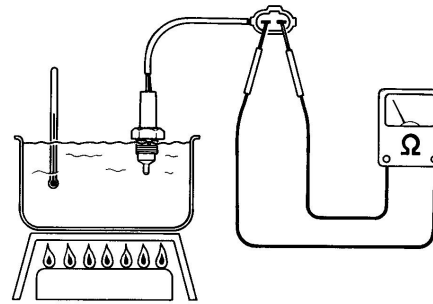

Fig. 4A-145 Checking REGTS

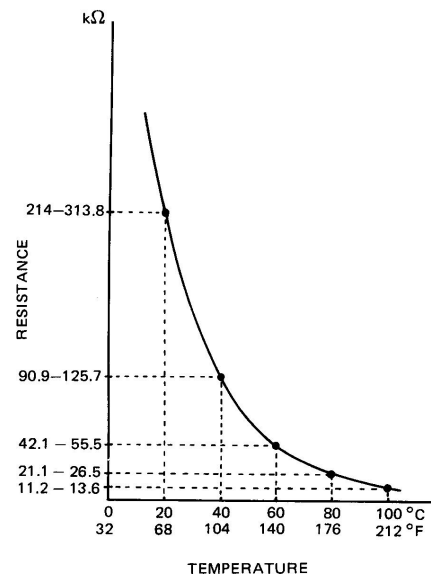

Fig. 4A-146 REGTS Characteristic

Installation

Reverse removal procedure noting the following.

- Tighten REGTS to specified torque.

Tightening torque for REGTS	N-m	kg-m	lb-ft
	10 - 20	1.0 - 2.0	7.5 - 14.0

- Connect sensor coupler securely.

OXYGEN SENSOR

Removal

WARNING:

To avoid danger of being burned, do not touch exhaust system when system is hot. Oxygen sensor removal should be performed when system is cool.

1. Disconnect negative cable from battery.
2. Disconnect coupler of oxygen sensor.
3. Remove oxygen sensor from exhaust manifold.

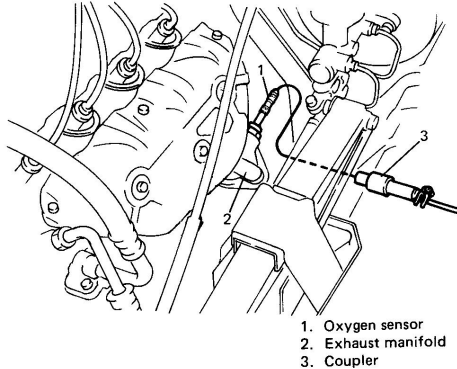

1. Oxygen sensor
2. Exhaust manifold
3. Coupler

Fig. 4A-147 Removing Oxygen Sensor

Installation

Reverse removal procedure noting the following.

- Tighten oxygen sensor to specified torque.

Tightening torque for oxygen sensor	N-m	kg-m	lb-ft
	45 - 55	4.5 - 5.5	33.0 - 39.5

- Connect coupler of oxygen sensor and clamp wire harness securely.
- After installing oxygen sensor, start engine and check that no exhaust gas leakage exists.

VEHICLE SPEED SENSOR (VSS)

Inspection

1. Disconnect negative cable at battery.
2. Remove combination meter from instrument panel.
3. Connect ohmmeter between "GND" screw and "RSW" screw of combination meter and turn cable joint of speedometer with a screwdriver. Ohmmeter indicator should move back

4A-96

and forth between 0 (zero) and ∞ (infinity) 4 times while cable joint is turned one full revolution.

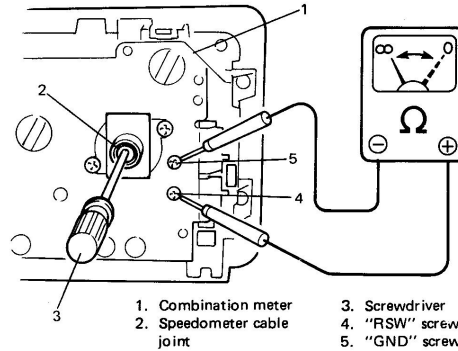

Fig. 4A-148 Checking Speed Sensor

Replace speedometer if check result is not satisfactory.

4. Install combination meter to instrument panel.
5. Connect negative cable to battery.

5TH SWITCH (Not for California Spec. Model)

Inspection

1. Disconnect negative cable from battery.
2. Disconnect 5th switch coupler.
The coupler is located beside igniter.

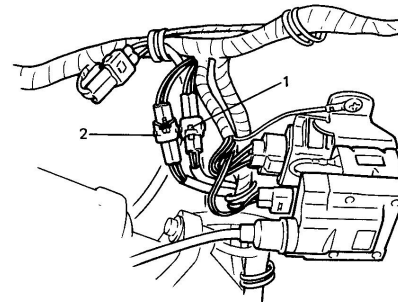

1. 5th switch coupler
2. Back-up light switch coupler

Fig. 4A-149 5th Switch Coupler Location

3. Connect ohmmeter to 5th switch terminals of disconnected coupler and check for continuity.

CONDITION	METER INDICATION
Shift lever in 5th gear position	Continuity
Shift lever in any other position than 5th gear position	∞ (Infinity)

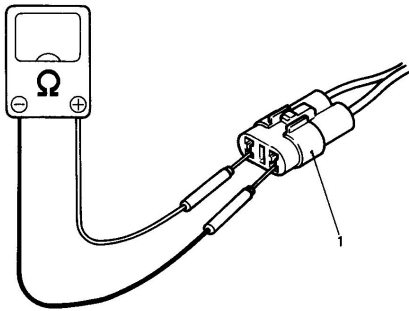

1. 5th switch coupler

Fig. 4A-150 Checking 5th Switch

- If check result is not satisfactory, replace 5th switch or repair wire harness.
4. Connect 5th switch coupler and battery negative cable.

CLUTCH SWITCH

Inspection

1. Disconnect clutch switch coupler.
2. Connect ohmmeter to clutch switch coupler terminals and check for continuity. Replace as necessary.

CONDITION	METER INDICATOR
Clutch released	∞ (Infinity)
Clutch depressed	Continuity

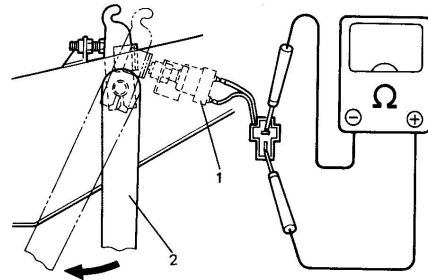

1. Clutch switch
2. Clutch pedal

Fig. 4A-151 Checking Clutch Switch

4. Connect coupler securely.

MAIN RELAY

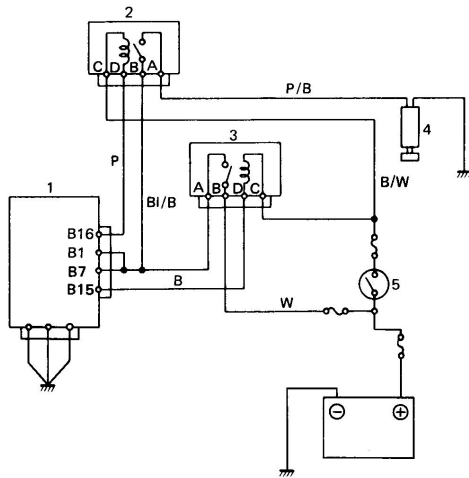

- 1. ECM
- 2. Fuel pump relay
- 3. Main relay
- 4. Fuel pump
- 5. Ignition switch

Fig. 4A-152 Main Relay and Fuel Pump Relay Circuits

NOTE:

Distinguish between main relay and fuel pump relay by wire colors.

Inspection

1. Disconnect negative cable at battery.
2. Remove main relay from ECM after disconnecting its coupler.

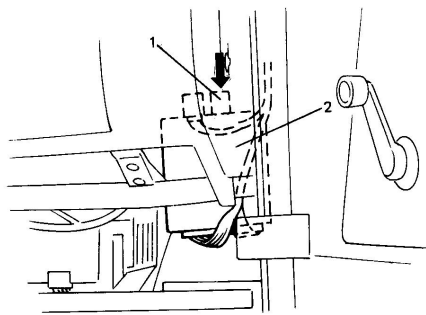

- 1. Main relay
- 2. ECM

Fig. 4A-153 Removing Main Relay

4A-98

3. Check resistance between each two terminals as in table below.

If check results are as specified, proceed to next operation check. If not, replace.

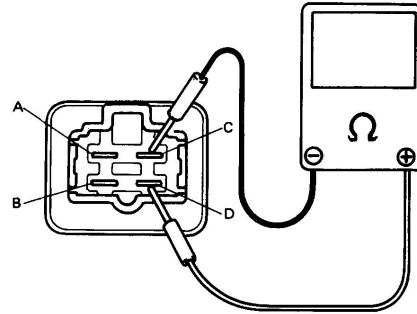

Fig. 4A-154 Checking Main Relay Resistance

TERMINALS	RESISTANCE
Between A and B	∞ (infinity)
Between C and D	56 – 84 Ω

4. Check that there is continuity between terminals "A" and "B" when battery is connected to terminals "C" and "D".

If found defective, replace.

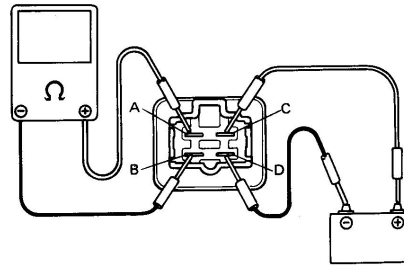

Fig. 4A-155 Checking Main Relay Operation

FUEL PUMP RELAY

Inspection

1. Remove fuel pump relay in the same way as main relay.
2. Structure of fuel pump relay is the same as that of main relay. Check its resistance and operation using the same procedure as that for main relay.
If found defective, replace.

FUEL CUT OPERATION

Inspection

NOTE:

Before inspection, check to make sure that gear shift lever is in neutral position, and that parking brake lever is pulled all the way up.

1. Warm up engine to normal operating temperature.
2. While listening to sound of injector by using sound scope or such, increase engine speed to higher than 3,000 r/min.
3. Check to make sure that sound to indicate operation of injector stops when throttle valve is closed instantly and it is heard again when engine speed is reduced to less than about 1,900 r/min.

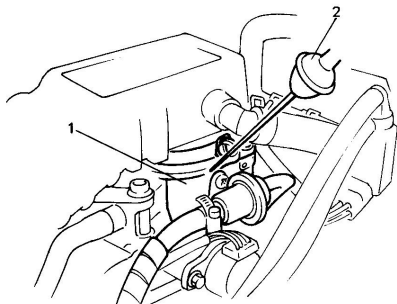

1. Throttle body
2. Sound scope

Fig. 4A-156 Checking Fuel Cut Operation

ISC SOLENOID VALVE

Inspection

1. With ignition switch "OFF", disconnect ISC solenoid valve coupler.
2. Check resistance between each two terminals of ISC solenoid valve.

Resistance of ISC solenoid valve	30 – 33 Ω
----------------------------------	------------------

If it is within specification, proceed to next operation check. If not, replace.

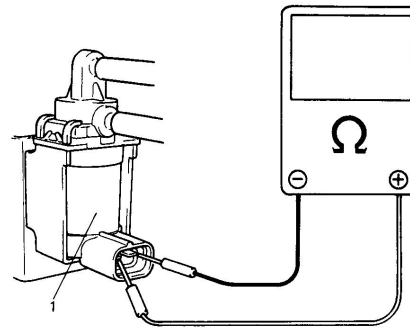

1. ISC solenoid valve

Fig. 4A-157 Checking Resistance

3. Warm up engine to normal operating temperature.
4. With engine running and ISC solenoid valve coupler disconnected, disconnect ISC solenoid valve hose from air cleaner case.
In this state, check that air is not drawn into the hose.

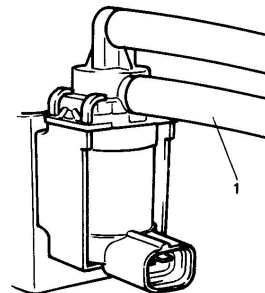

1. Hose from air cleaner case

Fig. 4A-158 Checking ISC Solenoid Valve (1)

- Under above condition, connect 12V-battery to ISC solenoid valve terminals and check that air is drawn into the hose.

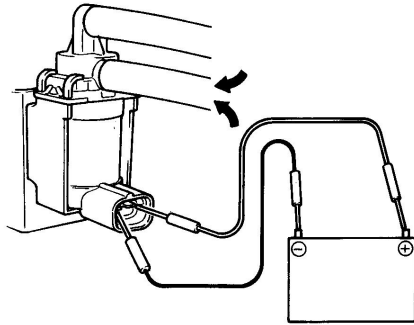

Fig. 4A-158-1 Checking ISC Solenoid Valve (2)

If check result is not satisfactory, replace ISC solenoid valve.

- Connect hose and coupler securely.

THROTTLE OPENER SYSTEM

System Inspection

- Warm up engine to normal operating temperature.
- Check that there is clearance between throttle stop screw and throttle lever at engine stop and cranking and that 0 – 1.0 second after engine start, throttle opener rod retracts and clearance disappears.

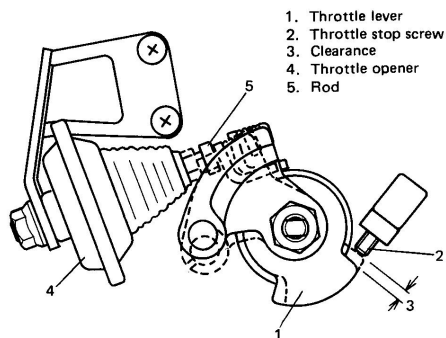

Fig. 4A-159 Checking Throttle Opener Operation
4A-100

If check result is not satisfactory, check vacuum hoses, throttle opener, VSV and system electric circuit.

Vacuum Hoses Inspection

Check hoses for connection, leakage, clog and deterioration. Replace as necessary.

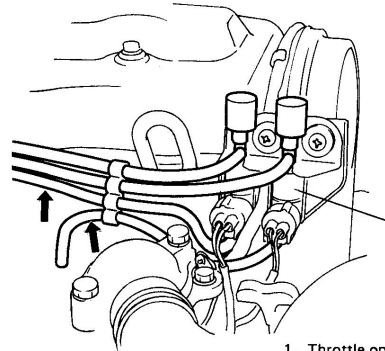

Fig. 4A-160 Checking Vacuum Hoses

Throttle Opener Inspection

- Disconnect vacuum hose from VSV.
- Connect vacuum pump gauge to hose disconnected in Step 1.
- Check that opener rod moves smoothly and that it is held at the same position when 50 cmHg vacuum is applied to opener.

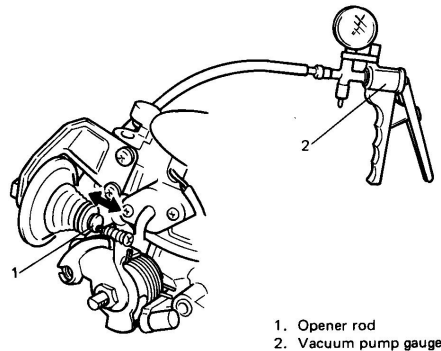

Fig. 4A-161 Checking Throttle Opener

If rod doesn't move smoothly, or it isn't held at the same position, replace.

VSV (Vacuum Switching Valve) Inspection

1. With ignition switch OFF, disconnect coupler from VSV.
2. Check resistance two terminals of VSV.

Resistance of throttle opener VSV	33 – 39 Ω
-----------------------------------	------------------

If resistance is as specified, proceed to next operation check. If not, replace.

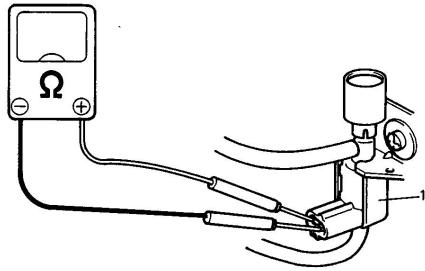

1. VSV (Brown)

Fig. 4A-162 Checking Resistance

3. Disconnect vacuum hoses from throttle opener and intake manifold.
4. Blow into hose "A". Air should come out of hose "B" and not out of filter.

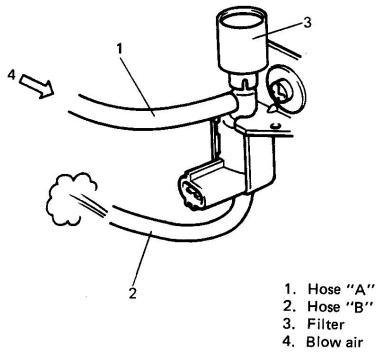

1. Hose "A"
2. Hose "B"
3. Filter
4. Blow air

Fig. 4A-163 Checking Opener VSV (1)

5. Connect 12V battery to VSV terminals. In this state, blow hose "A". Air should come out of filter and not out of hose "B".

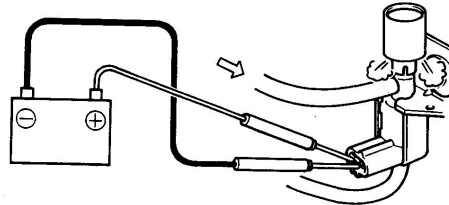

Fig. 4A-164 Checking Opener VSV (2)

If check result is not as described above, replace VSV.

6. Connect VSV coupler securely.
7. Connect vacuum hoses securely.

EGR SYSTEM

NOTE:

Before inspecting EGR system, be sure to confirm the following.

- Altitude is 3,870 ft, 1,180 m above sea level or lower and atmospheric pressure is 660 mmHg or higher.
- WTS, TPS and pressure sensor are in good condition.
- 5th switch signal is not fed into ECM (not for California spec. model).

If even one of the above conditions do not apply, EGR valve don't operate.

System Inspection

NOTE:

Before inspection, check to make sure that gear shift lever is in neutral position and that parking brake lever is pulled all the way up.

1. When engine is cool (cooling water temperature is below 53°C, 127°F), start engine and race it, and check that EGR valve diaphragm is not operating in this state, by touching diaphragm with finger.

CAUTION:

If EGR valve is hot, it may be necessary to wear gloves to avoid burning fingers.

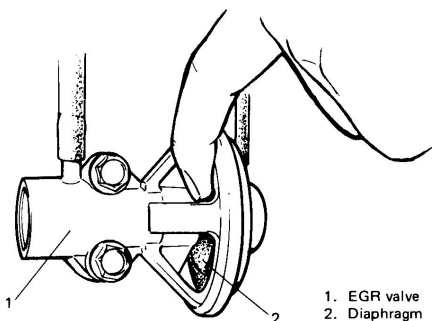

Fig. 4A-165 Checking EGR Valve Diaphragm

2. Warm up engine to normal operating temperature and race it after warming up. Then check to be sure that diaphragm moves toward 1 in Fig. 4A-166 during acceleration and toward 2 during deceleration.

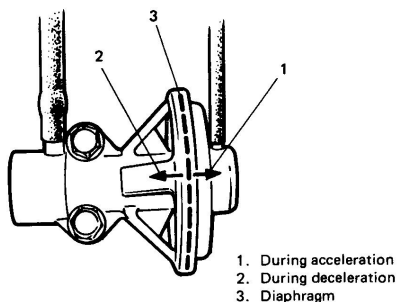

Fig. 4A-166 Movement of EGR Valve Diaphragm

4A-102

If EGR valve fails to operate properly, check vacuum hoses EGR valve, EGR modulator, VSV, wire harness and ECM.

3. Keep engine running at idle speed and open EGR valve by hand, and engine should either stop or reduce its speed. If neither occurs, EGR passage is clogged. Clean it.

Vacuum Hose Inspection

Check hoses for connection, leakage, clog and deterioration. Replace as necessary.

EGR Valve Inspection

1. Disconnect vacuum hose from EGR modulator.
2. Connect vacuum pump gauge to its hose.
3. Check that EGR valve diaphragm moves smoothly and that it is held at the same position when 20 cmHg vacuum is applied to EGR valve.
If diaphragm doesn't move smoothly, or it isn't held at the same position, replace EGR valve.

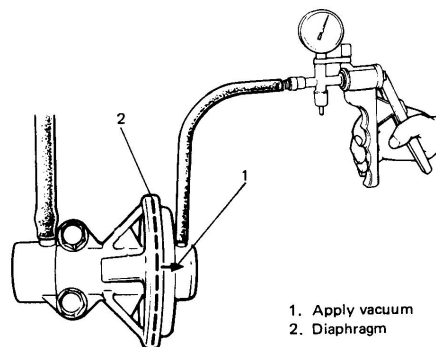

Fig. 4A-167 Checking EGR Valve

4. After checking, be sure to connect vacuum hose.

EGR Modulator Inspection

1. Check filter for contamination and damage.
Using compressed air, clean filter.

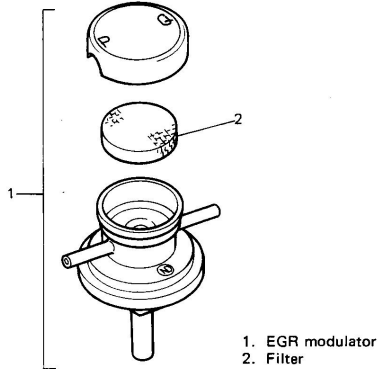

Fig. 4A-168 Filter of EGR Modulator

2. Remove EGR modulator and plug nozzle with finger. Blow air into another nozzle and check that air passes through to air filter side freely.

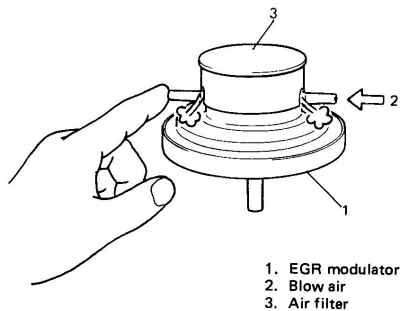

Fig. 4A-169 Checking EGR Modulator (1)

3. Connect vacuum pump gauge to nozzle "P" and plug nozzle "Q" with finger. While blowing air into nozzle "A", operate vacuum pump gauge and check that vacuum is applied to modulator. Then stop blowing nozzle "A" and check that vacuum pump gauge indicates "0" (zero). If check result is not satisfactory, replace EGR modulator.

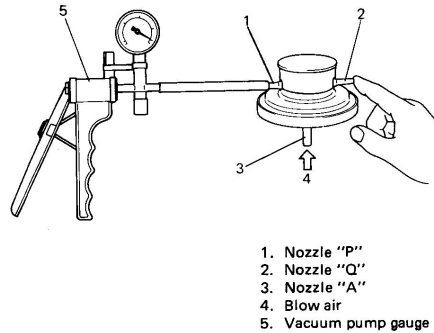

Fig. 4A-170 Checking EGR Modulator (2)

4. After checking, install modulator and connect hoses securely. Refer to emission control information label for connection.

VSV (Vacuum Switching Valve) Inspection

1. With ignition switch OFF, disconnect coupler from VSV.
2. Check resistance between two terminals of VSV.

Resistance of EGR VSV	33 – 39 Ω
-----------------------	-----------

If resistance is as specified, proceed to next operation check. If not, replace.

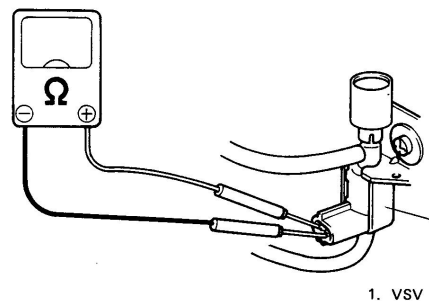

Fig. 4A-171 Checking Resistance

3. Disconnect vacuum hoses from EGR modulator and throttle body.
4. Blow into hose "A". Air should come out of hose "B" and not out of filter.

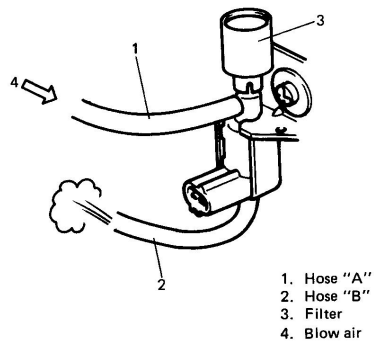

Fig. 4A-172 Checking Opener VSV (1)

5. Connect 12V-battery to VSV terminals. In this state, blow hose "A". Air should come out of filter and not out of hose "B".

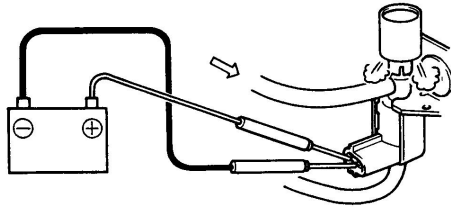

Fig. 4A-173 Checking Opener VSV (2)

If check result is not as described above, replace VSV.

6. Connect VSV coupler securely.
7. Connect vacuum hoses securely.

4A-104

SPECIAL TOOLS

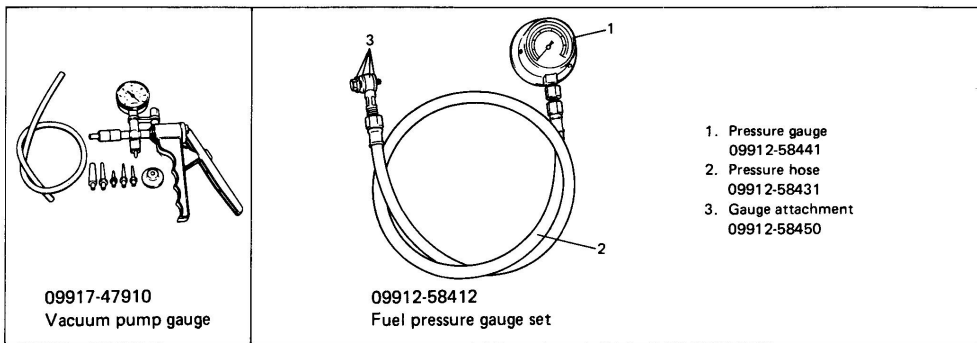

RECOMMENDED TORQUE SPECIFICATIONS

Fastening parts	Tightening torque		
	N·m	kg·m	lb·ft
Throttle body mounting bolt	18 – 28	1.8 – 2.8	13.5 – 20.0
Fuel inlet pipe bolt of throttle body	8 – 12	0.8 – 1.2	6.0 – 8.5
Throttle upper and lower body screw	3.5	0.35	2.5
Fuel pressure regulator screw	3.5	0.35	2.5
Injector cover screw	2.0	0.2	1.4
TPS bolt	3.5	0.35	2.5
ATS	10 – 20	1.0 – 2.0	7.5 – 14.0
WTS	12.5 – 17.5	1.25 – 1.75	9.5 – 12.5
REGTS	10 – 20	1.0 – 2.0	7.5 – 14.0
Oxygen sensor	45 – 55	4.5 – 5.5	33.0 – 39.5

SECTION 5

EMISSION CONTROL SYSTEM

CONTENTS

GENERAL DESCRIPTION	5-2
Vehicle Emission Control Information Label	5-2
Positive Crankcase Ventilation (PCV) System	5-2
Evaporative Emission Control System	5-3
Three-Way Catalyst	5-4
Exhaust Gas Recirculation (EGR) System]	Refer to SECTION 4A of GROUP 1.
Fuel Feed Back System (Compensation)]	
DIAGNOSIS	Refer to SECTION 2 and SECTION 4A of GROUP 1.
ON VEHICLE SERVICE	5-4
General	5-4
PCV System	5-4
Evaporative Emission Control System	5-5
EGR System]	Refer to SECTION 4A of GROUP 1.
Fuel Feed Back System (Oxygen sensor)]	

GENERAL DESCRIPTION

VEHICLE EMISSION CONTROL INFORMATION LABEL

The Vehicle Emission Control Information Label is located under hood. The label contains important emission specifications and setting procedures, as well as a vacuum hose schematic with emission components identified.

When servicing the engine or emission systems, the Vehicle Emission Control Information Label should be checked for up-to-date information.

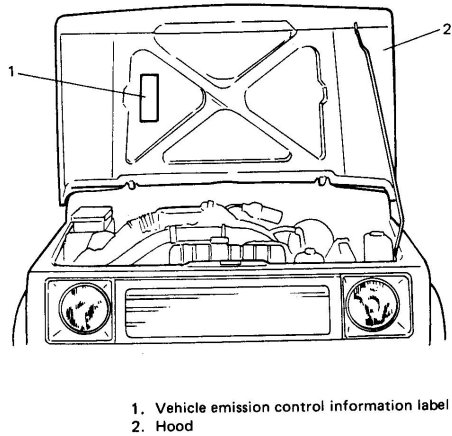

Fig. 5-1 Vehicle Emission Control Information Label

POSITIVE CRANKCASE VENTILATION (PCV) SYSTEM

The term "blow-by gas" stands for the compressed gas and exploded gas which blow through cylinder-to-piston clearance, which contain a large amount of unburned gases such as CO and HC. The PCV (Positive Crankcase Ventilation) system is provided to prevent the blow-by gas from being emitted into atmosphere and it operates as follows.

When the vacuum in the intake manifold is low (throttle valve open), the PCV valve is wide open due to its spring force. Thus a large amount of the blow-by gas is drawn into the intake manifold.

On the other hand, when the vacuum in the manifold is high, the PCV valve opening is limited due to the high vacuum. Thus the amount of the blow-by gas drawn into the intake manifold is small.

For '91, '92, '93 model

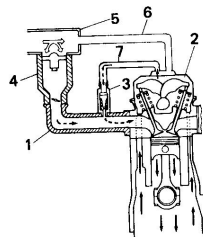

For '90 model

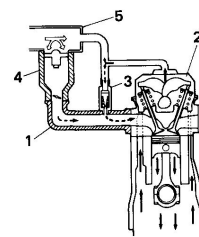

- | | |
|------------------------|---------------------------------------|
| 1. Intake manifold | 7. PCV hose |
| 2. Cylinder head cover | 8. Blow-by gas |
| 3. PCV valve | 9. Fresh air |
| 4. Throttle body | 10. Blow-by gas and fresh air mixture |
| 5. Air intake case | |
| 6. Breather hose | |

Fig. 5-2 PCV System Operation

EVAPORATIVE EMISSION CONTROL SYSTEM

An evaporative emission control system is used to prevent emission of fuel vapor.

The vapor generated in the fuel tank while driving or the engine at a stop enters the charcoal canister where the charcoal absorbs and stores the fuel vapor.

Only when the following conditions are all satisfied, fuel vapor in the canister is sucked into throttle body together with fresh air.

- Engine is running
- Engine cooling water temp. is high (Normal operating temperature)
- Throttle valve opens larger than idle position.

In this state, the canister is purged or cleaned by air drawn through the filter at the bottom of the canister.

When engine cooling water temp. is low, purge passage is closed by BVSV.

In this state, the canister is not purged.

The check valves ("A" and "B") are provided to keep the pressure in the fuel tank constant. When the pressure in the fuel tank becomes positive and reaches its specified value, it opens the valve "A" to let the vapor flow into the charcoal canister. On the other hand, when the pressure in the fuel tank becomes negative and reaches its specified value, it opens the valve "B" to let the air flow into the fuel tank.

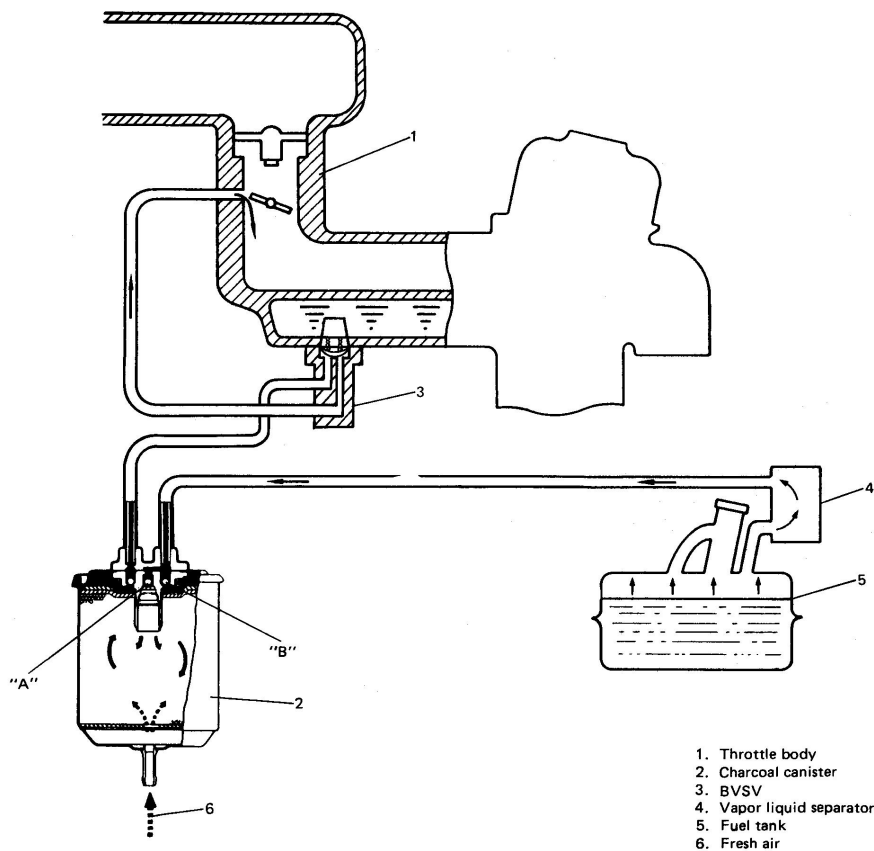

Fig. 5-3 Evaporative Emission Control System

THREE-WAY CATALYST

The three-way catalyst is provided in the exhaust system (exhaust center pipe). The function of the catalyst is to reduce the emission of CO, HC and NOx in the exhaust gas by oxidizing or converting them into CO₂, H₂O and N₂ respectively.

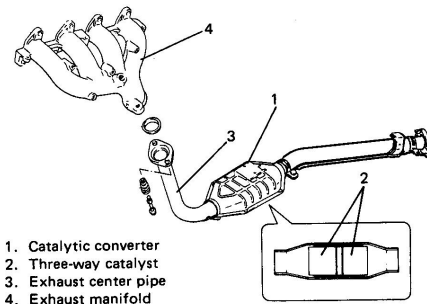

Fig. 5-4 Catalytic Converter

ON VEHICLE SERVICE

GENERAL

When the emission control hoses are disconnected and the system's component is removed for service, reinstall the component properly, and route and connect hoses correctly after service. Refer to Fig. 4A-101, and Vehicle Emission Control Information Label for proper routing of hoses.

PCV SYSTEM

NOTE:

Be sure to check that there is no obstruction in PCV valve or its hoses before adjusting engine idle speed, for obstructed PCV valve or hose hampers its accurate adjustment.

PCV HOSE

Check hoses for connection, leakage, clog, and deterioration. Replace as necessary.

PCV VALVE

1. Disconnect PCV hose from PCV valve.
2. Run engine at idle.
3. Place your finger over end of PCV valve to check for vacuum. If there is no vacuum, check for clogged valve. Replace as necessary.

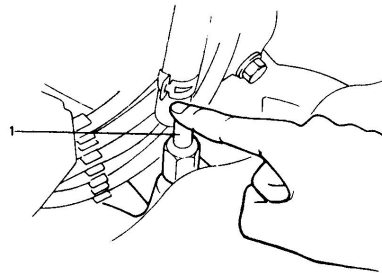

1. PCV valve

Fig. 5-5 Checking Vacuum

4. After checking vacuum, stop engine and check PCV valve for sticking.

With engine stopped, connect a new hose to PCV valve.

Blow air into new hose and check that air flows with difficulty from cylinder head side to intake manifold side. If air flows without difficulty, valve is stuck in "Open" position. Replace PCV valve.

WARNING:
Do not suck air through PCV valve. Petroleum substances inside the valve and fuel vapor inside the intake manifold are harmful.

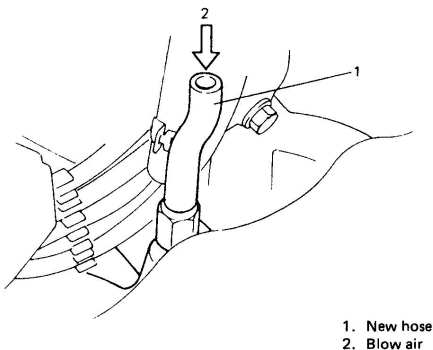

Fig. 5-6 Checking PCV Valve for Sticking

5. Connect PCV hose and clamp securely.

EVAPORATIVE EMISSION CONTROL SYSTEM

VACUUM HOSES

Check hoses for connection, leakage, clog and deterioration. Replace as necessary.

CHARCOAL CANISTER

WARNING:
DO NOT SUCK nozzles on canister. Fuel vapor inside canister is harmful.

1. Disconnect hoses from canister.

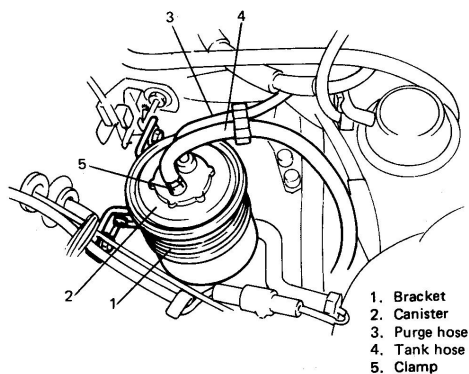

Fig. 5-7 Canister Hoses

2. Remove canister.
3. With pipe "C" plugged with finger blow air into pipe "A" strongly, and air should come out from pipe "B".
4. When air is blown into pipe "B", air should not pass through pipe "A" and "C".
5. When air is blown into pipe "C", air should come out from pipes "A" and "B".

If operation differs from above description, canister must be replaced.

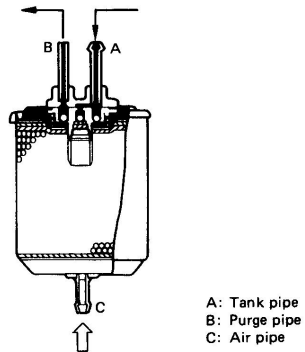

Fig. 5-8 Checking Canister

6. Install canister and connect hoses.

BVSV (Bi-metal Vacuum Switching Valve)

NOTE:

For rough operation check, BVSV needs not be removed from intake manifold. It can be checked by cooling and warming up engine to obtain test conditions as in Steps 3 and 4 below. (For such check, other steps are not applicable.)

1. Drain cooling system when engine is cold.
2. Disconnect vacuum hoses and remove BVSV from intake manifold.
3. While keeping BVSV cool (below 55°C 131°F), blow nozzle "3". Air should not come out of nozzle "4".

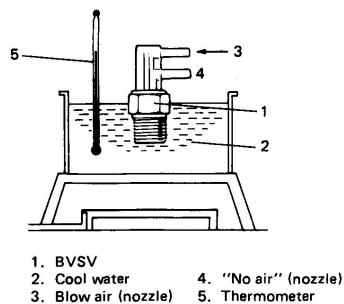

Fig. 5-9 Checking BVSV (1)

4. While keeping BVSV warm (above 65°C 149°F) in hot water, blow nozzle "3". Air should come out of nozzle "4".

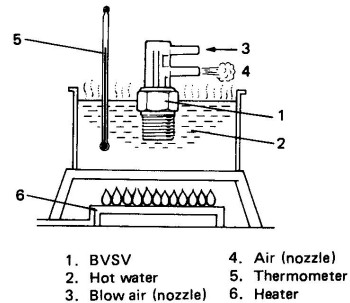

Fig. 5-10 Checking BVSV (2)

5. Reinstall BVSV to intake manifold. Before installing, wind sealing tape on its thread.
6. Connect vacuum hoses. Refer to Fig. 4A-101 for connection.

SECTION 8

IGNITION SYSTEM

CONTENTS

GENERAL DESCRIPTION	8-2
DIAGNOSIS	8-3
ON-CAR SERVICE	8-4
Ignition Spark Test	8-4
High Tension Cords	8-4
Spark Plugs	8-5
Noise Suppressor	8-5
Ignition Coil	8-5
Distributor	8-6
Ignition Timing	8-6
DISTRIBUTOR UNIT	8-8
Important Reminders for Reassembly	8-8
Removal	8-9
Installation	8-9

GENERAL DESCRIPTION

The ignition system used for this vehicle has an ESA (Electronic Spark Advance) system and consists of the following parts.

- ECM

It detects the engine condition through the signals from the sensors, determines the most suitable ignition timing and time for electricity to flow to the primary coil and sends a signal to the power unit.
- Igniter (Power unit)

It turns ON and OFF the primary current of the ignition coil according to the signal from ECM. At the same time, it send ignition signal (fail safe signal) to ECM. If no fail safe signal is transmitted to the ECM while engine is running, fuel cut operation is executed.
- Ignition coil

When the ignition coil primary current is turned OFF, a high voltage is induced in the secondary winding.
- Distributor

It distributes a high voltage current to each plug.

- High-tension cords and spark plugs
- CAS (Crank Angle Sensor)

Located in the distributor, it converts the crank angle into voltage variation and sends it to ECM. For its details, refer to Section 4A.
- Pressure sensor, TPS WTS and test switch terminal

For their details, refer to Section 4A.

In ESA system, the ECM is programmed for the best ignition timing under every engine condition. Receiving signals which indicate the engine condition from the sensors, e.g., engine revolution, intake air volume, coolant temperature, etc., it selects the most suitable ignition timing from its memory and operates the igniter. Thus ignition timing is controlled to yield the best engine performance. For more information, refer to Section 4A.

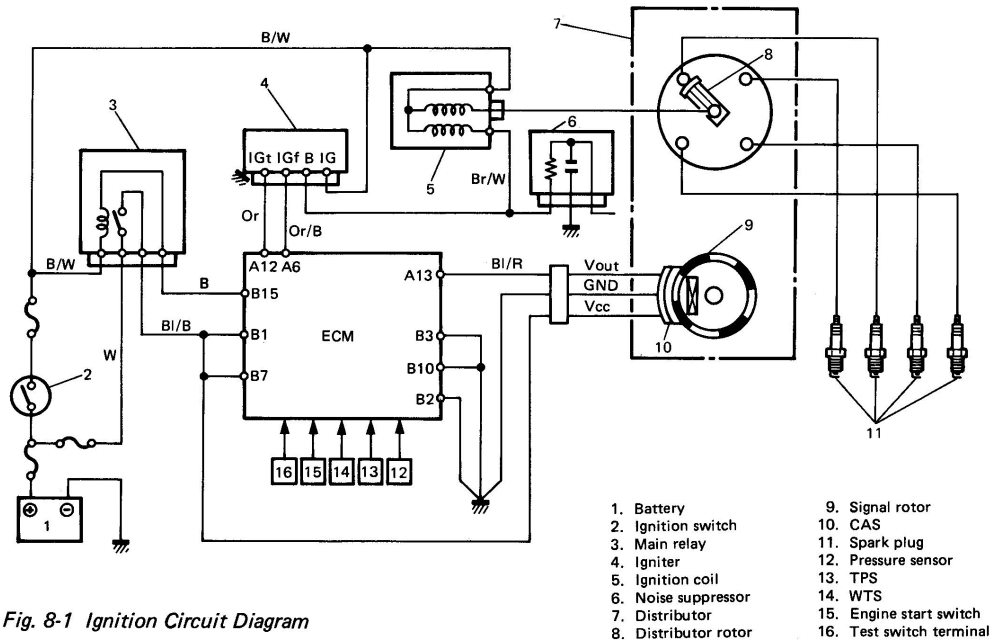

Fig. 8-1 Ignition Circuit Diagram

DIAGNOSIS

Condition	Possible cause	Correction
Engine cranks, but will not start or hard to start	No spark <ul style="list-style-type: none"> ● Faulty spark plug(s) ● Blown fuse for ignition coil ● Loose connection or disconnection of lead wires or high-tension cord(s) ● Faulty high-tension cord(s) ● Cracked rotor or cap ● Faulty ignition coil ● Faulty noise suppressor ● Faulty CAS ● Faulty igniter ● Faulty ECM Maladjusted ignition timing	Adjust, clean or replace Replace Connect securely Replace Replace Replace Replace Replace Replace Adjust
Poor fuel economy or engine performance	<ul style="list-style-type: none"> ● Incorrect ignition timing ● Faulty spark plug(s) or high tension cord(s) ● Faulty ECM 	Adjust Adjust, clean or replace Replace

SELF-DIAGNOSIS

1. To insure correct diagnosis, check to confirm that battery voltage is within standard value when engine is standstill.
2. Turn on ignition switch and make sure that "CHECK ENGINE" light lights.
3. If engine will not start but cranking is possible, crank it for more than 3 seconds.
4. While ignition switch is ON, insert a spare fuse to DIAG SW in fuse box and then read diagnostic code (observe "CHECK ENGINE" light).

DIAGNOSTIC CODE NO. 42



ECM indicates that no CAS signal is inputted for more than 3 seconds while engine is being cranked.

Diagnose trouble according to "Diagnostic Flow Chart for Code No. 42" in Section 4A.

DIAGNOSTIC CODE NO. 41



ECM indicates that no ignition signal is inputted while engine is running or being cranked.

Diagnose trouble according to "Diagnostic Flow Chart for Code No. 41" in Section 4A.

ON-CAR SERVICE

IGNITION SPARK TEST

1. Disconnect injector coupler.

WARNING:

Without disconnection of injector coupler, combustible gas may come out from spark plug holes during this test and may get ignited in engine room.

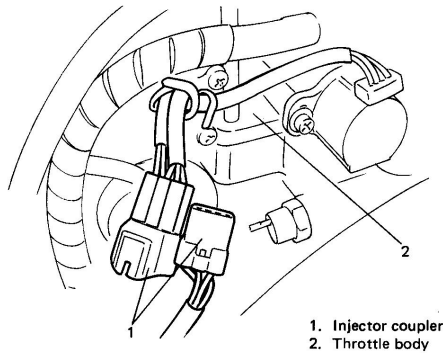

1. Injector coupler
2. Throttle body

Fig. 8-2 Disconnecting Injector Coupler

2. Remove spark plugs and connect them to high tension cords, and then ground spark plugs.
3. Crank engine and check if each spark plug sparks.
4. If no spark is emitted, inspect high tension cords, spark plugs, ignition coil, distributor, etc.

HIGH TENSION CORDS

1. Remove high tension cord at ignition coil while gripping its cap.
2. Remove distributor cap installed with high tension cords.
3. Pull out high tension cords from spark plugs while gripping each cap.
4. Remove high tension cord clamp from cylinder head cover.

CAUTION:

- Removal of high tension cords together with clamps will be recommended so as not to damage their inside wire (resistive conductor).
- For the same reason, pull out each connection by gripping cap portion.

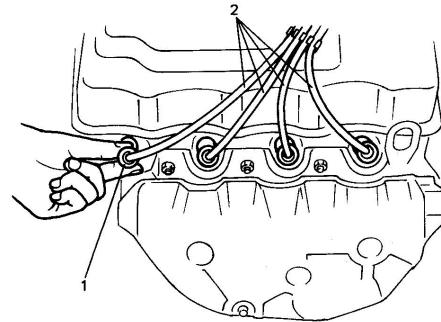

1. Cap
2. High tension cord

Fig. 8-3 Removing High Tension Cord

5. Measure resistance of high tension cord by using ohmmeter.

High tension cord resistance	10 – 22 kΩ/m 3.0 – 6.7 kΩ/ft
------------------------------	---------------------------------

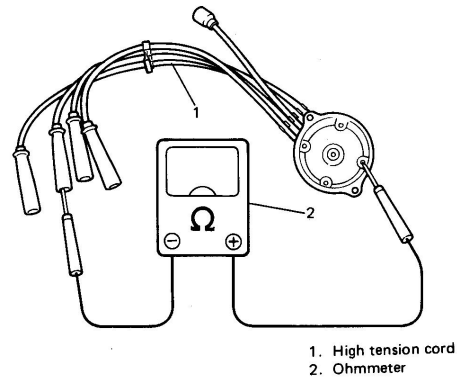

1. High tension cord
2. Ohmmeter

Fig. 8-4 Measuring High Tension Cord Resistance

- If resistance exceeds specification, inspect distributor terminal and replace high tension cord(s) and/or distributor cap as required.

CAUTION:

- Never attempt to use metal conductor high tension cords as replacing parts.
- Insert each cap portion fully when installing high tension cords.

SPARK PLUGS

- Pull out high tension cords by gripping their caps and then remove spark plugs.
- Inspect them for:
 - Electrode wear
 - Carbon deposits
 - Insulator damage
- If any abnormality is found, adjust air gap, clean with spark plug cleaner or replace them with specified new plugs.

Spark plug type	NGK	BPR5ES
	NIPPON DENSO	W20EPR-U
Air gap A	0.7 – 0.8 mm 0.027 – 0.031 in	

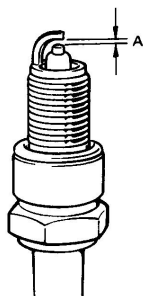

A: Spark plug gap

Fig. 8-5 Checking Spark Plug Gap

- Install spark plugs and torque them to specification.

Spark plug tightening torque	N·m	kg·m	lb·ft
	25 – 30	2.5 – 3.0	18.0 – 21.5

- Install high tension cords securely by gripping their caps.

NOISE SUPPRESSOR

- Disconnect coupler of noise suppressor.
- Using ohmmeter, check to be sure that condenser is not conductive and resistor has resistance of about 2.2 kΩ.
- If check result is not satisfactory, replace noise suppressor.

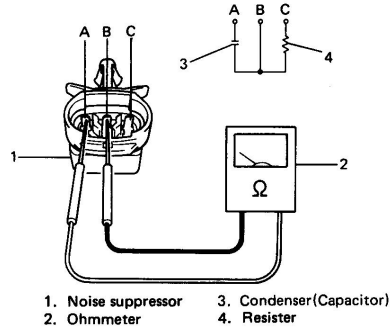

Fig. 8-6 Checking Noise Suppressor

IGNITION COIL

- Pull out high tension cord by gripping its cap.
- Disconnect ignition coil coupler.
- Measure primary and secondary coil resistances.

Ignition coil resistance (at 20°C, 68°F)	Primary	0.9 – 1.1 Ω
	Secondary	10.2 – 13.8 kΩ

PRIMARY

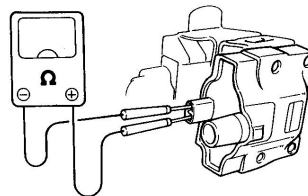

SECONDARY

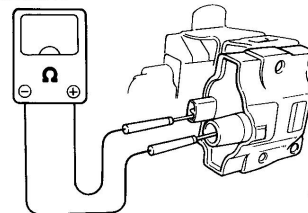

1. Ohmmeter

Fig. 8-7 Measuring Ignition Coil Resistance

- If resistance is out of specification, replace coil with new one.

DISTRIBUTOR

Distributor Cap and Rotor

Check cap and rotor for crack and their terminals for corrosion and wear. Replace as necessary.

CAS

- With ignition switch OFF, disconnect ECM coupler (Yellow).
- Connect voltmeter between "B1" terminal of green coupler (connected) and "A13" terminal of yellow coupler (disconnected).

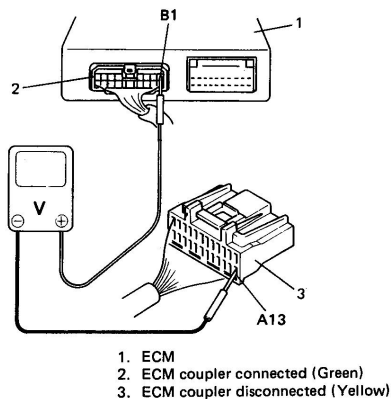

Fig. 8-8 Connecting Voltmeter

- Remove distributor cap, rotor and shield cover.

NOTE:

Check to make sure that magnet is free from any metal particles.

- Check voltage with signal rotor inserted between hall element and magnet ("A") and without it ("B") respectively.

"A"	Battery voltage
"B"	0 V

"A" : Magnetic flux cut off

"B" : Magnetic flux applied

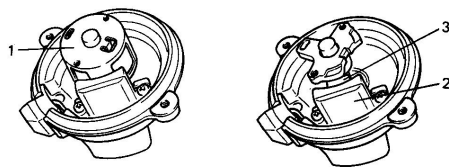

- Signal rotor
- Hall element
- Magnet

Fig. 8-9 Magnetic Flux Conditions for Voltage Check

If check result is not satisfactory, repair wire harness or replace CAS.

- After checking, connect ECM coupler securely and install distributor cap.

IGNITION TIMING

INSPECTION AND ADJUSTMENT

- Start engine and warm it up to normal operating temperature.
- Stop engine once, keep ignition switch ON for 5 seconds and then start engine again.
- Run engine at 2,000 r/min. for 5 minutes so that it is fully warmed and then keep it running at idle speed.
- Make sure that all of electrical loads except ignition are switched off.
- Check to be sure that idle speed is within specification.
- Set timing light to No. 1 high tension cord.
- Remove cap from monitor coupler beside battery. Connect "C" and "D" terminals of monitor coupler by using service wire so that ignition timing is fixed.

NOTE:

- "CHECK ENGINE" light lights at this time. This does not mean anything faulty but that "D" terminal (test switch terminal) is grounded.
- Using timing light, check to make sure that ignition timing doesn't change even when engine speed is increased. If it does, that indicates ungrounded "D" terminal which prevents accurate inspection and adjustment. Therefore, be sure to ground it securely.

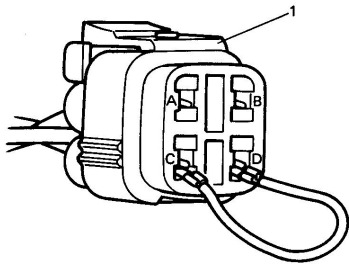

1. Monitor coupler
A: Duty check terminal
B: Diagnosis switch terminal
C: Ground
D: Test switch terminal

Fig. 8-10 Fixing Ignition Timing

8. Using timing light, check that timing is within specification.

Initial ignition timing (Test switch terminal grounded)	$8 \pm 1^\circ$ BTDC at 800 r/min.
---	------------------------------------

Ignition order	1 - 3 - 4 - 2
----------------	---------------

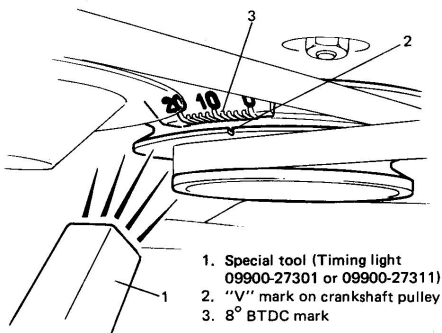
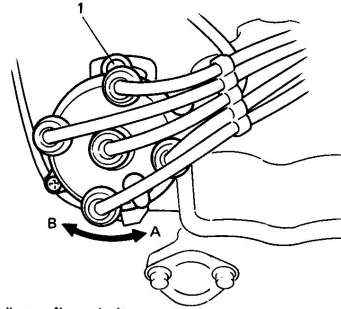

Fig. 8-11 Checking Ignition Timing

9. If ignition timing is out of specification, loosen flange bolts, adjust timing by turning distributor assembly while engine is running, and then tighten bolts.
10. After tightening distributor flange bolts, recheck that ignition timing is within specification.



1. Distributor flange bolt
A: To be advanced
B: To be retarded

Fig. 8-12 Adjusting Ignition Timing

11. After checking and/or adjusting, disconnect service wire from monitor coupler.

CAUTION:

Driving with test switch terminal grounded will cause damage to catalyst. Be sure to disconnect service wire after adjustment.

NOTE:

In this state, ignition timing may vary more or less of 8° BTDC but it is nothing abnormal.

12. Check that increasing engine speed advances ignition timing. If not, check TPS (idle switch), test switch terminal circuit, engine start signal circuit and ECM.

DISTRIBUTOR UNIT

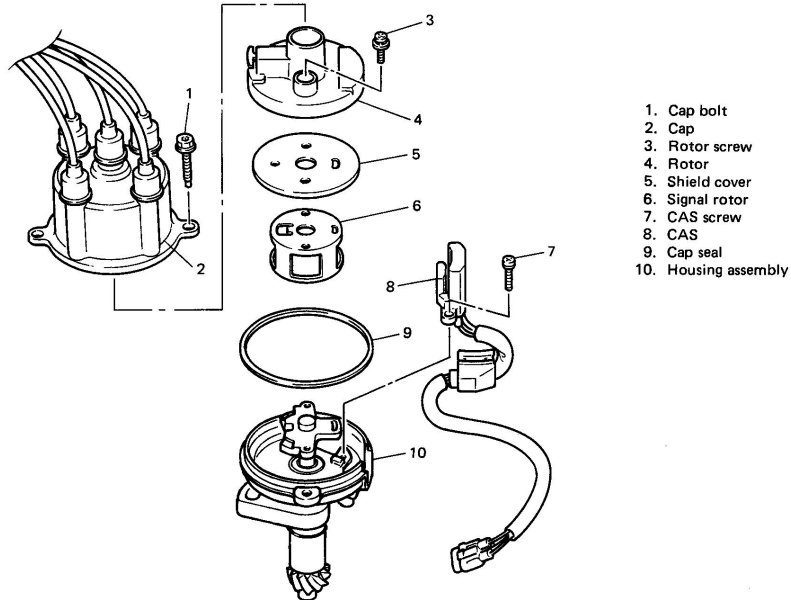

Fig. 8-13 Distributor Components

IMPORTANT REMINDERS FOR RE-ASSEMBLY

- Check to make sure that CAS magnet is free from any metal particles after installing CAS.
- When installing signal rotor, shield cover and rotor to shaft, be sure to fit lug "A" on rotor in oblong holes "B" in cover, signal rotor and shaft.

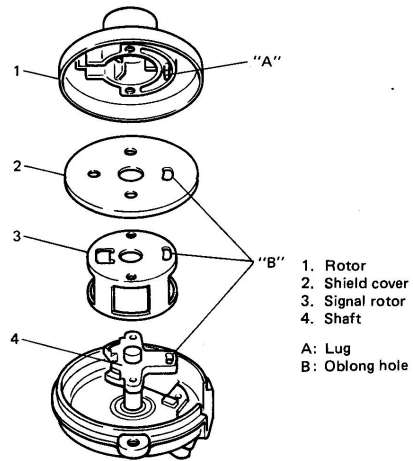

Fig. 8-14 Installing Signal Rotor

REMOVAL

1. Disconnect negative cable at battery.
2. Disconnect distributor (CAS) coupler.
3. Remove distributor cap.
4. Remove distributor flange bolt.
5. Pull out distributor housing assembly.

INSTALLATION

NOTE:

- Before installing distributor, check to make sure that its O ring is in good condition.
- If new O ring is installed, apply oil.

1. Turn over crankshaft in normal direction (clockwise as viewed from crankshaft pulley side) until "V" mark on pulley aligns with timing mark "0" (zero) on timing tab.

CAUTION:

After aligning two marks, remove cylinder head cover to visually confirm that the rocker arms are not riding on the camshaft comes at No. 1 cylinder. If the arms are found to be riding on the cams, turn over crankshaft 360° to align the two marks anew.

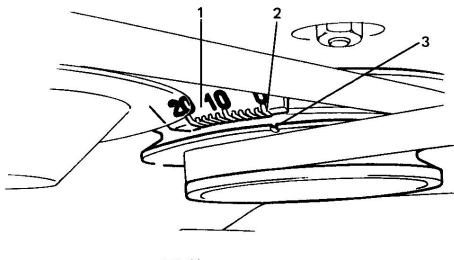

1. Timing tab
2. "0" mark
3. "V" mark (Timing notch) on crankshaft pulley

Fig. 8-15 Crankshaft Position

2. Turn rotor to make the center of rotor align with the cap bolt hole center on distributor housing as shown in Fig. 8-16.

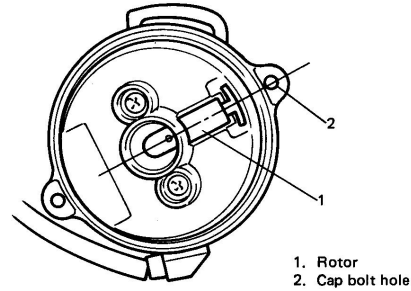

Fig. 8-16 Distributor Rotor Position

3. Insert the distributor into the gear case in such a way that the center of distributor flange will coincide with the distributor mounting screw hole provided in the distributor gear case. When inserting the distributor completely, position of distributor rotor becomes as shown in Fig. 8-17. Secure the distributor in place tentatively by making the mounting screw finger-tight.

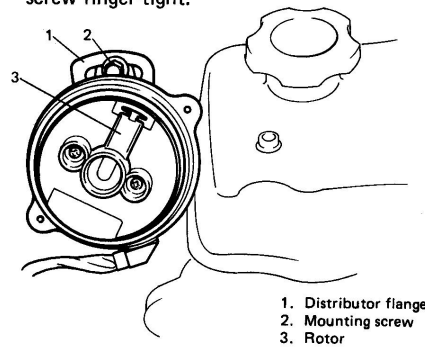

Fig. 8-17 Inserting Distributor

4. Check to make sure that rotor is in good condition.
5. Inspect distributor cap and clean or replace as required.
6. Make sure that distributor cap seal is placed properly and install cap, and then fasten it with screws.
7. Connect distributor coupler.
8. Connect negative cable at battery.
9. Check and adjust ignition timing as previously outlined.

SECTION 10

CHARGING SYSTEM

NOTE:

For the items not found in this section, refer to the same section of '88 MODEL SERVICE MANUAL.

CONTENTS

10-1. ALTERNATOR	10-1
GENERAL DESCRIPTION	10-1
DATA AND SPECIFICATION	10-2

10

10-1. ALTERNATOR

GENERAL DESCRIPTION

The maximum output of this alternator is 50A. Its structure and operation are the same as the one used for the '88 model vehicle. The component parts also remain the same except the rotor.

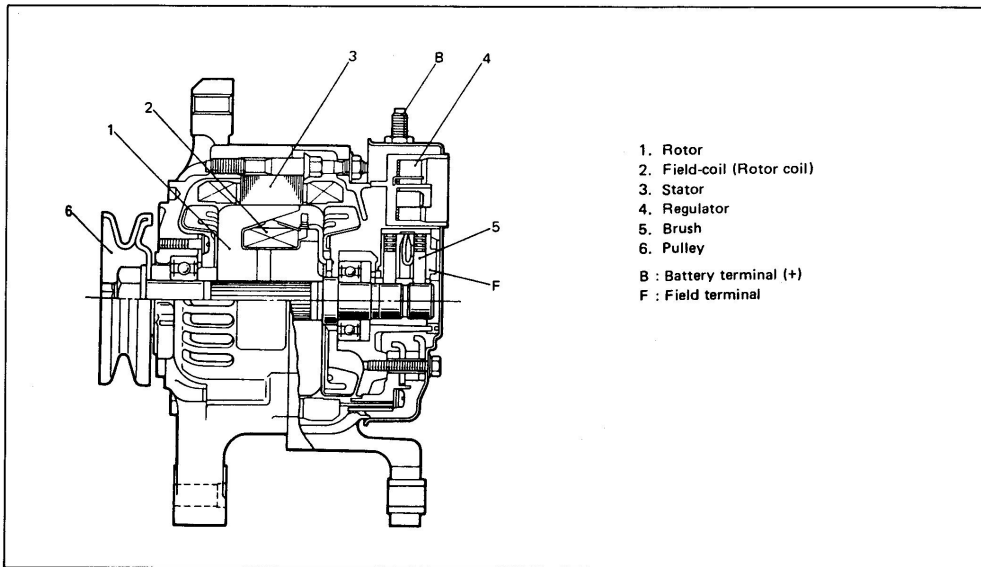

Fig. 10-1

10-1

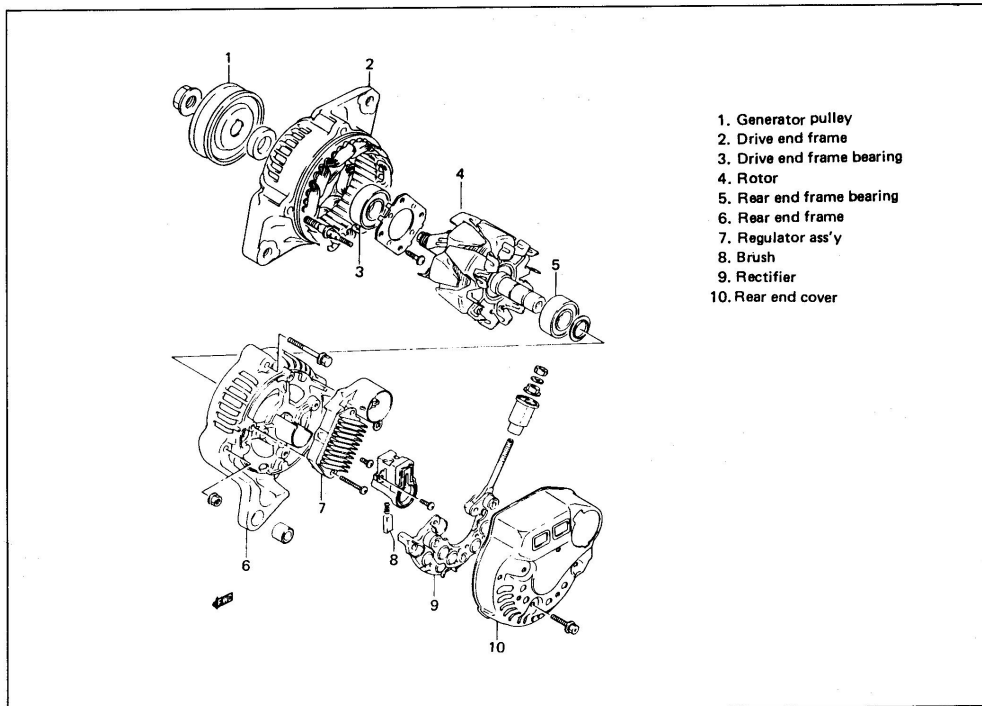

Fig. 10-2

DATA AND SPECIFICATION

Nominal operating voltage	12 volts
Max. alternator output	50A
Polarity	Negative ground
No-load alternator speed	1,110 rpm (r/min)
Regulated voltage	14.5 ± 0.3V
Direction of rotation	Clockwise as viewed from pulley side
Maximum permissible alternator speed	15,000 rpm (r/min)
Working temperature range	-30 ~ 90°C (-22 ~ 194°F)
Rectification	Full wave rectification

The graph given below shows the alternator frame temperature to output voltage relationship. Use it as reference when checking output of the alternator.

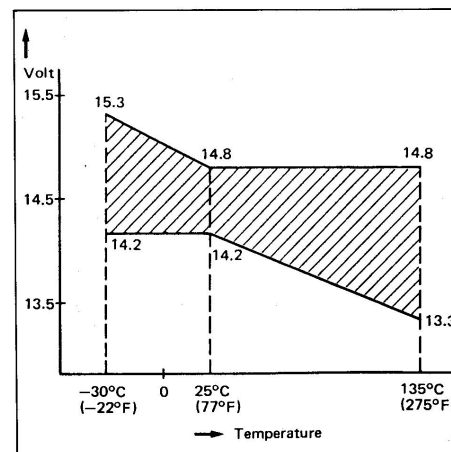

Fig. 10-3

SECTION 11

CLUTCH

NOTE:

For the items not found in this section, refer to the same section of '88 MODEL SERVICE MANUAL.

CONTENTS

11-5. MAINTENANCE SERVICES 11-1

11-5. MAINTENANCE SERVICES

NOTE:

For the maintenance service procedure not found in this section, refer to the same section of '88 MODEL SERVICE MANUAL.

Clutch Pedal Height

Check to make sure that clutch pedal height is within "A" range as illustrated.

Clutch pedal height "A"	148 – 154 mm (5.83 – 6.06 in.)
-------------------------	-----------------------------------

If clutch pedal height is out of above specification, adjust it by turning pedal stopper bolt. Be sure to tighten lock nut after adjustment.

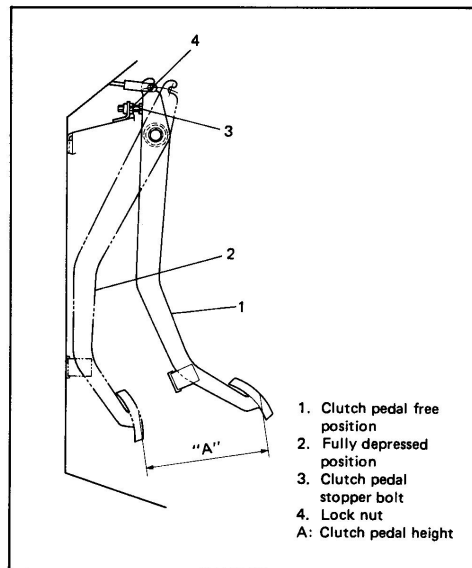

SECTION 15

PROPELLER SHAFTS

NOTE:

For the items not found in this section, refer to the same section of '88 MODEL SERVICE MANUAL.

CONTENTS

15-5. TIGHTENING TORQUE..... 15-1

15-5. TIGHTENING TORQUE

Bolts & Nuts

Check following bolts and nuts for tightness and retighten them as necessary:

Tightening torque for propeller shaft (Universal joint flange) bolts and nuts	N-m	kg-m	lb-ft
	50 – 60	5.0 – 6.0	36.5 – 43.0

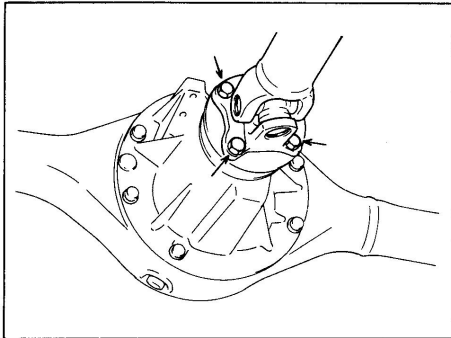

SECTION 19

BRAKES

NOTE:

For the items not found in this section, refer to the same section of '88 MODEL SERVICE MANUAL.

CONTENTS

19-1. GENERAL DESCRIPTION	19-2
19-4. MASTER CYLINDER	19-9
19-5. BRAKE BOOSTER	19-12
19-7. BRAKE PIPES AND HOSES	19-24
19-10. SPECIAL TOOLS	19-26

NOTE:

All brake fasteners are important attaching parts in that they could affect the performance of vital parts and systems, and/or could result in major repair expense. They must be replaced with one of same part number or with an equivalent part if replacement becomes necessary. Do not use a replacement part of lesser quality or substitute design. Torque values must be used as specified during reassembly to assure proper retention of all parts. There is to be no welding as it may result in extensive damage and weakening of the metal.

19

WARNING:

When servicing wheel brake parts, do not create dust by grinding, sanding brake linings, or by cleaning wheel brake parts with a dry brush or with compressed air. Many wheel brake parts contain asbestos fibers which can become airborne if dust is created during servicing. Breathing dust containing asbestos fibers may cause serious bodily harm. A water dampened cloth or water based solution should be used to remove any dust on brake parts. Equipment is commercially available to perform this washing function. These wet methods will prevent asbestos fibers from becoming airborne.

19-1

19-1. GENERAL DESCRIPTION

When the foot brake pedal is depressed, hydraulic pressure is developed in the master cylinder to actuate pistons (two in front and four in rear).

The master cylinder is a tandem master cylinder. Two brake pipes are connected to the master cylinder and they make two independent circuits. One connects the front brakes (right & left) and the other connects the rear brakes (right & left).

The proportioning and bypass valve (P & B valve) is included within the brake circuit which connects the master cylinder and the rear wheel brake.

In this brake system, the disc brake type is used for the front wheel brake and a drum brake type (leading/trailing shoes) for the rear wheel brake.

The parking brake system is mechanical. It applies brake force to only rear wheels by means of the cable and mechanical linkage system. The same brake shoes are used for both parking and foot brakes.

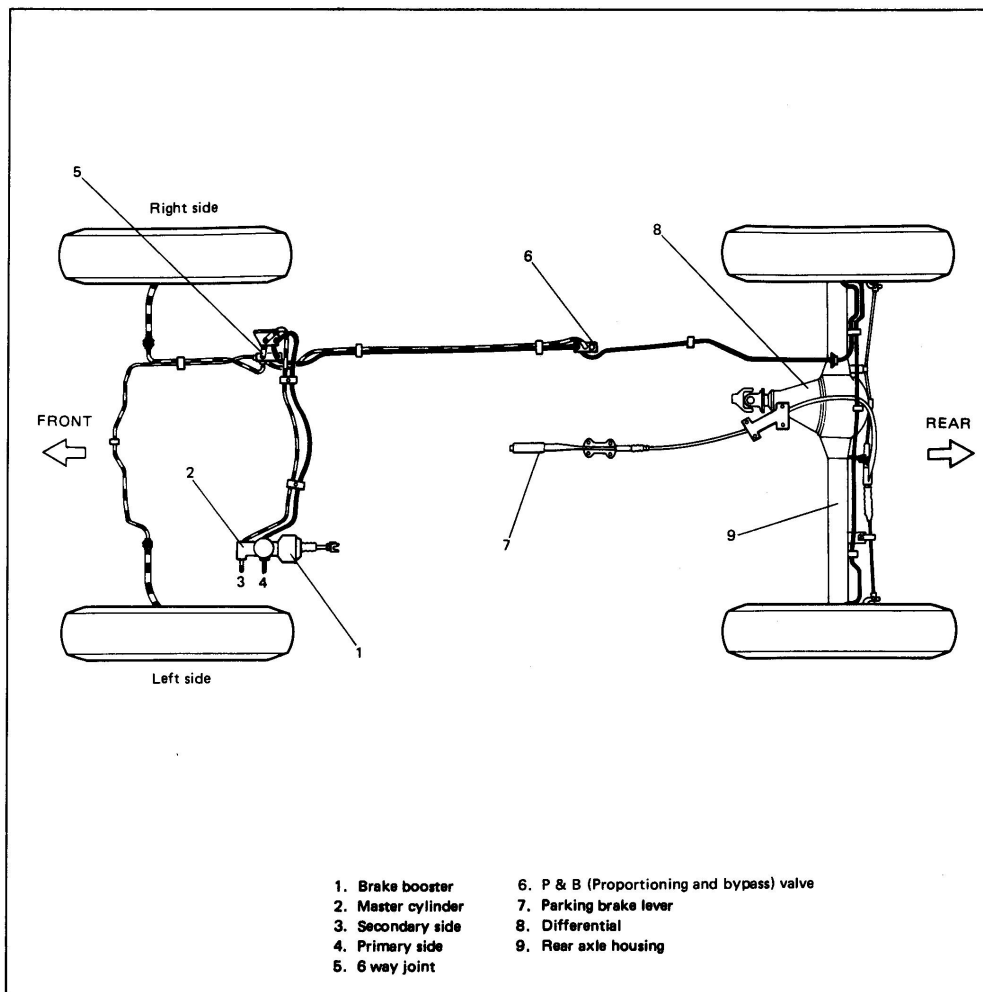
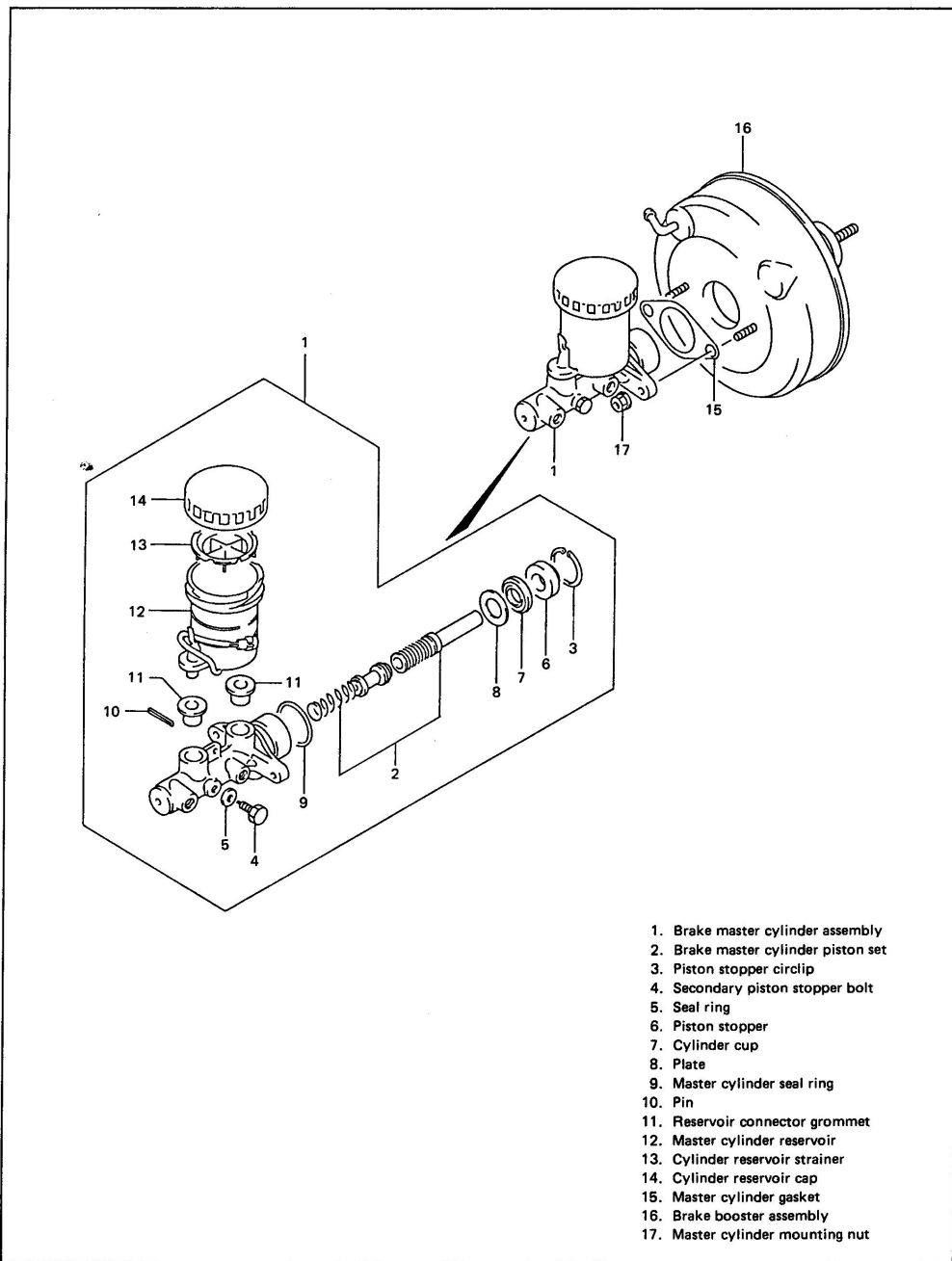

Fig. 19-1

19-2

MASTER CYLINDER



- 1. Brake master cylinder assembly
- 2. Brake master cylinder piston set
- 3. Piston stopper circlip
- 4. Secondary piston stopper bolt
- 5. Seal ring
- 6. Piston stopper
- 7. Cylinder cup
- 8. Plate
- 9. Master cylinder seal ring
- 10. Pin
- 11. Reservoir connector grommet
- 12. Master cylinder reservoir
- 13. Cylinder reservoir strainer
- 14. Cylinder reservoir cap
- 15. Master cylinder gasket
- 16. Brake booster assembly
- 17. Master cylinder mounting nut

Fig. 19-2

MASTER CYLINDER ASSEMBLY

[GENERAL DESCRIPTION]

The master cylinder has two pistons and three piston cups. Its hydraulic pressure is produced in the primary ("a" in the below figure) and secondary ("b") chambers. The hydraulic pressure produced in the primary chamber ("a") acts on the rear wheel brakes (right & left).

Also, the hydraulic pressure produced in the secondary chamber ("b") acts on the front wheel brakes (right & left).

NOTE:

Replace all components included in repair kits to service this master cylinder. Lubricate rubber parts with clean, fresh brake fluid to ease assembly. Do not use lubricated shop air on brake parts as damage to rubber components may result. If any hydraulic component is removed or brake line disconnected, bleed the brake system. The torque values specified are for dry, unlubricated fasteners.

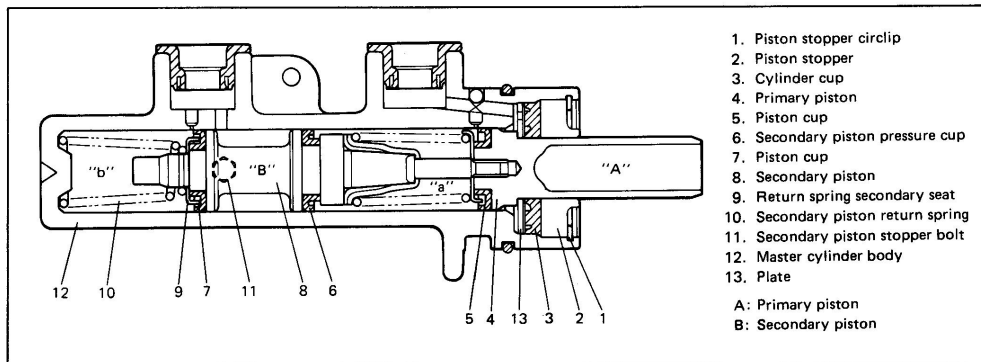

Fig. 19-3

[Master cylinder OPERATION]

Normal operation

Depressing the brake pedal forces the primary piston "A" to move to the left in the below figure and consequently the hydraulic pressure is produced in the chamber "a".

By means of this pressure and the return spring force, the secondary piston "B" is also pushed to the left and thus the hydraulic pressure is produced in the chamber "b".

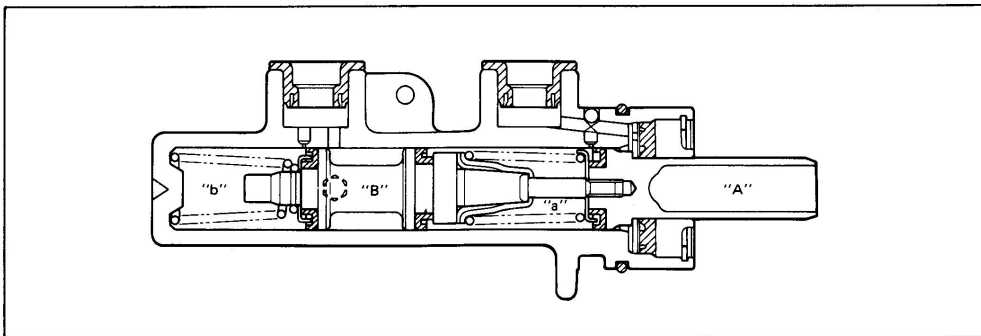

Fig. 19-3-1

One-circuit operation (Primary chamber "a" circuit failure)

Depressing the brake pedal forces the primary piston "A" to move as described previously, but since the brake circuit connected to the chamber "a" cannot hold the pressure, no pressure is produced in the fluid immediately ahead of the piston "A". The piston "A" keeps moving while compressing the spring and when it reaches the retainer, the piston "B" is pushed and begins to move. This causes the pressure to rise in the chamber "b" and the pressure acts on front wheel brakes (right & left).

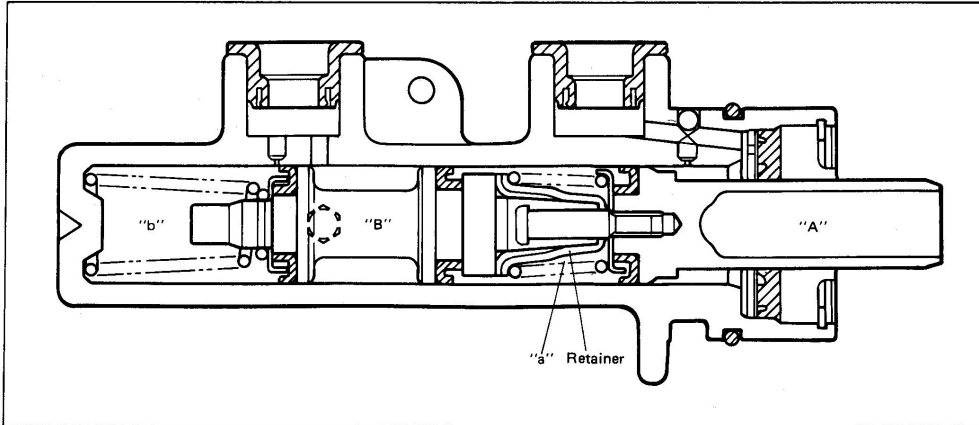

Fig. 19-4

One-circuit operation (Secondary chamber "b" circuit failure)

In this case, the leftward movement of the piston "A" has but little effect in causing the fluid pressure to rise in the chamber "a" in the beginning, because the initial rise of the fluid pressure causes the piston "B" to promptly yield and move to the left. However, when the forward end of the piston "B" comes to the head of the cylinder and stops there, the leftward movement of the piston "A" becomes effective. Thus the fluid pressure is produced in the chamber "a" and it acts on rear wheel brakes (right & left). The below figure shows secondary piston "B" at halt.

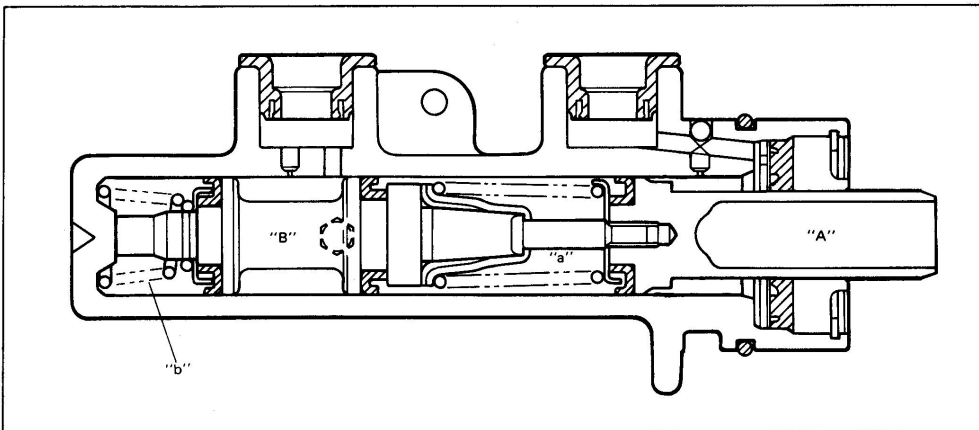

Fig. 19-4-1

[Booster OPERATION]

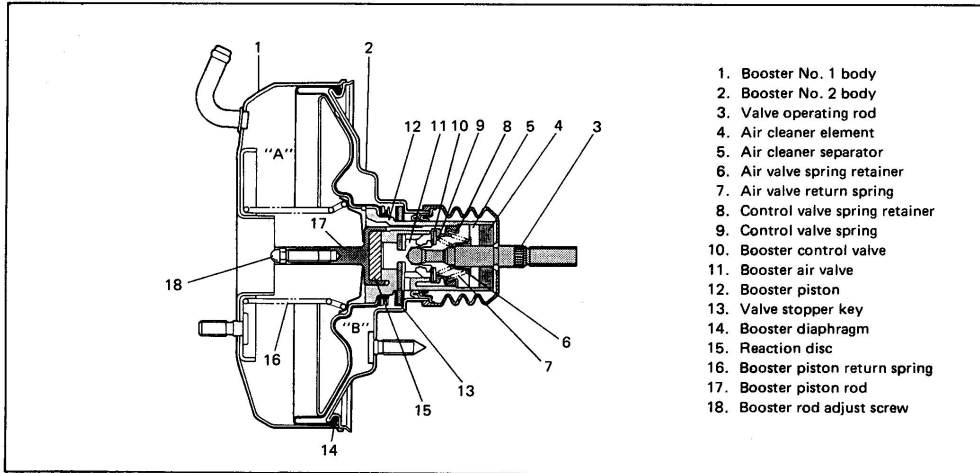

Fig. 19-13-1 Vacuum Booster Assembly

When the brake pedal is depressed, the force is transmitted to the piston of the master cylinder through the valve operating rod, booster air valve, reaction disc and piston rod. At the same time, the force of the booster piston developed due to the pressure difference between the two chambers "A" and "B" in the above figure is added to it.

The end of the booster control valve has a double function of a vacuum valve and air valve. That is, as shown in the figure, the booster control valve closes between the "A" and "B" chambers as its outer end "C" contacts the booster piston seat and opens as "C" leaves the booster piston seat (vacuum valve function). Also it closes between the "B" chamber and outside air as its inner end "D" contacts the air valve seat and opens as "D" leaves the air valve seat (air valve function).

When foot brake pedal is not depressed

The valve operating rod is pushed to the right by the spring force as shown. The air valve is also enough to the right to contact the valve stopper key as shown. In this state, the vacuum valve (control valve "C") is open and the air valve (control valve "D") is closed. Thus the chambers "A" and "B" conduct and share the same negative pressure (because of no pressure difference) which allows the return spring to push the booster piston to the right.

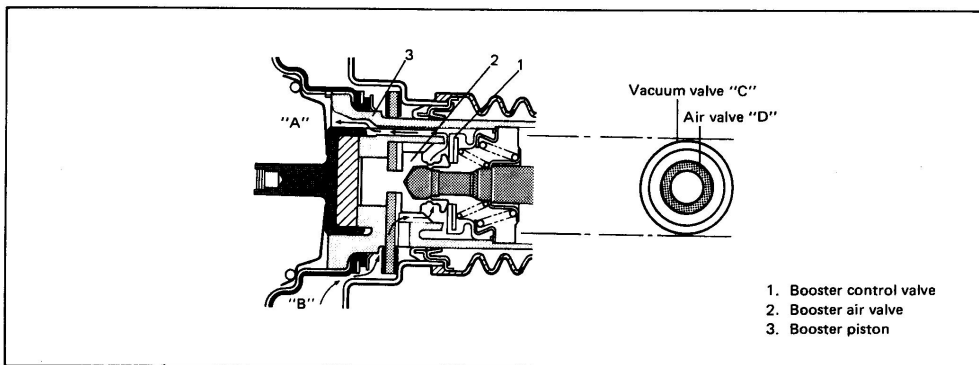

Fig. 19-13-2 Vacuum Booster Assembly

When foot brake pedal is depressed

Being pushed by the operating rod, the booster air valve moves to the left as shown. Then the control valve is pushed against the booster piston seat closely by the valve spring force. Thus the vacuum valve (control valve "C") is closed to cut off between the chambers "A" and "B". At this time the air valve (control valve "D") is still closed.

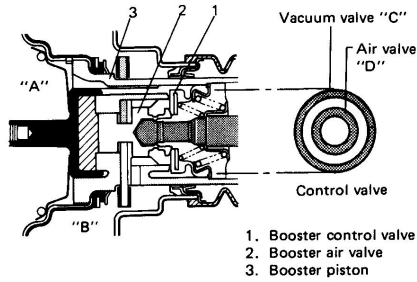

Fig. 19-14-1

As the booster air valve moves further to the left, it leaves the control valve and the air valve (control valve "D") opens to allow the air to flow into the chamber "B". The entry of air causes a difference in pressures between the chambers "A" and "B". When this pressure difference grows greater than the piston return spring force, the booster piston moves to the left and the booster control valve also moves to the left. The resulting air valve (control valve "D") closure stops the air flow into the chamber "B" and its pressure remains as it is. In this way, a small brake pedal depressing force is made into a strong push to the master cylinder push rod to produce high hydraulic pressure.

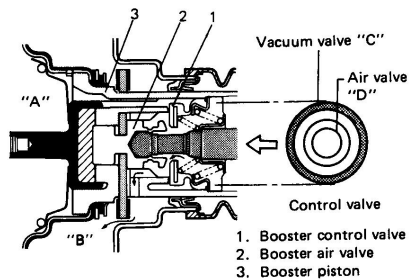

Fig. 19-14-2

19-8

When foot brake pedal is released

When the brake pedal is released, the booster air valve returns to the right by the master cylinder piston return force and the air valve return spring force as shown. Then the vacuum valve (control valve "C") opens and causes negative pressure in the chamber "B". The result is that the master cylinder piston and booster piston return to their original positions. This is the same state as described under "When foot brake pedal is not depressed".

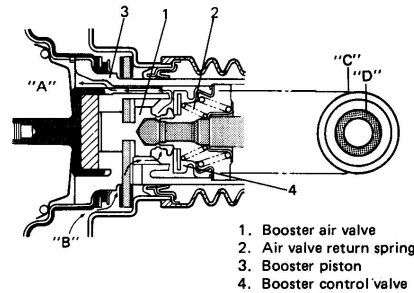

Fig. 19-14-3

Reference

Should any of the vacuum related parts in the booster be faulty, the brake force is not increased. Even then, however, the brake depressing force is transmitted to the valve operating rod, booster air valve, valve stopper key and booster piston in that order, to push the master cylinder push rod. Thus, the braking operation itself will not fail.

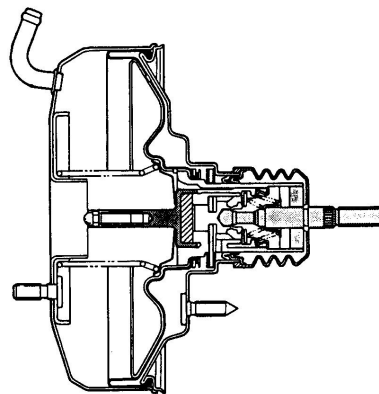
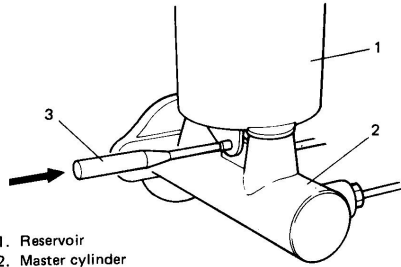

Fig. 19-14-4

19-4. MASTER CYLINDER

REMOVAL

- 1) Remove air cleaner case. (For right hand steering vehicle)
- 2) Disconnect reservoir lead wire at coupler.
- 3) Clean outside of reservoir.
- 4) Take out fluid with syringe or such.
- 5) Remove reservoir connector pin by using special tool.



1. Reservoir
2. Master cylinder
3. Special tool
(Connector pin remover
09922-85811)

Fig. 19-56

- 6) Remove reservoir.
- 7) Disconnect two brake pipes from master cylinder.

NOTE:

Do not allow brake fluid to get on painted surfaces.

- 8) Remove master cylinder mounting nuts.
- 9) Remove master cylinder.

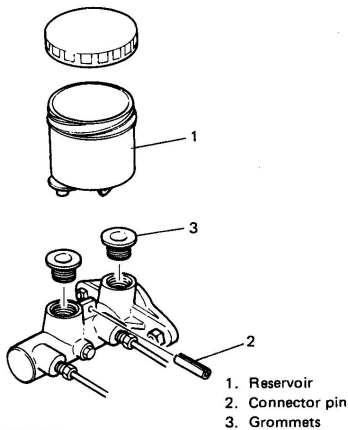
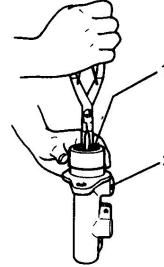

Fig. 19-56-1

DISASSEMBLY

- 1) Remove circlip.
- 2) Remove primary piston.



1. Circlip
2. Master cylinder

Fig. 19-57

- 3) Remove piston stopper bolt. Then remove secondary piston by blowing compressed air into hole from which piston stopper bolt was removed.

Be cautious during removal as secondary piston jumps out.

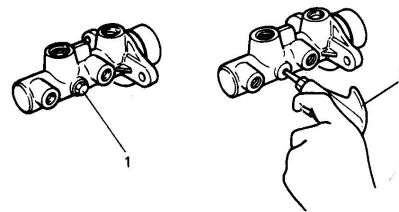

1. Stopper bolt
2. Compressed air

Fig. 19-58

INSPECTION OF COMPONENTS

Master Cylinder Inner Parts

Inspect all disassembled parts for wear or damage, and replace parts if necessary.

NOTE:

- Wash disassembled parts with brake fluid.
- Do not reuse piston cups.

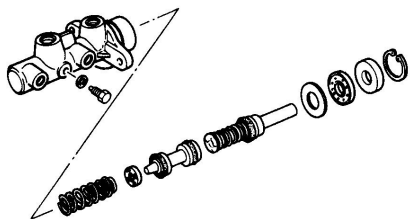

Fig. 19-59

Inspect master cylinder bore for scoring or corrosion. It is best to replace a corroded cylinder. Corrosion can be identified as pits or excessive roughness.

NOTE:

Polishing bore of master cylinder with cast aluminum body with anything abrasive is prohibited, as damage to cylinder bore may occur.

Rinse cylinder in clean brake fluid. Shake excess rinsing fluid from cylinder. Do not use a cloth to dry cylinder, as lint from cloth will remain on cylinder bore surface.

Reservoir

NOTE:

Do not use shock absorber fluid or any other fluid which contains mineral oil. Do not use a container which has been used for mineral oil or a container which is wet from water. Mineral oil will cause swelling and distortion of rubber parts in the hydraulic brake system and water will mix with brake fluid, lowering the fluid boiling point. Keep all fluid containers capped to prevent contamination.

Fluid to fill reservoir with is indicated on reservoir cap of the vehicle with embossed letters or in owner's manual supplied with the vehicle. Add fluid up to MAX line.

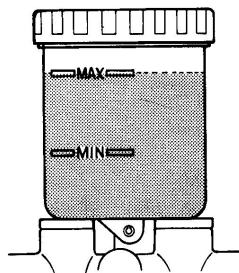

Fig. 19-60

ASSEMBLY

NOTE:

Before assembling, wash each part in fluid recommended to use for that vehicle.

- 1) Assemble secondary piston as shown below.
- 2) Install secondary piston assembly into cylinder.

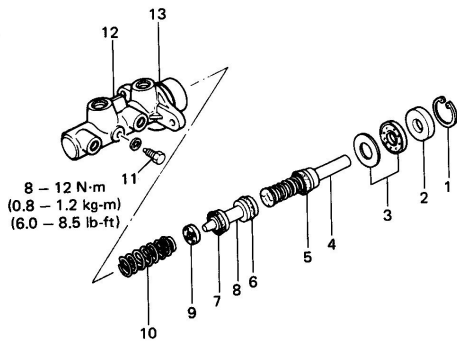

- | | |
|----------------------------------|------------------------------------|
| 1. Piston stopper circlip | 7. Piston cup |
| 2. Piston stopper | 8. Secondary piston |
| 3. Cylinder cup and plate | 9. Return spring secondary seat |
| 4. Primary piston | 10. Secondary piston return spring |
| 5. Piston cup | 11. Secondary piston stopper bolt |
| 6. Secondary piston pressure cup | 12. Master cylinder body |
| | 13. Sealing |

Fig. 19-61

- 3) Install primary piston in cylinder.
- 4) Depress, and install circlip.

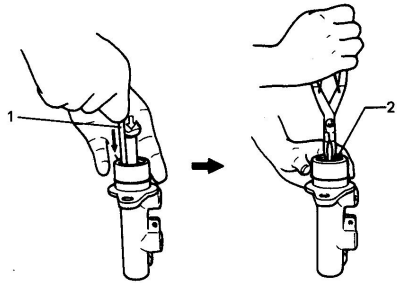

Fig. 19-62

- 5) Install piston stopper bolt with pistons pushed in all the way and tighten it to specified torque.
- 6) For installation on vehicle, refer to INSTALLATION.

PRECAUTION OF INSTALLATION

NOTE:

Adjust clearance between booster piston rod and primary piston with special tool (See page 19-20).

- 1) Install master cylinder as shown and torque attaching nuts to specification.
- 2) Connect 2 hydraulic lines and torque flare nuts to specification.
- 3) When using new grommets, lubricate them with the same fluid as the one to fill reservoir with. Then press-fit grommets to master cylinder. Grommets must be seated in place.
- 4) Install reservoir and drive in reservoir pin.

NOTE:

Drive in reservoir pin till both of its ends at the right and left of reservoir become the same length.

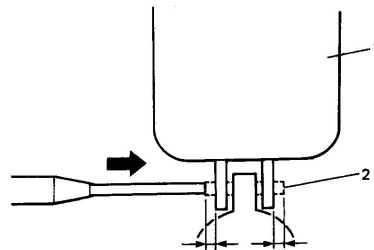

1. Reservoir
2. Pin

Fig. 19-63

- 5) Connect reservoir lead wire.
- 6) Fill reservoir with specified fluid.
- 7) Upon completion of installation, check for fluid leakage.

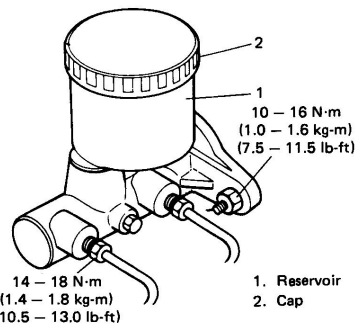

Fig. 19-64

19-5. BRAKE BOOSTER

REMOVAL

- 1) Remove master cylinder assembly, referring to steps 1) – 4) and 7) – 9) of its REMOVAL on page 19-9.
- 2) Disconnect vacuum hose from booster.
- 3) Disconnect push rod clevis from brake pedal arm.
- 4) Remove attaching nuts and then booster as shown.

INSTALLATION

NOTE:

- Adjust clearance between booster piston rod and master cylinder piston with special tool. (See page 19-20.)
- Check length of push rod clevis. (See page 19-19.)

- 1) Install booster to dash panel as shown. Then connect booster-push rod clevis to pedal arm with clevis pin and split pin.
- 2) Torque booster attaching nuts to specification.
- 3) Install master cylinder to booster and torque master cylinder mounting nuts to specification.
- 4) Connect two brake pipes and torque flare nuts to specification.
- 5) Connect booster vacuum hose.
- 6) Connect reservoir lead wire at coupler.
- 7) Install air cleaner case.
- 8) Fill reservoir with specified fluid.
- 9) Bleed air from brake system.
- 10) After installing, check pedal height and play.
- 11) Perform brake test and check each installed part for fluid leakage.

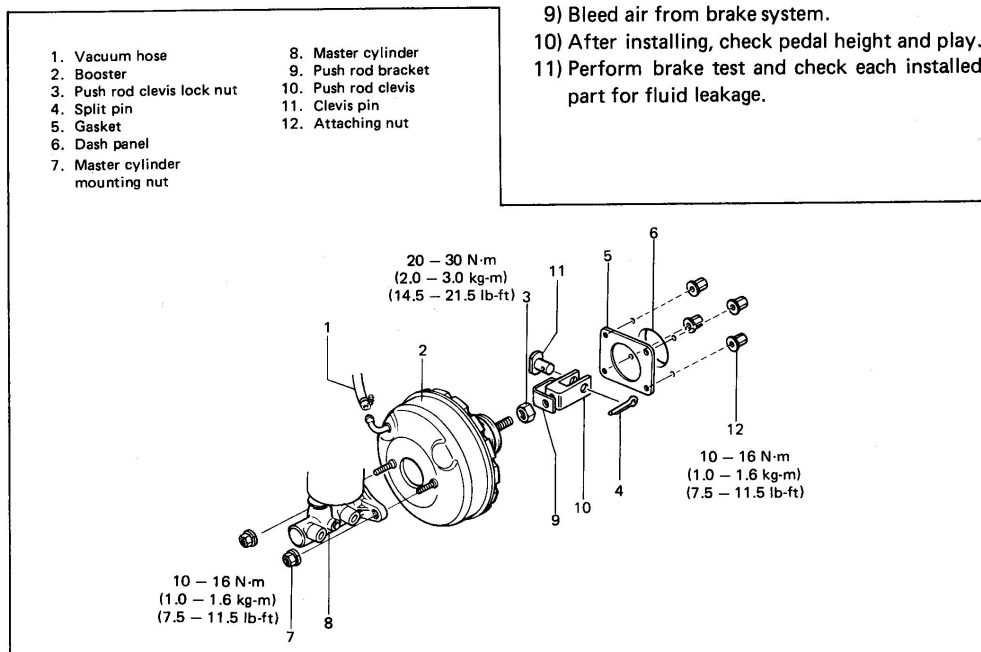

Fig. 19-65

DISASSEMBLY

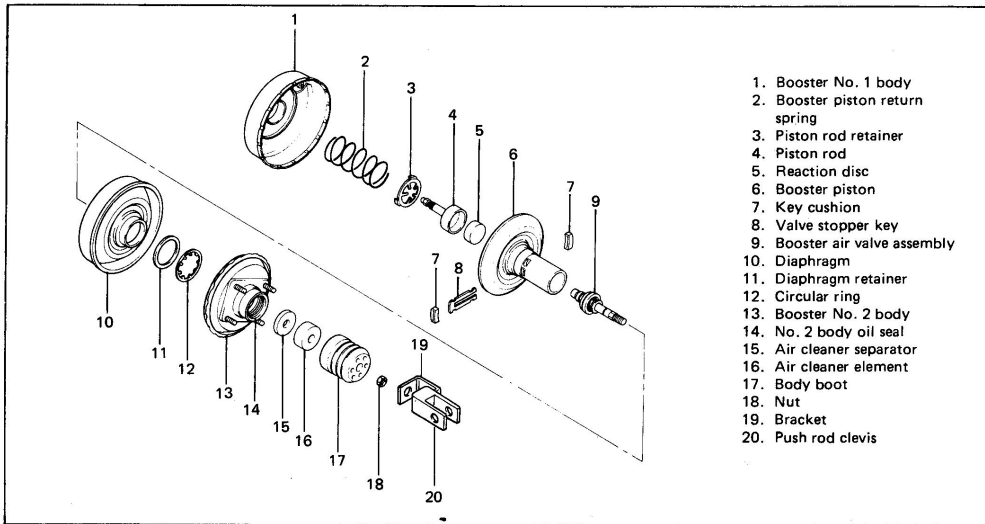

Fig. 19-66

1) Remove push rod clevis and nut.

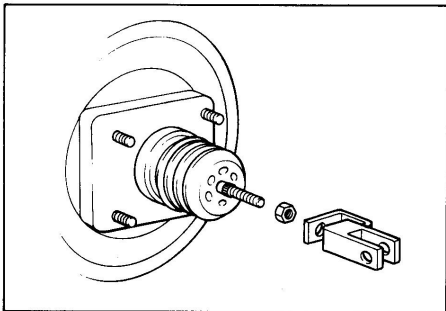

Fig. 19-67

2) Attach booster to special tool (A) as shown and install special tool (B) to booster as shown.

NOTE:

- When attaching, check to be sure that booster vacuum pipe is not in faulty contact with base of special tool (A).
- Be careful not to over-tighten nuts, or booster body will be deformed.

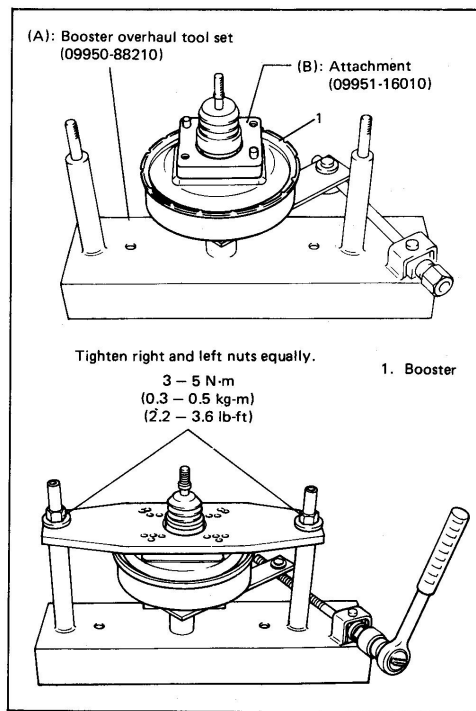

Fig. 19-68

- 3) Turn special tool bolt clockwise until No. 1 body projecting part and No. 2 body depressed part fit each other. Once they are matched, make match marking on No. 1 and No. 2 bodies to facilitate their installation.

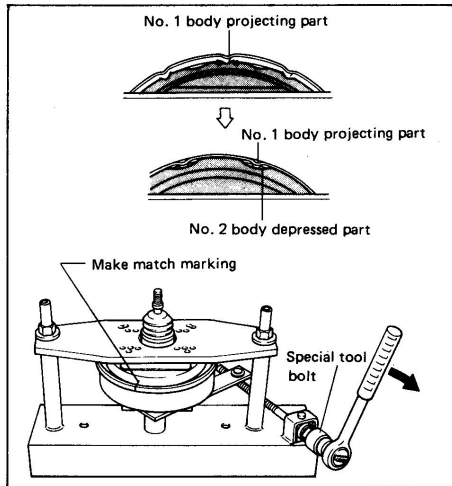

Fig. 19-69

- 4) Detach booster from special tool and separate No. 1 body and No. 2 body. Remove piston return spring.

WARNING:

When separating two bodies, carefully hold both bodies to prevent either body from jumping off by spring force.

- 5) From booster No. 2 body, remove piston rod, boot, air cleaner element and air cleaner separator in this order.

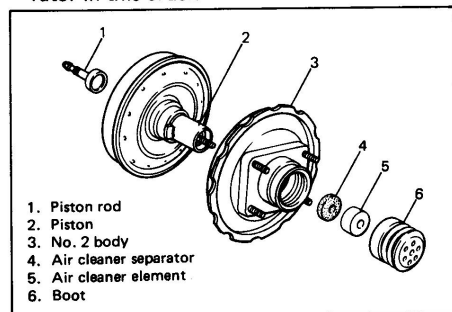

Fig. 19-70

19-14

- 6) Remove valve stopper key cushion from stopper key.

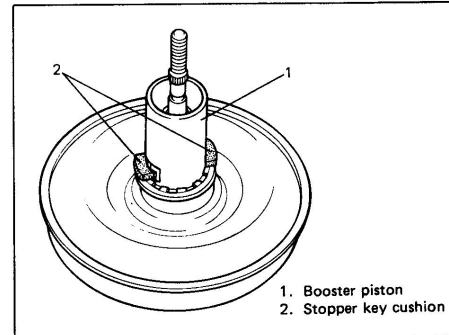

Fig. 19-71

- 7) While compressing air valve spring (by moving rod up and down as shown), remove valve stopper key. Then remove booster air valve assembly from booster piston.

NOTE:

Booster air valve assembly can't be disassembled.

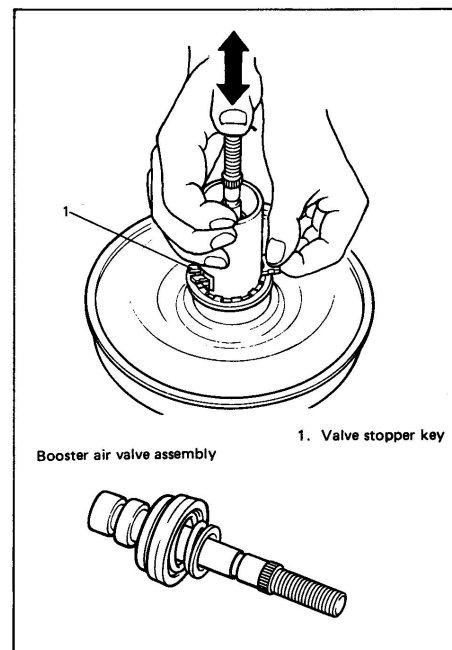

Fig. 19-72

8) Remove diaphragm circular ring from booster piston.

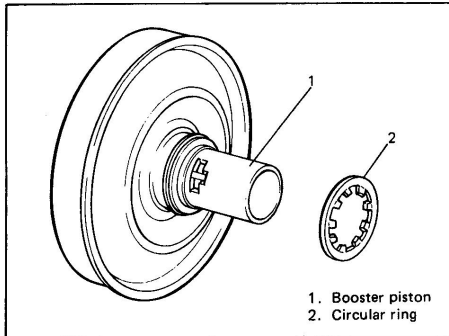

Fig. 19-72-1

10) Remove reaction disc from booster piston rod.

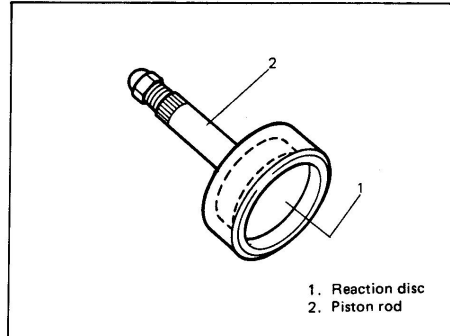

Fig. 19-74

9) Remove diaphragm from booster piston.

NOTE:

Don't use driver or other tool for removal. Pull it off by hand carefully handling piston groove area where diaphragm is fitted.

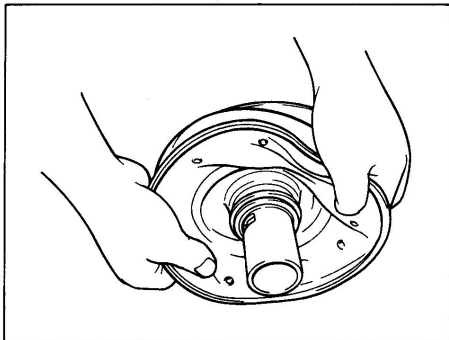

Fig. 19-73

11) Remove oil seal from booster No. 2 body with special tools as shown.

NOTE:

Removed oil seal must not be reused.

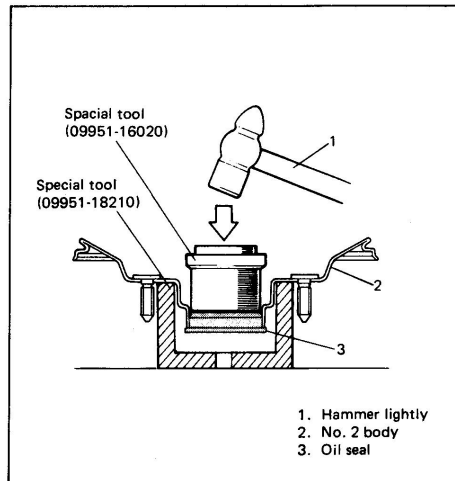

Fig. 19-75

ASSEMBLY

NOTE:

Be sure to use silicon grease wherever application of grease is instructed during assembly.

- 1) Apply grease to new oil seal outer surface and oil seal lip as shown.
Press-fit new oil seal to booster No. 2 body by using special tools (C) and (D).

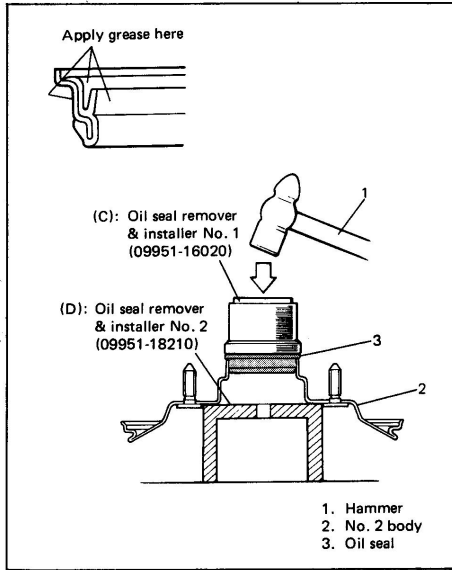

Fig. 19-76

- 2) Install retainer to diaphragm.

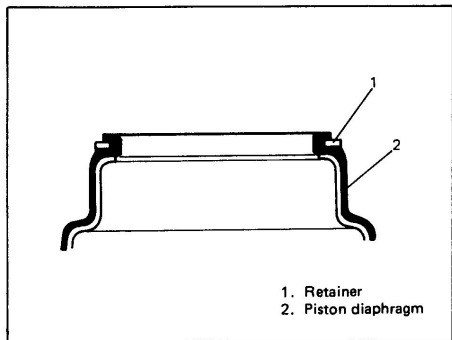

Fig. 19-77

- 3) Install diaphragm to booster piston by hand.

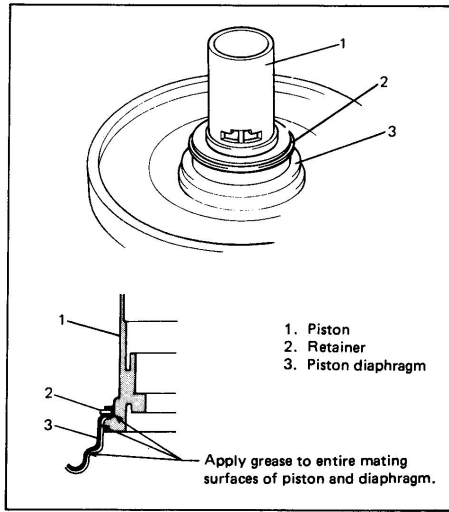

Fig. 19-78

- 4) Install new diaphragm circular ring, referring to figure below for its proper installing direction.

NOTE:

Be careful not to cause damage to piston when installing.

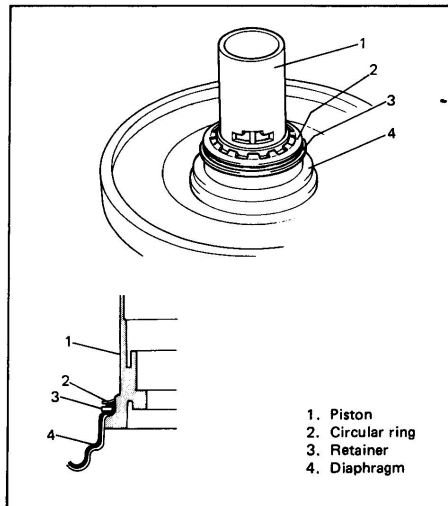

Fig. 19-79

5) Install booster air valve assembly to booster piston. Before installation, apply grease as shown.

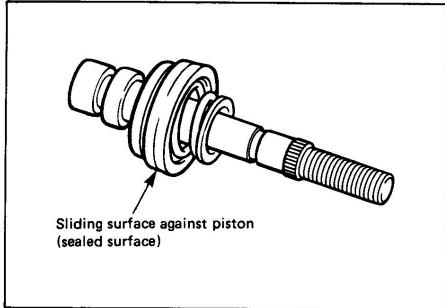

Fig. 19-80

6) Compress air valve assembly and insert valve stopper key.

NOTE:
Don't compress air valve assembly forcibly.

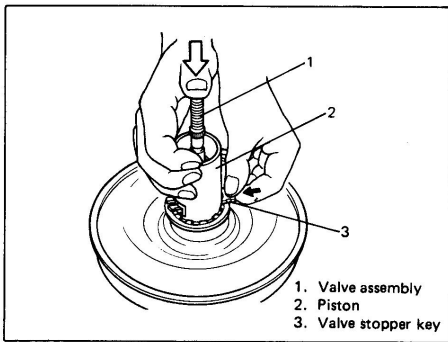

Fig. 19-81

7) Install valve stopper key cushions.

NOTE:
Make sure that it is installed in proper direction and cushion is fitted to notch in key.

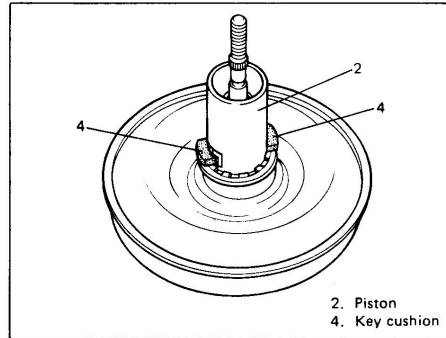

Fig. 19-82

8) Install booster piston to booster No. 2 body.

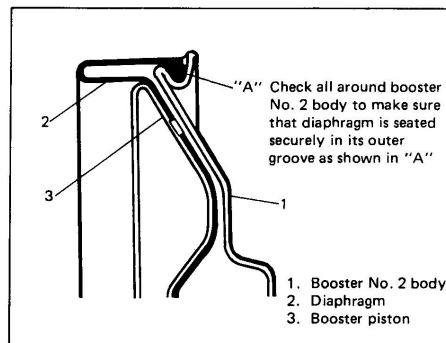

Fig. 19-83

9) Install air cleaner separator and then element to rod of air valve assembly.
10) Install body boot to booster No. 2 body. Both ends of boot must be fitted securely as shown.

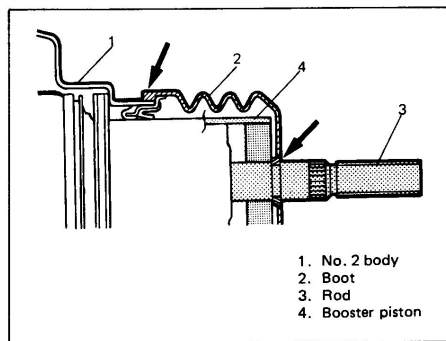

Fig. 19-84

11) Install reaction disc to booster piston rod after greasing its outer face.

NOTE:

Make sure that no air exists between piston rod and reaction disc.

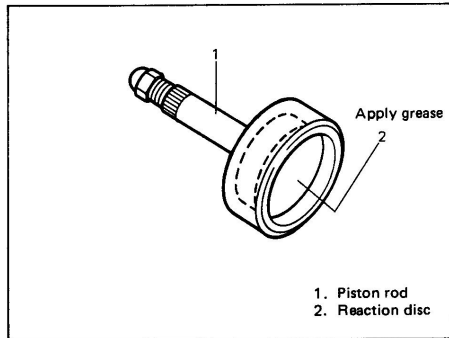

Fig. 19-85

12) Place No. 1 body on special tool (A).

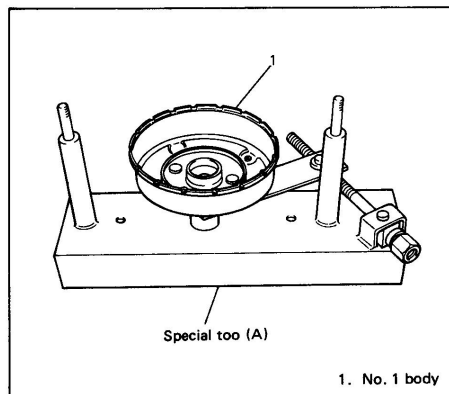

Fig. 19-86

13) Install piston rod, rod retainer and piston return spring to booster piston as shown below. Then install them to booster No. 1 body.

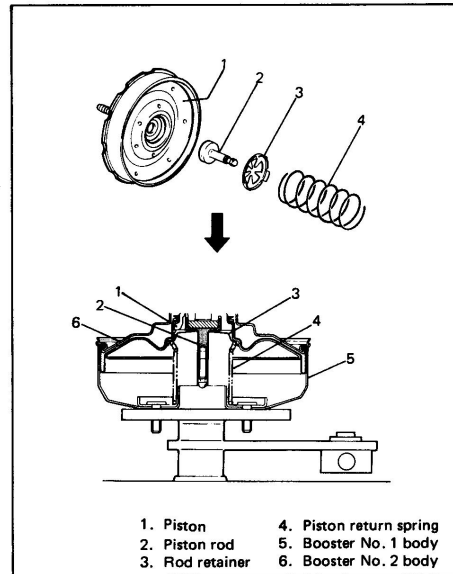

Fig. 19-87

14) Put No. 1 and No. 2 bodies together by aligning markings made before disassembly. Holding No. 2 body with upper plate (special tool) as shown, torque two nuts equally to specification.

Special tool nuts tightening torque	N·m	kg·m	lb·ft
	3 - 5	0.3 - 0.5	2.2 - 3.6

NOTE:

When holding No. 2 body, use care so that diaphragm is not caught by projections at 16 locations around No. 1 body.

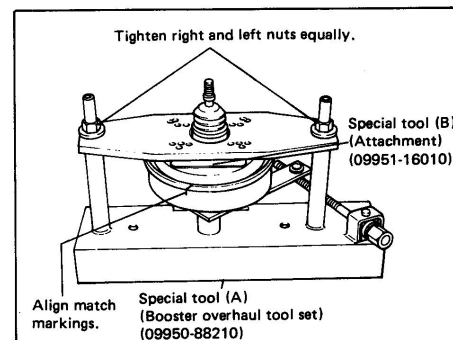

Fig. 19-88

- 15) Turn special tool bolt counterclockwise until No. 1 body projecting part comes to mid-position of No. 2 body depressed parts as shown.

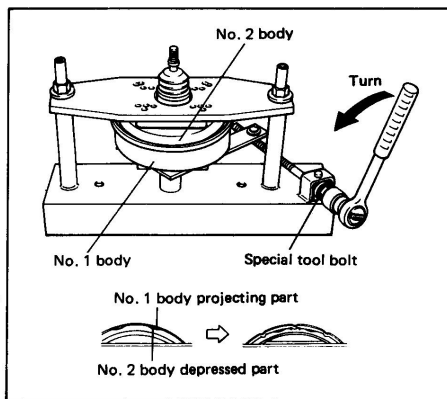

Fig. 19-89

- 16) Install push rod clevis so that below measurement "A" is obtained and torque nut to specification.

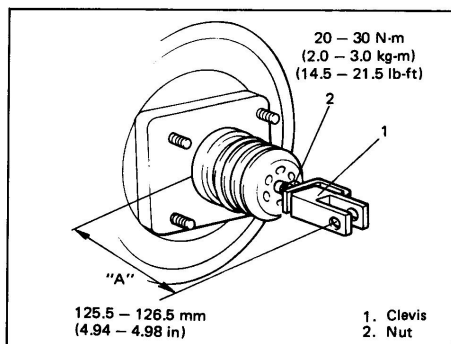

Fig. 19-90

- 17) Remove booster from special tool.

NOTE:

Whenever booster was disassembled, make sure to check clearance between piston rod and master cylinder piston after reassembly. (For details, refer to page 19-20.)

- 18) For installation of booster, see steps 1) to 11) of its INSTALLATION on page 19-12.

INSPECTION

1. INSPECT BOOSTER INNER PARTS

NOTE:

After disassembly, soak all metal parts in ethyl alcohol. Wipe rubber diaphragm and plastic parts with a clean cloth. Use ethyl alcohol damped cloth to wipe out heavy dirt. Application of much ethyl alcohol especially to rubber parts is prohibited.

RUBBER PARTS

Wipe fluid from rubber parts and carefully inspect each rubber part for cuts, nicks or other damage. These parts are key to air flow control. If there is any question as to serviceability of rubber parts, **REPLACE** them.

METAL PARTS

BADLY DAMAGED ITEMS, OR THOSE WHICH WOULD TAKE EXTENSIVE WORK OR TIME TO REPAIR, SHOULD BE REPLACED. IN CASE OF DOUBT, INSTALL NEW PARTS.

2. INSPECT/ADJUST CLEARANCE BETWEEN BOOSTER PISTON ROD AND MASTER CYLINDER PISTON

The length of booster piston rod is adjusted to provide specified clearance between piston rod end and master cylinder piston.

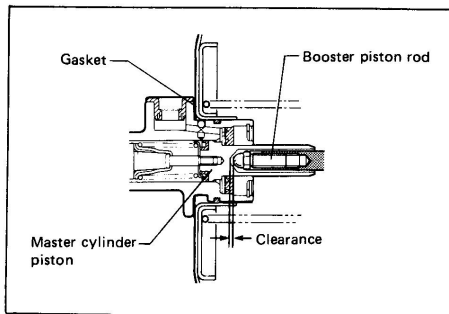

Fig. 19-91

- Before measuring clearance, push piston rod several times so as to make sure reaction disc is in place.

19-20

- Take measurement with gasket installed to master cylinder.
- Keep inside of booster at atmospheric pressure for measurement.

- 1) Set special tool (E) on master cylinder and push pin until contacts piston.

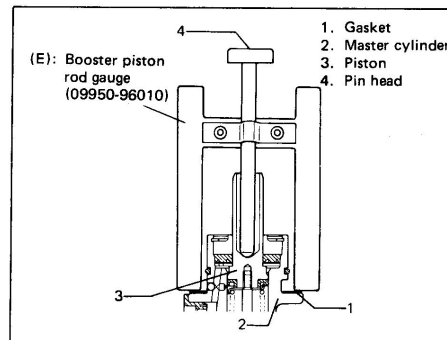

Fig. 19-92

- 2) Turn special tool upside down and place it on booster. Adjust booster piston rod length until rod end contacts pin head.
- 3) Adjust clearance by turning adjusting screw of piston rod.

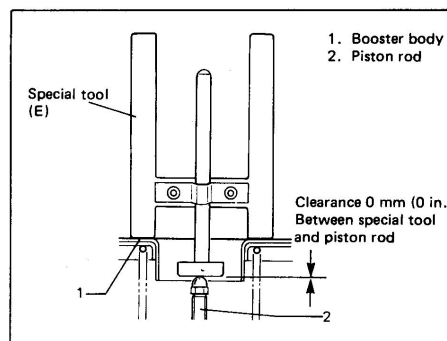

Fig. 19-93

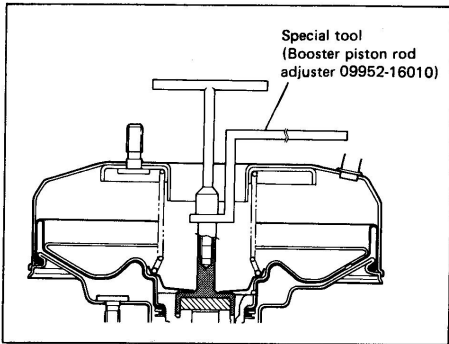

Fig. 19-94

Reference

- When adjusted as above, if negative pressure is applied to booster with engine at idle, piston to piston rod clearance should become 0.25 – 0.5 mm (0.010 – 0.020 in.).

3. INSPECT BOOSTER OPERATION

There are two ways to perform this inspection, with and without a tester. Ordinarily, it is possible to roughly determine its condition without using a tester.

NOTE:

For this check, make sure that no air is in hydraulic line.

INSPECTION WITHOUT TESTER

Check Air Tightness

- 1) Start engine.
- 2) Stop engine after running for 1 to 2 minutes.
- 3) Depress brake pedal several times with the same load as in ordinary braking and observe pedal travel. If pedal goes down deep the first time but its travel decreases as it is depressed the second and more times, air tightness is obtained.

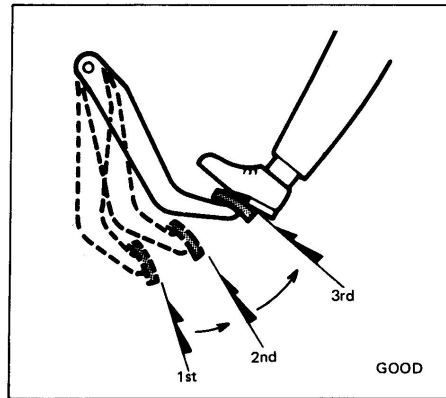

Fig. 19-95

- 4) If pedal travel doesn't change, air tightness isn't obtained.

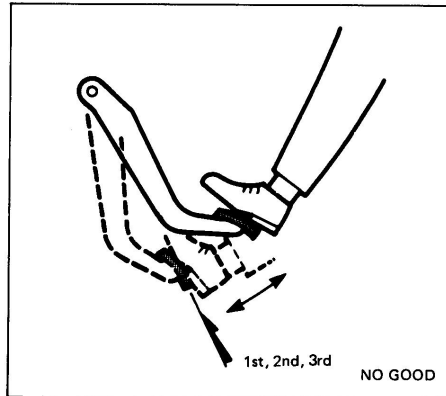

Fig. 19-96

NOTE:

If defective, inspect vacuum lines and sealing parts, and replace any faulty part. When this has been done, repeat the entire test!

Check Operation

1) With engine stopped, depress brake pedal several times with the same load and make sure that pedal travel doesn't change.

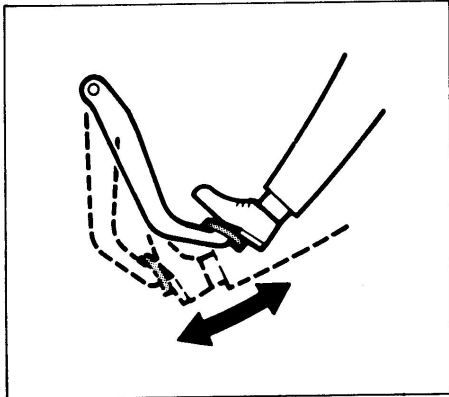

Fig. 19-97

Check Air Tightness Under Load

1) With engine running, depress brake pedal. Then stop engine while holding brake pedal depressed.

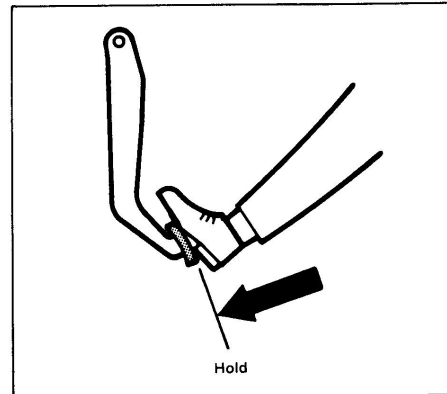

Fig. 19-99

2) Start engine while depressing brake pedal. If pedal travel increases a little, operation is satisfactory. But no change in pedal travel indicates malfunction.

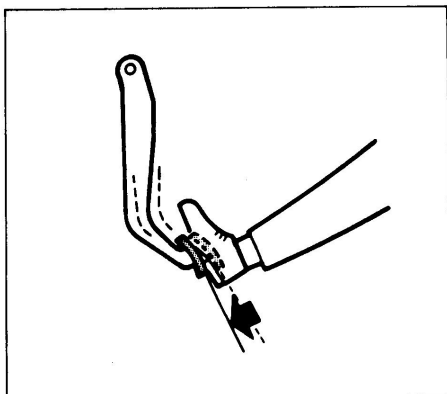

Fig. 19-98

2) Hold brake pedal depressed for 30 seconds. If pedal height does not change, condition is good. But it isn't if pedal rises.

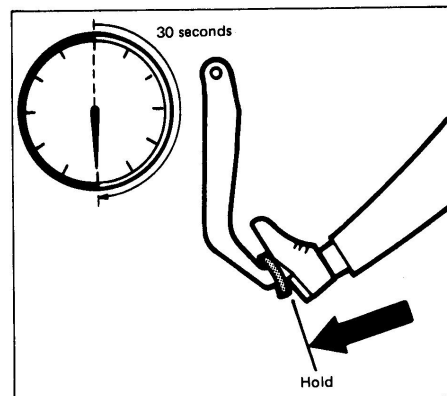
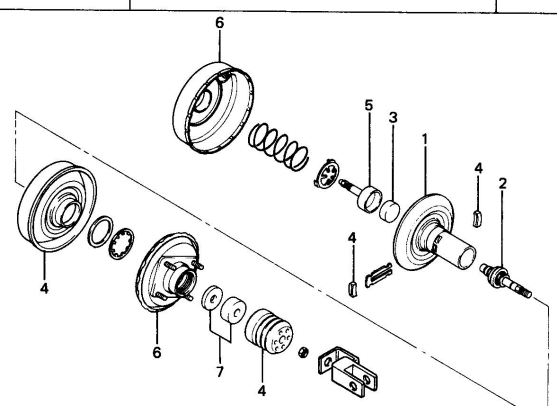

Fig. 19-100

4. BOOSTER INSPECTION TABLE

Part	Inspect For	Corrective Action
1. Booster piston	Cracks, distortion or damage.	Replace.
2. Air valve ass'y (Control valve and spring)	Damaged or worn seal surfaces.	Replace.
3. Reaction disc	Damage or wear.	Replace.
4. Diaphragm, boot and rubber	Damage.	Replace.
5. Piston rod	Damage or bend.	Replace.
6. Booster No. 1 & No. 2 body	<ol style="list-style-type: none"> 1. Scratches, scores, pits, dents, or other damage affecting rolling or sealing of diaphragm or other seals. 2. Cracks, damage at ears, damaged threads on studs. 3. Bent or nicked locking lugs. 4. Loose studs. 	<p>Replace, unless easily repaired.</p> <p>Replace, unless easily repaired.</p> <p>Replace, unless easily repaired.</p> <p>Replace.</p>
7. Air filters and separator	Dirt.	Replace.



The diagram shows an exploded view of a booster assembly. The components are numbered as follows: 1. Reaction disc, 2. Air valve assembly (control valve and spring), 3. Piston rod, 4. Diaphragm, boot and rubber, 5. Piston rod, 6. Booster No. 1 & No. 2 body, and 7. Air filters and separator. The diagram illustrates the relative positions and assembly sequence of these parts.

Fig. 19-101

19-7. BRAKE PIPES AND HOSES

NOTE:

For the service informations not found in this section, refer to the same section of '88 MODEL SERVICE MANUAL.

REMOVAL AND INSTALLATION

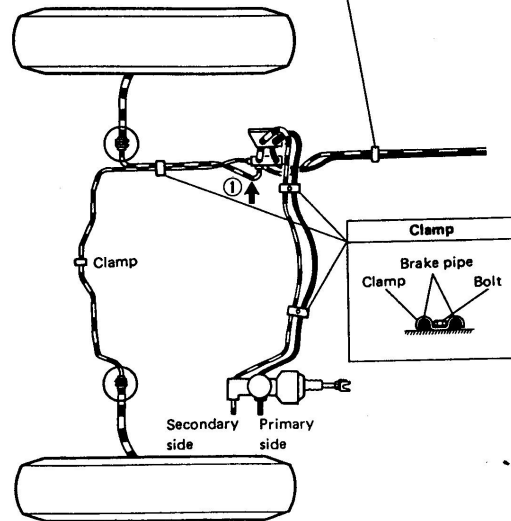
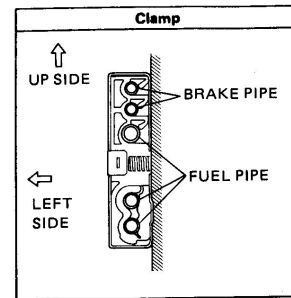
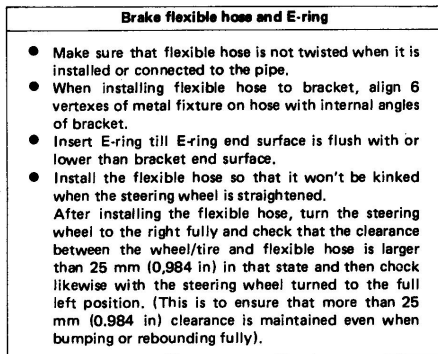
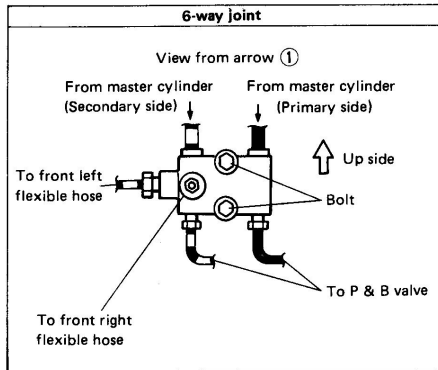

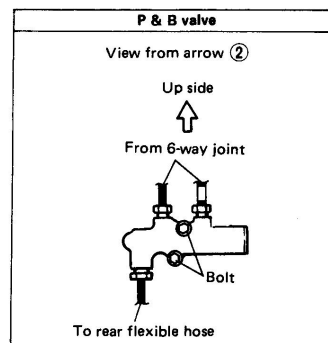
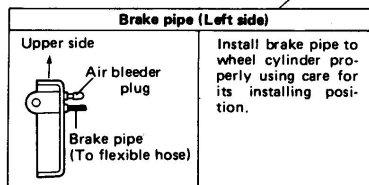
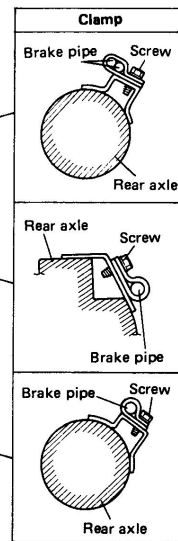
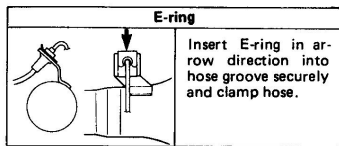
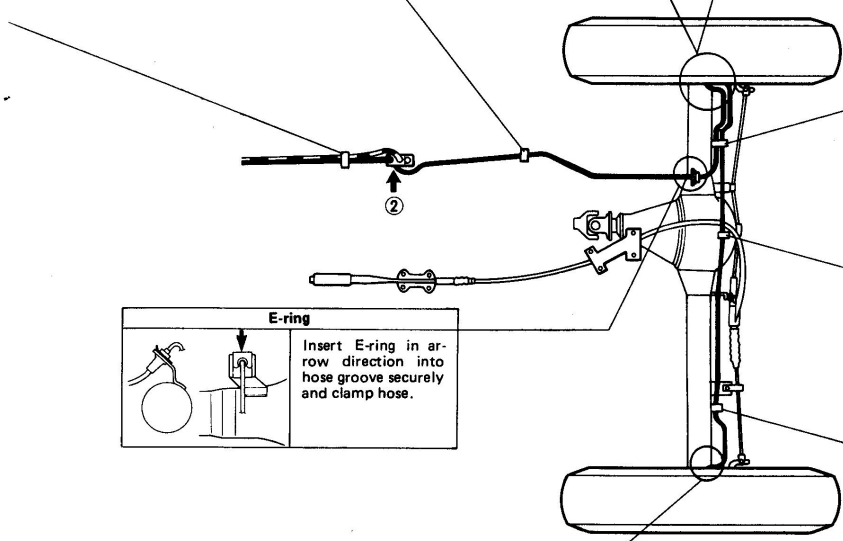
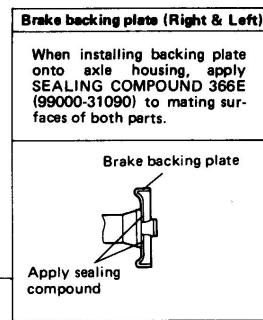
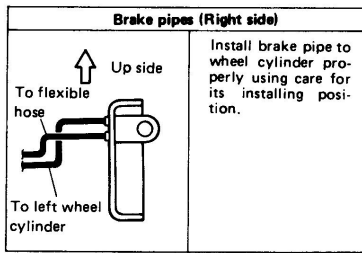
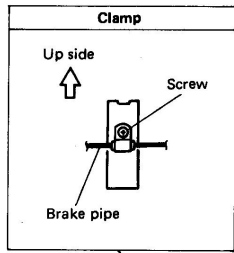



19-10. SPECIAL TOOLS

Shown below are special tools necessary when servicing brake system of '90 – '93 MODELS. The same ones are currently used for other models.

* : marked ones are used for SAMURAI '88 MODEL.

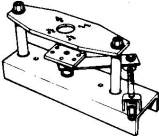
** : marked ones are used for SIDEKICK.

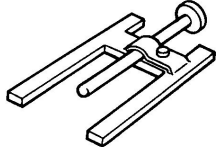
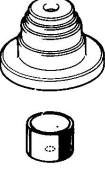
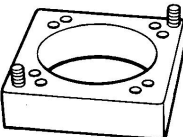
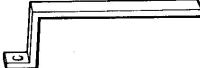
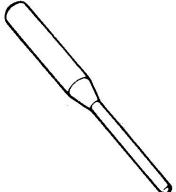
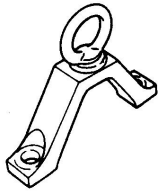
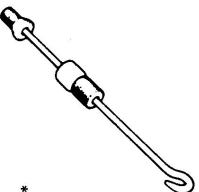
 <p>* 09950-88210 Booster overhaul tool set</p>	 <p>* 09950-78210 Flare nut wrench (10 mm)</p>	 <p>** 09950-96010 Booster piston rod gauge</p>	 <p>** No. 1 09951-16020 * No. 2 09951-18210 Booster No. 2 body Oil seal remover & Installer No. 1, No. 2</p>
 <p>** 09951-16010 Booster overhaul attachment</p>	 <p>** 09952-16010 Booster piston rod adjuster</p>	 <p>** 09922-85811 Connector pin remover</p>	 <p>* 09943-35511 Brake drum remover (Front wheel hub remover)</p>
 <p>* 09942-15510 Sliding hammer</p>			

SECTION 21

BODY ELECTRICAL EQUIPMENT

NOTE:

For the items not found in this section, refer to the same section of '88 MODEL SERVICE MANUAL.

CONTENTS

21- 1. COMBINATION METER	21-2
21-16. WIRING DIAGRAM .. Wiring diagrams are attached at the end of this manual.	
21-17. DAYTIME RUNNING LIGHT SYSTEM	21-3

21-1. COMBINATION METER

COMBINATION METER CIRCUIT

The '90-'93 model combination meter includes a vehicle speed sensor (VSS) in addition to the same components as the '88 model combination meter.

NOTE:

Whether equipped with *marked parts or not depends on vehicle specifications.

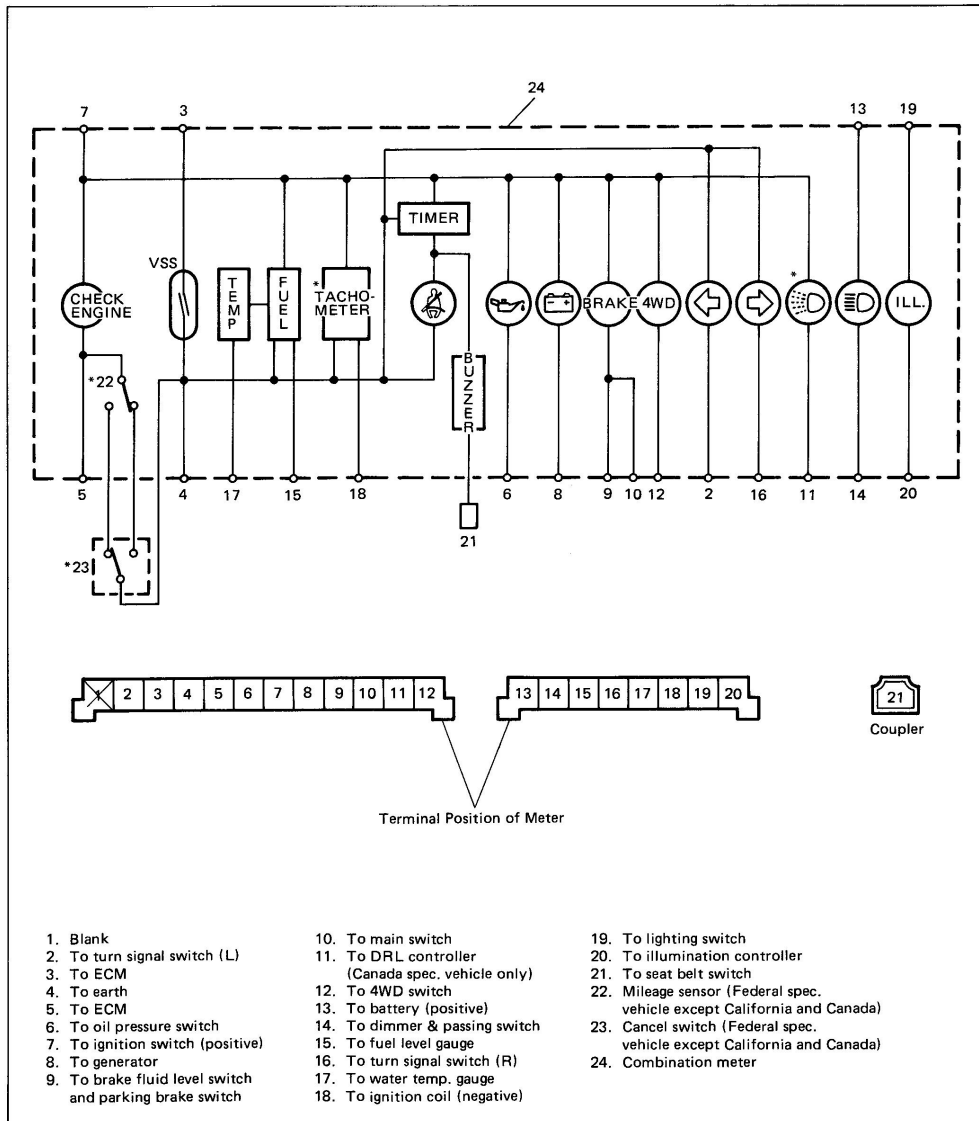

Fig. 21-1 Combination Meter Wiring

21-2

21-17. DAYTIME RUNNING LIGHT (D.R.L.) SYSTEM (If equipped)

GENERAL DESCRIPTION

If equipped with this system, the headlights light, though dimmer than the low beam, when the following three conditions are all met. Also, D.R.L. indicator light in the combination meter comes ON at the same time.

Conditions for D.R.L. system operation

1. The engine is running.
2. The parking brake is not applied.
3. The lighting switch is at either "OFF" or "clearance light" position.

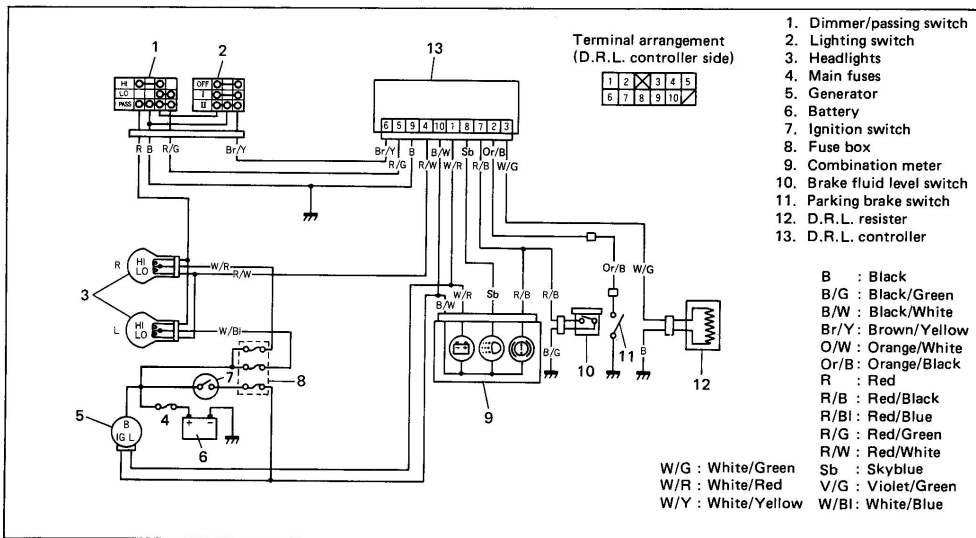

Fig. 21-2 D.R.L. System Circuit

NOTE:

- D.R.L. controller is located at the backside of glove box.
- D.R.L. resistor is located inside front fender LH panel at fender apron panel.

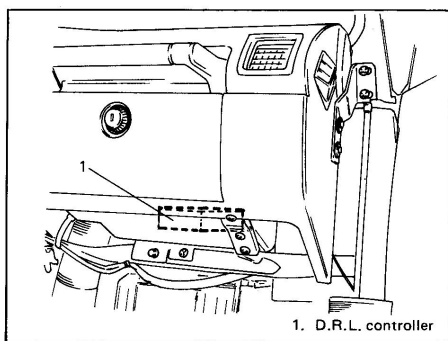

Fig. 21-3

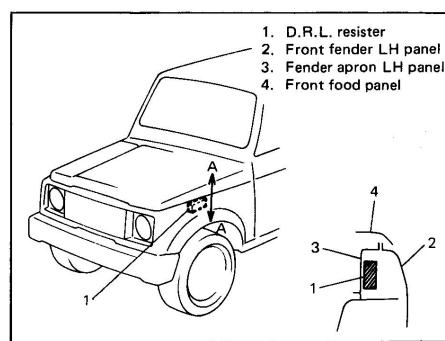
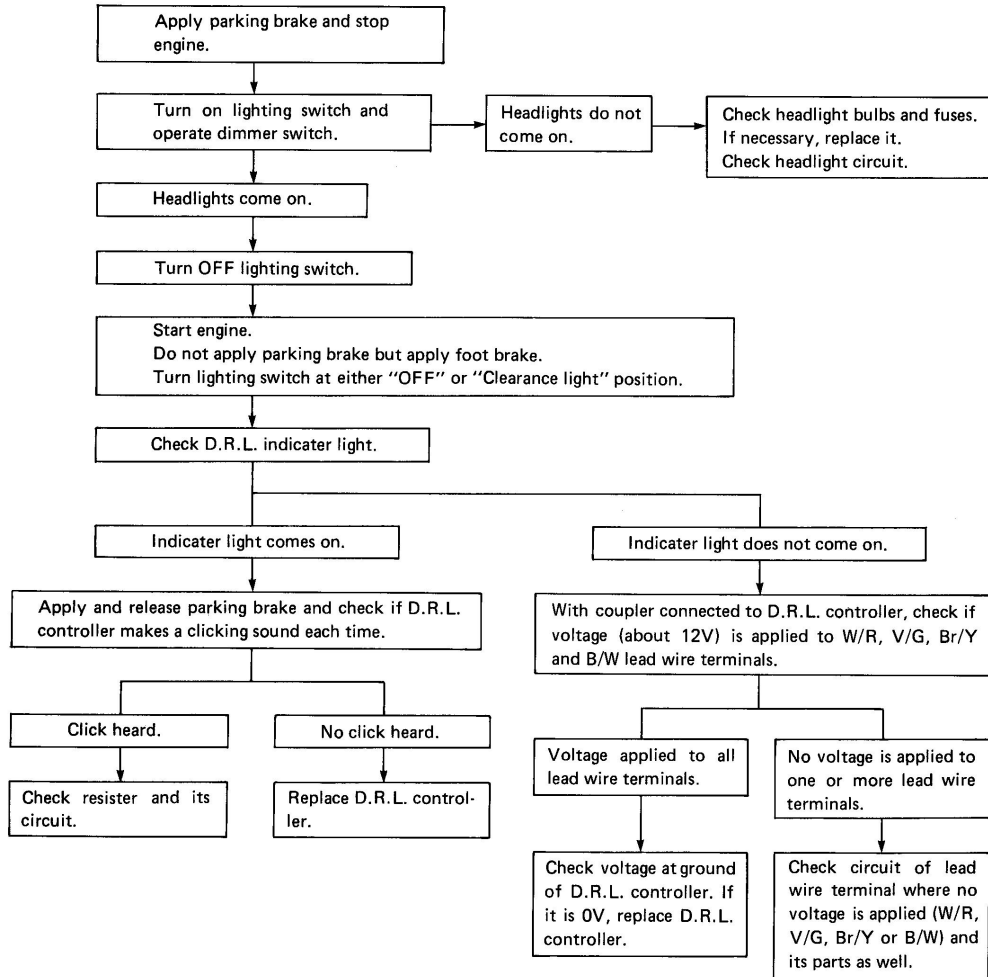

Fig. 21-4

TROUBLE DIAGNOSIS

When a trouble has occurred in this system, check it by using the following flow chart 1) or trouble-diagnosis chart 2) depending on symptom.

1) D.R.L. system does not operate.



2) D.R.L. system fails to stop.

Trouble	Possible cause	Correction
D.R.L. system remains operating even after engine stop.	D.R.L. controller faulty. W/R circuit faulty.	Replace controller. Repair.
D.R.L. system remains operating even after parking brake applied.	Parking brake switch faulty. V/G circuit faulty.	Replace switch. Repair.
D.R.L system remains operating even after lighting switch turned ON.	Lighting switch faulty. Br/Y circuit or its ground faulty.	Repair or replace switch. Repair.

SECTION 22

SERVICE DATA

CONTENTS

22-1. SPECIFICATIONS 22-1

22-2. SERVICE DATA 22-4

22-1. SPECIFICATIONS

Item	Models	Convertible/Hard Top
ENGINE		
Type	Four-stroke cycle, water cooled, OHC	
Number of cylinders	4	
Lubrication system	Wet sump	
Bore	74.0 mm (2.91 in.)	
Stroke	75.5 mm (2.97 in.)	
Piston displacement	1,298 cm ³ (1,298 cc, 79.2 cu. in.)	
Compression ratio	9.5 : 1	
Electronic Fuel Injection system	Single-point throttle body fuel injection system	
Air cleaner	Polyester fiber element (Dry type)	
ELECTRICAL		
Ignition timing	8° B.T.D.C. at 800 r/min (rpm)	
Standard spark plug	NGK BPR5ES or NIPPON DENSO W20EPR-U	
Starter	Magnetic shift type	
Generator	Alternator	
Battery	12V, 137 kC (38 Ah)/5HR	
Headlight	12V, 60/50W	
Turn signal light	12V, 32 cp	
Clearance light	12V, 4 cp	

Item	Models	Convertible/Hard Top
Tail/Brake light		12V, 3/32 cp
Side marker light		12V, 3.8W
License plate light		12V, 4 cp
Back-up light		12V 32 cp
Interior light		12V, 5W
Meter pilot light		12V, 1.4W
Main fuse		0.5 mm ² (fusible link)
Fuse box		10/10/15/15/15/20/15/15/10/15/15/20A
POWER TRANSMISSION		
Clutch type		Dry, single disc
Transmission type		5-forward all synchromesh, 1 reverse
Final reduction ratio (Differential)		3.727
Transmission gear ratios	low	3.652
	2nd	1.947
	3rd	1.423
	4th	1.000
	5th	0.864
	reverse	3.466
Transfer gear ratios	low range	2.268
	high range	1.409
Overall reduction ratios:		
Low range	low	30.869
	2nd	16.457
	3rd	12.028
	4th	8.452
	5th	7.303
	reverse	29.297
High range	low	19.177
	2nd	10.224
	3rd	7.472
	4th	5.251
	5th	4.537
	reverse	18.201

Item	Models	Convertible/Hard Top
WHEEL AND SUSPENSION		
Tire size: front and rear		P205/70 R15
Tire pressure	front	140 kPa (1.40 kg/cm ² , 20 psi)
	rear	140 kPa (1.40 kg/cm ² , 20 psi)-unladen
		180 kPa (1.80 kg/cm ² , 26 psi)-laden
Suspension type	front	Leaf spring
	rear	Leaf spring
STEERING		
Turning radius		5.1 m (16.7 ft)
Steering gear box		Ball nut type
Toe-in		2 – 6 mm (0.08 – 0.24 in.)
Camber angle		1° 00'
Caster angle		3° 30'
King pin angle		9° 00'
BRAKE SYSTEM		
Type		4-wheel, hydraulic
Wheel brake	front	Disc brake (floating caliper type)
	rear	Drum brake (leading and trailing)
Parking brake		Mechanical actuated on rear wheels
CAPACITIES		
Cooling solution		4.8 ℓ (10.1/8.4 US/Imp pt)
Fuel tank		40ℓ (10.6/8.8 US/Imp gal)
Engine oil		3.5 ℓ (7.4/6.2 US/Imp pt)
Transmission oil		1.3 ℓ (2.7/2.3 US/Imp pt)
Differential gear box oil	front	2.0 ℓ (4.2/3.5 US/Imp pt)
	rear	1.5 ℓ (3.2/2.6 US/Imp pt)
Transfer gear box oil		0.8 ℓ (1.7/1.4 US/Imp pt)

**22-2. SERVICE DATA
ENGINE**

Item		Standard	Service Limit	
Compression pressure		14.0 kg/cm ² (199.0 psi)	12.0 kg/cm ² (170.0 psi)	
	Difference between cylinders	_____	1.0 kg/cm ² (14.2 psi)	
Valve lash (clearance)	Cold (When coolant temperature is 15 ~ 25°C or 59 ~ 77°F)	Inlet	0.13 ~ 0.18 mm (0.0051 ~ 0.0071 in.)	
		Exhaust	0.15 ~ 0.21 mm (0.0059 ~ 0.0083 in.)	
	Hot (When coolant temperature is 60 ~ 68°C or 140 ~ 154°F)	Inlet	0.23 ~ 0.27 mm (0.009 ~ 0.011 in.)	
		Exhaust	0.26 ~ 0.30 mm (0.0102 ~ 0.0118 in.)	
Cylinder head	Flatness of gasketed surface		_____ 0.05 mm (0.002 in.)	
	Flatness of manifold seat	Inlet	_____ 0.1 mm (0.004 in.)	
		Exhaust	_____ 0.1 mm (0.004 in.)	
	Valve seat	Seating width	Inlet	1.3 ~ 1.5 mm (0.0512 ~ 0.0590 in.)
			Exhaust	1.3 ~ 1.5 mm (0.0512 ~ 0.0590 in.)
	Seating angle		45°	
Valve guide hole diameter (In & Ex) (over size)		12.030 ~ 12.048 mm (0.4736 ~ 0.4743 in.)		
Valve, valve spring & cam shaft	Camshaft/Journal clearance		0.050 ~ 0.091 mm (0.0020 ~ 0.0036 in.) 0.15 mm (0.0059 in.)	
	Camshaft thrust clearance		_____ 0.75 mm (0.0295 in.)	
	Cam height (Base circle + lift)	Inlet	38.136 mm (1.5014 in.)	38.036 mm (1.4975 in.)
		Exhaust	38.136 mm (1.5014 in.)	38.036 mm (1.4975 in.)
	Camshaft runout		_____ 0.10 mm (0.0039 in.)	
	Valve stem diameter	Inlet	6.965 ~ 6.980 mm (0.2742 ~ 0.2748 in.)	_____
		Exhaust	6.950 ~ 6.965 mm (0.2737 ~ 0.2742 in.)	_____
	Valve guide I.D.	Inlet	7.000 ~ 7.015 mm (0.2756 ~ 0.2761 in.)	_____
		Exhaust	7.000 ~ 7.015 mm (0.2756 ~ 0.2761 in.)	_____
	Valve guide-to-valve stem clearance	Inlet	0.020 ~ 0.050 mm (0.0008 ~ 0.0019 in.)	0.07 mm (0.0027 in.)
		Exhaust	0.035 ~ 0.065 mm (0.0014 ~ 0.0025 in.)	0.09 mm (0.0035 in.)
	Thickness of valve head periphery	Inlet	1.0 mm (0.039 in.)	0.6 mm (0.0236 in.)
		Exhaust	1.0 mm (0.039 in.)	0.7 mm (0.0275 in.)
	Contact width of valve and valve seat	Inlet	1.3 ~ 1.5 mm (0.0512 ~ 0.0590 in.)	_____
Exhaust		1.3 ~ 1.5 mm (0.0512 ~ 0.0590 in.)	_____	
Valve spring free length	Inlet	49.3 mm (1.9409 in.)	48.1 mm (1.8937 in.)	
	Exhaust	49.3 mm (1.9409 in.)	48.1 mm (1.8937 in.)	
Valve spring preload	Inlet	24.8 ~ 29.2 kg (54.7 ~ 64.3 lb) for fitting length 41.5 mm (1.63 in.)	22.8 kg (50.2 lb) for fitting length 41.5 mm (1.63 in.)	
	Exhaust	24.8 ~ 29.2 kg (54.7 ~ 64.3 lb) for fitting length 41.5 mm (1.63 in.)	22.8 kg (50.2 lb) for fitting length 41.5 mm (1.63 in.)	

Item		Standard	Service Limit	
Valve, valve spring & cam shaft	Valve stem end deflection	Inlet	0.14 mm (0.005 in.)	
		Exhaust	0.18 mm (0.007 in.)	
	Stock allowance of valve stem end face		0.5 mm (0.019 in.)	
	Valve head radial runout		0.08 mm (0.003 in.)	
	Valve spring squareness		2.0 mm (0.079 in.)	
	Valve guide protrusion (In. & Ex.)		14 mm (0.55 in.)	
Rocker arm shaft and rocker arm	Rocker shaft O.D.		15.973 ~ 15.988 mm (0.628 ~ 0.629 in.)	
	Rocker arm I.D.		16.000 ~ 16.018 mm (0.629 ~ 0.630 in.)	
	Shaft-to-arm clearance	Inlet	0.012 ~ 0.045 mm (0.0005 ~ 0.0017 in.)	0.09 mm (0.0035 in.)
		Exhaust	0.012 ~ 0.045 mm (0.0005 ~ 0.0017 in.)	0.09 mm (0.0035 in.)
	Rocker shaft runout		0.12 mm (0.004 in.)	
Cylinder	Flatness of gasketed surface		0.03 mm (0.0012 in.)	
	Cylinder bore (S.T.D.)		74.00 ~ 74.02 mm (2.9134 ~ 2.9142 in.)	
	Cylinder bore out-of-round and taper		0.10 mm (0.0039 in.)	
	Cylinder-to-piston clearance		0.02 ~ 0.04 mm (0.0008 ~ 0.0015 in.)	
Piston	Piston diameter	Standard	73.970 ~ 73.990 mm (2.9122 ~ 2.9129 in.)	
		Oversize: 0.25 mm (0.0098 in.)	74.220 ~ 74.230 mm (2.9220 ~ 2.9224 in.)	
		Over size: 0.50 mm (0.0196 in.)	74.470 ~ 74.480 mm (2.9319 ~ 2.9322 in.)	
	Piston ring groove width	Top ring	1.22 ~ 1.24 mm (0.0480 ~ 0.0488 in.)	
		2nd ring	1.51 ~ 1.53 mm (0.0594 ~ 0.0602 in.)	
		Oil ring	2.81 ~ 2.83 mm (0.1106 ~ 0.1114 in.)	
Piston pin diameter		16.995 ~ 17.000 mm (0.6691 ~ 0.6693 in.)		
Piston ring	Piston ring thickness	Top ring	1.17 ~ 1.19 mm (0.0461 ~ 0.0468 in.)	
		2nd ring	1.47 ~ 1.49 mm (0.0578 ~ 0.0586 in.)	
		Oil ring	0.45 mm (0.0177 in.)	
	Ring clearance in groove	Top ring	0.03 ~ 0.07 mm (0.0012 ~ 0.0027 in.)	0.12 mm (0.0047 in.)
		2nd ring	0.02 ~ 0.06 mm (0.0008 ~ 0.0023 in.)	0.10 mm (0.0039 in.)
	Piston ring end gap	Top ring	0.20 ~ 0.33 mm (0.0079 ~ 0.0129 in.)	0.7 mm (0.0275 in.)
		2nd ring	0.20 ~ 0.35 mm (0.0079 ~ 0.0137 in.)	0.7 mm (0.0275 in.)
Oil ring		0.20 ~ 0.70 mm (0.0079 ~ 0.0275 in.)	1.8 mm (0.0708 in.)	
Crank shaft	Crankshaft runout (middle)		0.06 mm (0.0023 in.)	
	Crank pin diameter		41.982 ~ 42.000 mm (1.6529 ~ 1.6535 in.)	
	Crank pin clearance in con. rod		0.030 ~ 0.050 mm (0.0012 ~ 0.0019 in.)	
	Connecting rod small end bore		16.968 ~ 16.979 mm (0.6680 ~ 0.6684 in.)	
	Crank journal diameter		44.982 ~ 45.000 mm (1.7710 ~ 1.7716 in.)	
	Bearing-to-journal clearance		0.020 ~ 0.040 mm (0.0008 ~ 0.0016 in.)	
	Crank pin out-of-round and taper		0.01 mm (0.0004 in.)	

Item		Standard		Service Limit	
Crankshaft	Crank journal out-of-round and taper		_____		0.01 mm (0.0004 in.)
	Flywheel runout		_____		0.2 mm (0.0078 in.)
	Crankshaft thrust play		0.11 – 0.31 mm (0.0044 ~ 0.0122 in.)	0.38 mm (0.0149 in.)	
	Connecting rod big end side clearance		0.10 ~ 0.20 mm (0.0039 ~ 0.0078 in.)	0.35 mm (0.0137 in.)	
	Connecting rod	Twist	_____		0.10 mm (0.0039 in.)
Bow		_____		0.05 mm (0.0020 in.)	

CLUTCH & TRANSMISSION

Item		Standard		Service Limit	
Clutch	Facing wear (Rivet head depth)		1.2 mm (0.05 in.)	0.5 mm (0.02 in.)	
	Facing-input shaft serration backlash		_____		0.8 mm (0.03 in.)
Transmission	Clearance between gears and rings	Low & high	1.0 ~ 1.4 mm (0.039 ~ 0.055 in.)	0.5 mm (0.019 in.)	
		5th speed	1.2 ~ 1.6 mm (0.047 ~ 0.063 in.)	0.5 mm (0.019 in.)	
	Key slot width of synchronizer ring		10.1 mm (0.397 in.)	10.4 mm (0.409 in.)	
	Gear shift fork shaft spring free length		25.5 mm (1.004 in.)	21.0 mm (0.826 in.)	
	Gear backlash		0.06 ~ 0.15 mm (0.0024 ~ 0.0059 in.)	0.3 mm (0.0118 in.)	

LUBRICATION

Item		Standard		Service Limit	
Lubrication	Radial clearance between outer rotor and case		_____		0.310 mm (0.0122 in.)
	Oil pump side clearance (flatness)		_____		0.15 mm (0.0059 in.)
	Oil relief valve spring	Free length	45 mm (1.77 in.)	_____	
	Set pressure of oil pressure switch		0.2 ~ 0.4 kg/cm ² (2.84 ~ 5.68 psi)	_____	
	Engine oil pressure		3.0 ~ 4.2 kg/cm ² (42.7 ~ 59.7 psi) at 3,000 r/min (rpm)		_____

COOLING SYSTEM

Item		Standard	Service Limit
Cooling system	Fan belt tension as deflection under 10 kg (22 lb) push applied to middle point between pulleys	6 ~ 9 mm (0.23 ~ 0.35 in.)	_____
	Thermostat start-to-open temperature	*82°C (179°F) or 88°C (190°F)	_____
	Thermostat full-open temperature	*95°C (203°F) or 100°C (212°F)	_____
	Valve lift	8 mm (0.31 in.)	_____

* There are two types of thermostat depending on specifications.

DIFFERENTIAL

Item		Standard	Service Limit
Differential	Bevel gear backlash	0.10 ~ 0.15 mm (0.004 ~ 0.006 in.)	_____
	Side gear thrust play	0.12 ~ 0.37 mm (0.005 ~ 0.014 in.)	_____
	Pinion bearing preload	1.8 ~ 3.4 kg (4.0 ~ 7.5 lbs.)	_____

SUSPENSION

Item		Standard	Service Limit
Suspension	Front wheel bearing starting preload	1.0 ~ 3.0 kg (2.2 ~ 6.6 lbs.)	_____
	Rear wheel bearing thrust play	_____	0.8 mm (0.03 in.)
	Axial play in barfield joint	0 mm (No play)	1.5 mm (0.06 in.)
	Knackle arm starting torque (without oil seal)	1.0 ~ 1.8 kg (2.20 ~ 3.96 lbs.)	_____

FUEL SYSTEM

Item	Standard	Limit
Engine idle speed	800 ± 50 r/min (rpm)	_____
Engine idle speed when turning A/C "ON"	1,000 ± 50 r/min (rpm)	_____

STEERING SYSTEM

Item	Standard	Service Limit
Gear ratio	15.6 ~ 18.1	_____
Steering angle, inside	29°	_____
Steering angle, outside	26°	_____
Steering wheel play	10 ~ 30 mm (0.4 ~ 1.2 in.)	_____

BRAKE

Item	Standard	Service Limit
Front brake disc thickness	10 mm (0.394 in.)	8.5 mm (0.334 in.)
Front brake disc deflection	_____	0.15 mm (0.006 in.)
Front brake pad thickness (lining + pad rim)	15.0 mm (0.590 in.)	6.0 mm (0.236 in.)
Rear brake lining thickness (lining + shoe rim)	7.0 mm (0.28 in.)	3.0 mm (0.12 in.)
Rear brake drum inside diameter	220 mm (8.66 in.)	222 mm (8.74 in.)
Pedal-to-wall clearance: When pedal is depressed at 30 kg (66 lb)	75 mm (2.95 in.) minimum	_____

ELECTRICAL

Item	Standard	Service Limit	
Ignition system	Ignition order	1 - 3 - 4 - 2	_____
	High tension cord resistance	10 ~ 22 kΩ/m 3.0 ~ 6.7 kΩ/ft	_____
	Ignition coil; Primary coil resistance (20°C, 68°F)	0.9 ~ 1.1 ohms	_____
	Ignition coil; Secondary coil resistance (20°C, 68°F)	10.2 ~ 13.8 kilohms	_____
	Spark plug gap	0.7 ~ 0.8 mm (0.027 ~ 0.031 in.)	_____

	Item	Standard	Service Limit
Starter motor	Voltage	12 Volts	_____
	Output	0.9 kw	_____
	Rating	30 seconds	_____
	Brush length	17 mm (0.67 in.)	11.5 mm (0.45 in.)
	Number of pinion teeth	8	_____
	Commutator diameter	32 mm (1.26 in.)	31 mm (1.22 in.)
	Mica depth	0.4 ~ 0.6 mm (0.015 ~ 0.023 in.)	0.2 mm (0.008 in.)
	Commutator out of round	0.05 mm (0.0019 in.) or less	0.4 mm (0.015 in.)
	Brush spring tension	1.6 kg (3.53 lb)	1.0 kg (2.20 lb)
Charging system	Nominal operating voltage	12 Volts	_____
	Maximum alternator output	50A	_____
	Maximum permissible alternator speed	15,000 r/min (rpm)	_____
	Working temperature range	-30 ~ 90°C (-22 ~ 194°F)	_____
	Rotor; Ring-to-ring circuit resistance	2.8 ~ 3.0 ohms	_____
	Brush length	11.0 mm (0.43 in.)	5.0 mm (0.20 in.)
	Standard output voltage and current	14.2 ~ 14.8 Volts, 10A maximum	_____
	Regulated voltage	14.2 ~ 14.8 Volts	_____

GROUP 1

Prepared by

SUZUKI MOTOR CORPORATION

Automobile Department
Overseas Service Division

1st Ed. May, 1989
2nd Ed. May, 1991

Printed in Japan

GROUP 2

SUZUKI

samurai

SUPPLEMENTARY SERVICE MANUAL
FOR 1991/1992/1993 2WD MODEL

FOREWORD

This supplementary service manual (GROUP 2) has been prepared for the 1991, 1992 and 1993 SAMURAI 2WD MODEL.

It describes different service information of 2WD MODEL as compared with 4WD MODEL.

Therefore, whenever servicing 2WD MODEL, consult GROUP 2 first. And for any section, item or description not found in GROUP 2, refer to GROUP 1.

All information, illustrations and specifications contained in this literature are based on the latest product information available at the time of publication approval. And used as the main subject of description is the vehicle of standard specifications among others. Therefore, note that illustrations may differ from the vehicle being actually serviced. The right is reserved to make changes at any time without notice.

TABLE OF CONTENTS

	SECTION
GENERAL, SPECIAL TOOLS AND SERVICE MATERIALS	0
PERIODIC MAINTENANCE SERVICE	1
EMISSION CONTROL SYSTEM	5
TRANSFER GEAR BOX	14
PROPELLER SHAFTS	15
DIFFERENTIAL	16
SUSPENSION	17
STEERING SYSTEM	18
SERVICE DATA	22

GROUP 2

SUZUKI MOTOR CORPORATION

*AUTOMOBILE DEPARTMENT
OVERSEAS SERVICE DIVISION*

© COPYRIGHT SUZUKI MOTOR CORPORATION 1993

SECTION 0

GENERAL, SPECIAL TOOLS AND SERVICE MATERIALS

0

NOTE:

For the items not found in this section, refer to the same section in GROUP 1.

CONTENTS

0-1. IDENTIFICATION NUMBER	0-1
0-2. STANDARD SHOP PRACTICES	0-2

0-1. IDENTIFICATION NUMBER

VEHICLE IDENTIFICATION NUMBER

The vehicle identification number is on the instrument panel left side.
Refer to below figure for detailed VIN cord information and its location.

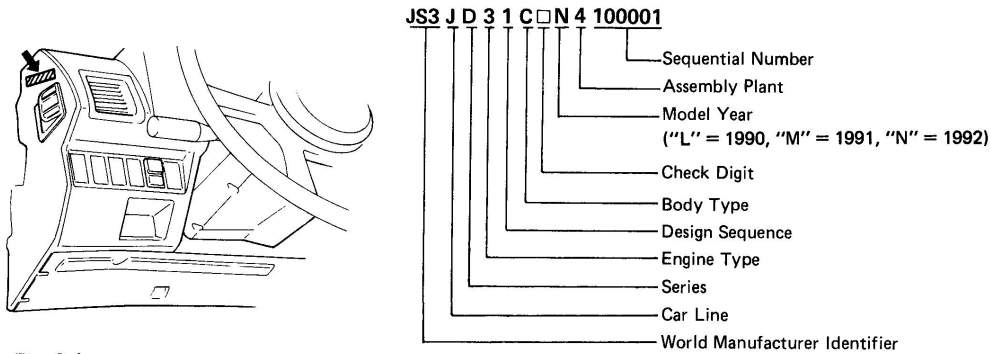

Fig. 0-1

0-1

0-2. STANDARD SHOP PRACTICES

When using the garage jack, be sure to place it against the center of the axle housing to raise the front vehicle end and against the differential portion of the axle housing to raise the rear end.

NOTE:

Don't get on the vehicle, get under it or service it in this state.

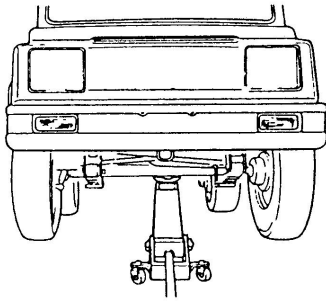

Fig. 0-2 Front Side

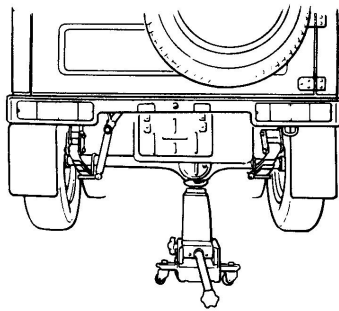

Fig. 0-3 Rear Side

SECTION 1

PERIODIC MAINTENANCE SERVICE

1

NOTE:

For the items not found in this section, refer to the same section in GROUP 1.

CHASSIS AND BODY

- Refer to page 17-18 in SECTION 17 in GROUP 2 for replacement of the steering knuckle oil seal.
- For servicing procedures such as inspection of the front wheel bearing, disassembly and assembly of the front wheel hub, refer to SECTION 17 in GROUP 2.

SECTION 5

EMISSION CONTROL SYSTEM

NOTE:

For the items not found in this section, refer to the same section in GROUP 1.

5

CONTENTS

5-1. GENERAL DESCRIPTION	5-2
POSITIVE CRANKCASE VENTILATION (PCV) SYSTEM	5-2
5-2. ON VEHICLE SERVICE	5-3
GENERAL	5-3
PCV SYSTEM	5-3

5-1

5-1. GENERAL DESCRIPTION

POSITIVE CRANKCASE VENTILATION (PCV) SYSTEM

As to this system, the one used for the '91 – '93 Model is basically the same as that for the '90 Model. Only, the layouts of the PCV hose and breather hose are different and the ones for the '91 – '93 Model are shown at the right.

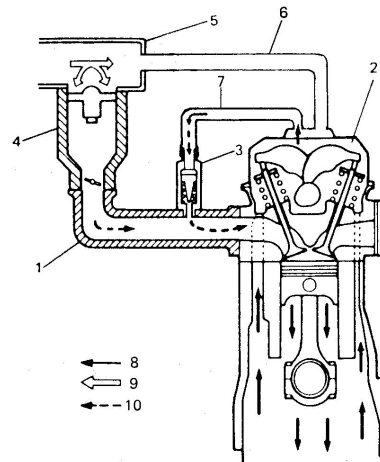

- | | |
|------------------------|--|
| 1. Intake manifold | 7. PCV hose |
| 2. Cylinder head cover | 8. Blow-by gas |
| 3. PCV valve | 9. Fresh air |
| 4. Throttle body | 10. Blow-by gas and
fresh air mixture |
| 5. Air intake case | |
| 6. Breather hose | |

Fig. 5-1 PCV System Operation

5-2. ON VEHICLE SERVICE

GENERAL

When the emission control hoses are disconnected and the system's component is removed for service, reinstall the component properly, and route and connect hoses correctly after service. Refer to Vehicle Emission Control Information Label for proper routing of hoses.

PCV SYSTEM

NOTE:

Be sure to check that there is no obstruction in PCV valve or its hoses before adjusting engine idle speed, for obstructed PCV valve or hose hampers its accurate adjustment.

PCV Hose & Breather Hose

Check hoses for connection, leakage, clog, and deterioration. Replace as necessary.

PCV Valve

1. Disconnect PCV hose from PCV valve.
2. Run engine at idle.
3. Place your finger over end of PCV valve to check for vacuum. If there is no vacuum, check for clogged valve. Replace as necessary.

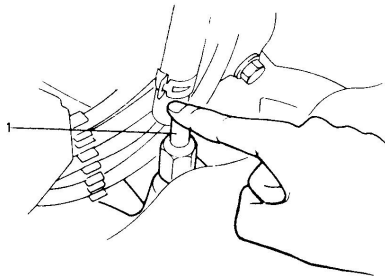

1. PCV valve

Fig. 5-2 Checking Vacuum

4. After checking vacuum, stop engine and check PCV valve for sticking.

With engine stopped, connect a new hose to PCV valve.

Blow air into new hose and check that air flows with difficulty from cylinder head side to intake manifold side. If air flows without difficulty, valve is stuck in "Open" position. Replace PCV valve.

WARNING:

Do not suck air through PCV valve. Petroleum substances inside the valve and fuel vapor inside the intake manifold are harmful.

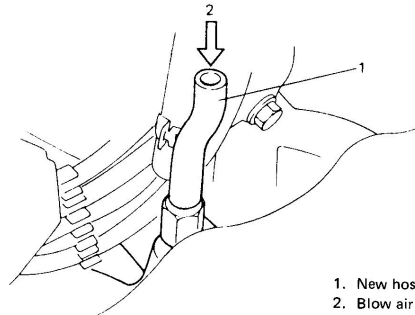

1. New hose
2. Blow air

Fig. 5-3 Checking PCV Valve for Sticking

5. Connect PCV hose and clamp securely.

SECTION 14

TRANSFER GEAR BOX

CONTENTS

14- 1.	GENERAL DESCRIPTION	14- 2
14- 2.	POWER FLOW OF TRANSFER	14- 3
14- 3.	GEAR RATIO DATA	14- 3
14- 4.	TRANSFER SERVICES NOT REQUIRING TRANSFER REMOVAL	14- 4
14- 5.	REMOVAL	14- 5
14- 6.	DISASSEMBLY	14- 6
14- 7.	INSPECTION OF COMPONENTS	14- 8
14- 8.	REASSEMBLY	14- 9
14- 9.	MAINTENANCE SERVICES	14-14
14-10.	TIGHTENING TORQUE	14-15
14-11.	SPECIAL TOOLS	14-15
14-12.	REQUIRED SERVICE MATERIALS	14-15

14-1. GENERAL DESCRIPTION

Shown in figure below are component parts included in the transfer gear box. Main parts are 3 shafts and 3 gears. Among those 3 gears, the one on input and output shafts is incorporated with shafts as one unit.

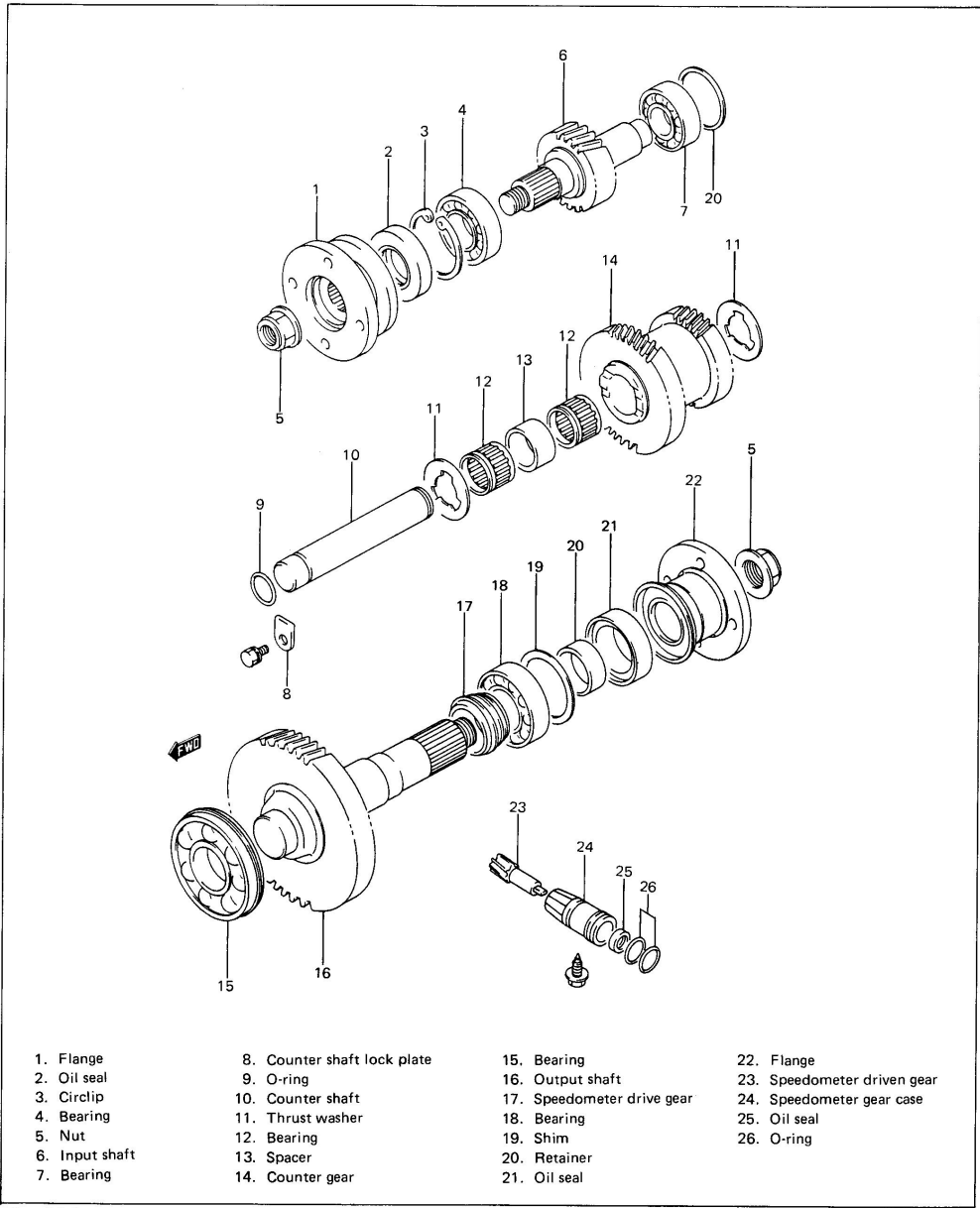

Fig. 14-1

14-2. POWER FLOW OF TRANSFER

The drive force is transmitted from the transmission through the input shaft of the transfer and the gear of the counter shaft to the output shaft. Then from the output shaft, it is transmitted through the propeller shaft to the differential.

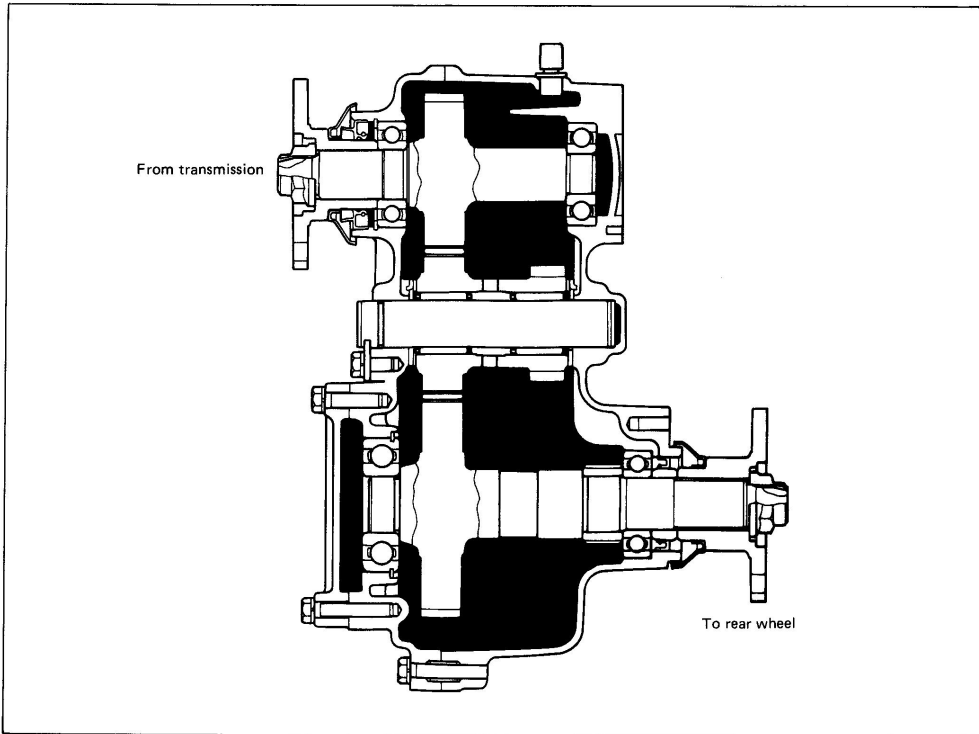

Fig. 14-2

14-3. GEAR RATIO DATA

	Gear ratio	Reduction ratio
Rear-wheel drive	$41/44 \cdot 62/41$	1.409

14-4. TRANSFER SERVICES NOT REQUIRING TRANSFER REMOVAL

Following parts or components do not require transfer removal to receive services (replacement, inspection):

Part or Component	Nature of Service
1. Universal-joint yoke flanges	Replacement or inspection
2. Transfer output shaft front case	Replacement
3. Transfer input shaft oil seal	Replacement
4. Speedometer driven gear	Replacement or inspection

14-5. REMOVAL

- 1) Lift up vehicle and remove securing bolts from each universal-joint flange connection to sever 2 propeller shafts from transfer gear box.

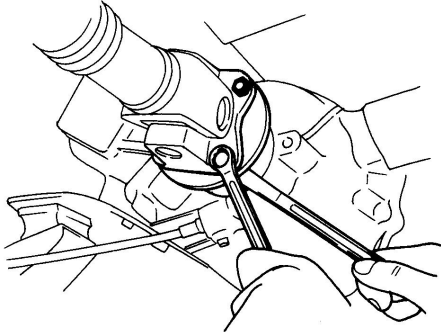

Fig. 14-3

- 2) Drain out oil from gear box by loosening its drain plug.

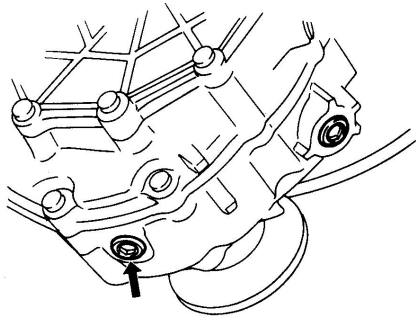

Fig. 14-4

- 3) Disconnect speedometer drive cable from transfer gear box.

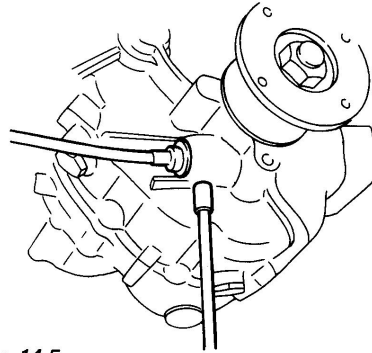

Fig. 14-5

- 4) Remove mounting nuts securing gear box to chassis, and take down gear box.

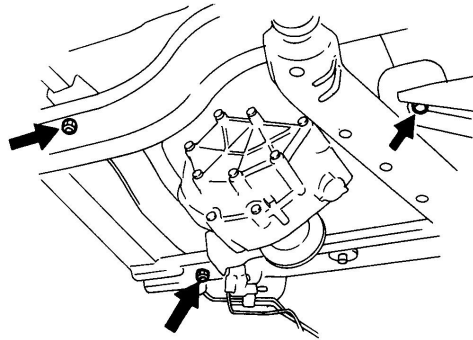

Fig. 14-6

14-6. DISASSEMBLY

Universal-Joint Yoke Flanges

There are 2 flanges to be removed: one from input shaft and other from output shaft. Lock flange so that it will not turn, and loosen and remove nut holding flange to the shaft. Draw off flange.

(A) Special tool (09922-66020)

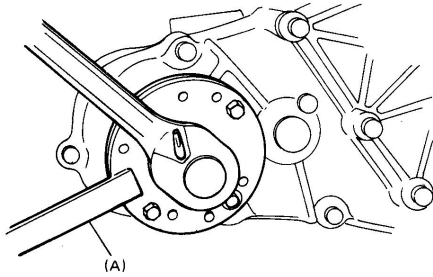

Fig. 14-7

Speedometer Driven Gear

Loosen speedometer driven gear case bolt and remove speedometer driven gear case with gear.

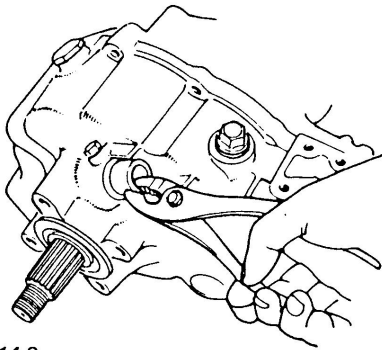

Fig. 14-8

Transfer Center Case

Remove bolts fastening center case, output shaft front case and rear case together.

NOTE:

Do not loosen lock plate bolt at this point.

14-6

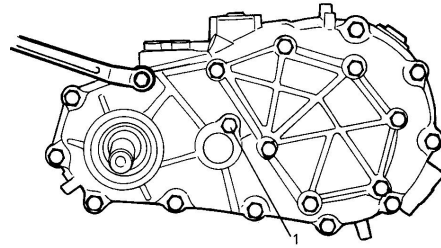

1. Counter shaft lock plate bolt

Fig. 14-9

By tapping rear case and output shaft with a plastic hammer, separate center and rear case.

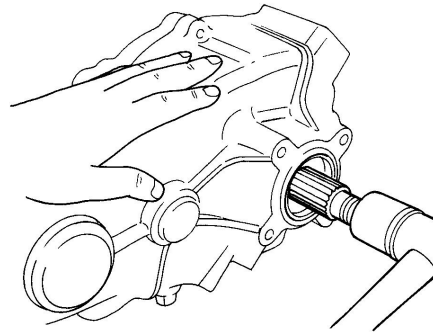

Fig. 14-10

Given below are procedures for disassembling component parts of center case as separated from rear case.

- 1) Pull out counter gear, bearings and spacer.
- 2) Hammer output rear shaft with a plastic hammer to drive it out of center case.

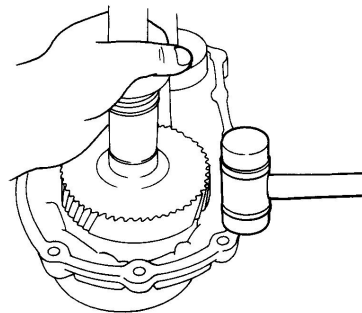

Fig. 14-11

- 3) Remove counter shaft from center case by loosening counter shaft lock plate bolt.

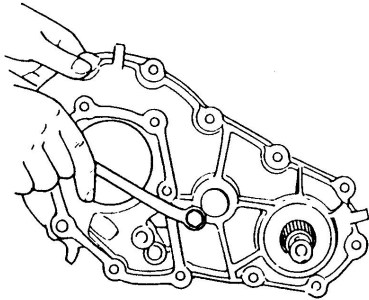

Fig. 14-12

- 4) Remove input shaft from center case by hammering thick part of case or input shaft center with a plastic hammer.

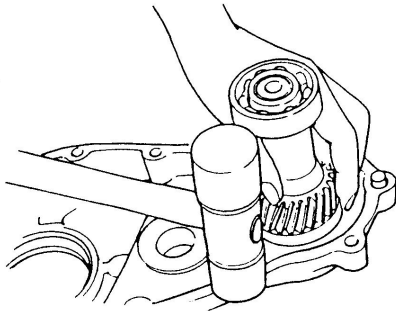

Fig. 14-13

- 5) Remove output shaft rear bearing and retainer together by using bearing puller.

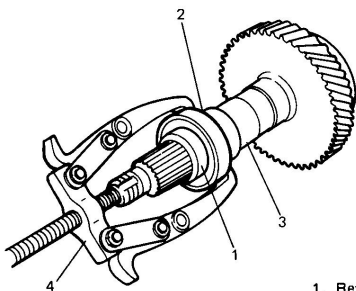
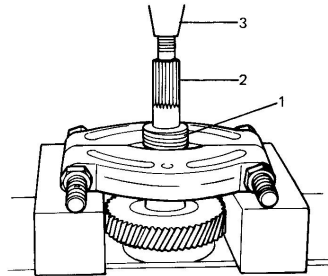

Fig. 14-14

1. Retainer
2. Bearing
3. Output shaft
4. Bearing puller

- 6) Remove speedometer drive gear by using bearing puller and press.

CAUTION:
When doing this work, be careful not to damage speedometer drive gear.



1. Speedometer drive gear
2. Output shaft
3. Press

Fig. 14-15

- 7) Remove output shaft front bearing by using bearing puller and puller attachment (special tool).

Puller attachment (B) 09926-58010

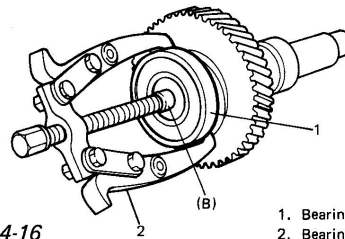

Fig. 14-16

1. Bearing
2. Bearing puller

- 8) When input shaft is removed or center case and rear case are separated, input shaft bearings may come off. In such a case, bearings can be removed from shaft by using bearing puller.

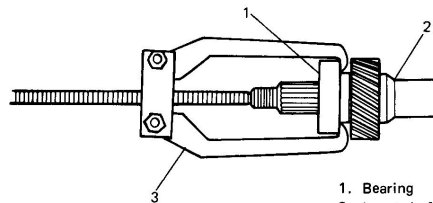

Fig. 14-17

1. Bearing
2. Input shaft
3. Bearing puller

9) When input shaft is removed, front bearing may be left in case. In this case, after removing oil seal and circlip, bearing can be taken out of case by using bearing installer (special tool). Bearing installer (C) : (09913-75810)

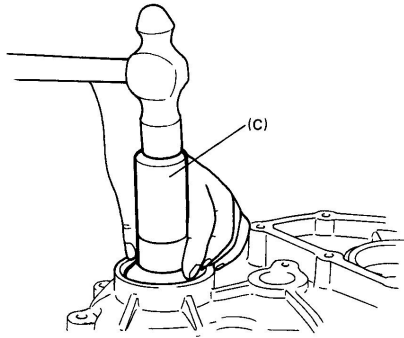
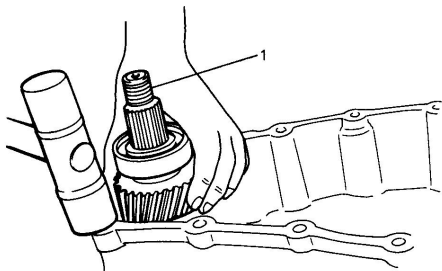

Fig. 14-18

Transfer Rear Case

When center case and rear case are separated, input shaft may be left in rear case. In this case, remove input shaft from rear case by hammering thick part of case with a plastic hammer.



1. Input shaft

Fig. 14-19

14-7. INSPECTION OF COMPONENTS

Gear Teeth

Inspect gear teeth, for wear, cracking, chipping and other malcondition. Replace gear as necessary.

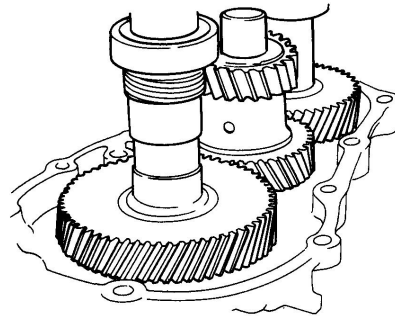

Fig. 14-20

Bearings

Check each bearing by spinning its outer race by hand to "feel" smoothness of rotation. Replace bearing if noted to exhibit sticking, resistance or abnormal noise when spun or rotated by hand.

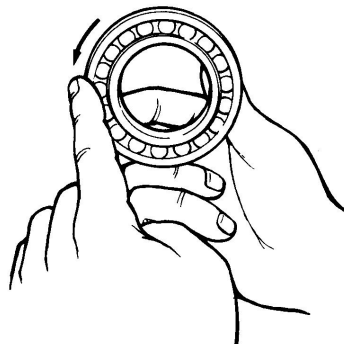

Fig. 14-21

14-8. REASSEMBLY

NOTE:

- All parts to be used in reassembly must be perfectly clean.
- Oil or grease sliding and rubbing surfaces of transfer components just before using them in reassembly with gear oil and SUZUKI SUPER GREASE A (99000-25010).
- Oil seals, "O" rings, gaskets and similar sealing members must be in perfect condition. For these members, use replacement parts in stock.
- Tightening torque is specified for important fasteners – mainly bolts – of transfer and other components. Use torque wrenches and constantly refer to specified data given in P. 14-15.

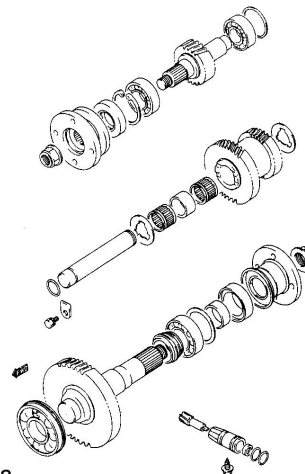

Fig. 14-23

Input Shaft

Press-fit bearings onto both sides of input shaft by using bearing installer (special tool).

Bearing installer (A) : (09913-84510)

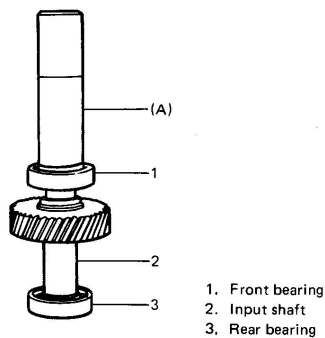

Fig. 14-22

Output Shaft

Install following parts onto shaft in such order and directions as prescribed in the figure.

- 1) Press-fit speedometer drive gear by using bearing installer (special tool).

Bearing installer (A) : (09913-84510)

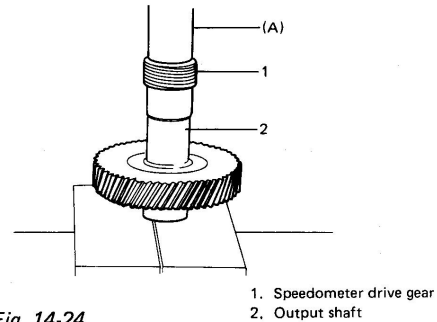

Fig. 14-24

- 2) Press-fit bearings and the retainer by using bearing installer (special tool).

Bearing installer (A) : (09913-84510)

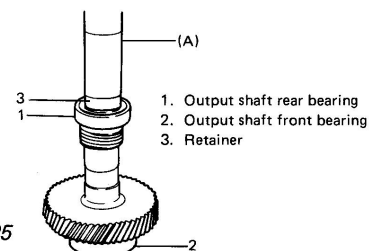

Fig. 14-25

- 3) Fit circlip securely into groove in out put shaft front bearing.

Shim Adjustment of Input and Output Shaft

Clearance in thrust direction of both input and output shafts is adjusted by putting shims between input shaft rear bearing and rear case for input shaft and between output shaft rear bearing and rear case for output shaft.

As thrust clearance is specified as follows, determine shim thickness to meet specification according to the following procedures.

Thrust clearance Specification	0.05 – 0.15 mm (0.002 – 0.006 in.)
--------------------------------	---------------------------------------

[Input shaft]

- 1) Take measurement "A" of rear case as shown in figure below by using depth gauge.
- 2) Take measurement "B" of center case with bearing circlip installed.
- 3) Take measurement "C" (between bearing inner races) of input shaft with bearings installed, by using micrometer.

NOTE:

- Before measuring, make sure that each bearing is free from abnormal noise or resistance by spinning its outer race.
- Each measurement in above steps 1) to 3) must be taken accurately in careful manner. If shim thickness is determined based on rough measurement, clearance of each shaft in thrust direction will not satisfy specification. And improper clearance may cause oil leakage, broken bearing and abnormal noise.
- Take the same measurement at 3 to 4 different positions and use their mean.

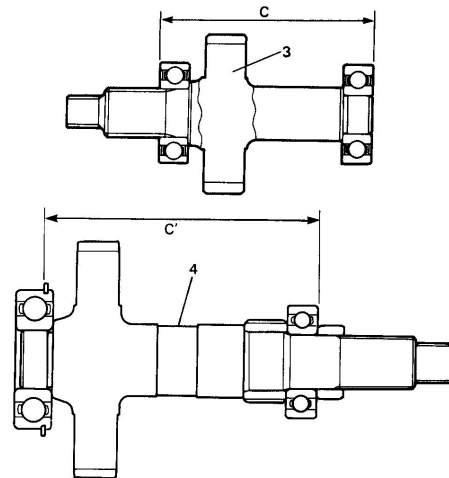
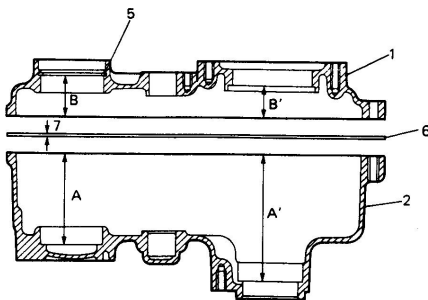

- | | | |
|----------------|--------------------|---|
| 1. Center case | 4. Output shaft | 7. Gasket thickness
(0.3 mm or 0.012 in) |
| 2. Rear case | 5. Bearing circlip | |
| 3. Input shaft | 6. Gasket | |

Fig. 14-26

- 4) Using measurements obtained in steps 1) to 3) and equation described below, calculate shim thickness which is necessary for proper thrust clearance.

$$\text{Thrust clearance} = ("A" + "B" + \text{Gasket thickness}) - "C"$$

As the above equation holds for thrust clearance and gasket thickness is specified as 0.3 mm and thrust clearance as 0.05 to 0.15 mm, shim thickness is calculated by the following equation.

$$\text{Shim thickness} = ("A" + "B" + 0.3) - ("C" + 0.05 \sim 0.15)$$

[Example]

Supposing A, B and C are as follows;

$$A = 81.35 \text{ mm (3.203 in.)}$$

$$B = 35.70 \text{ mm (1.405 in.)}$$

$$C = 117.05 \text{ mm (4.608 in.)}$$

$$\begin{aligned} \text{Shim thickness} &= (81.35 + 35.70 + 0.3) - \\ &\quad (117.05 + 0.05 \sim 0.15) \\ &= 117.35 - 117.10 \sim 117.20 \\ &= 0.25 \sim 0.15 \end{aligned}$$

In this case, use of 0.15 to 0.25 mm (0.006 to 0.009 in) thick shim(s) will ensure specified thrust clearance which is 0.05 to 0.15 mm (0.002 to 0.006 in). Therefore 2 pieces of 0.1 mm (0.004 in) thick shim should be selected in available shims below to satisfy thickness.

5) When shim thickness is determined, select proper shim(s) from among the following shims and use it (them) between input shaft rear bearing and rear case when matching center case and rear case.

Available shim size (thickness)	0.1, 0.3, 0.5 mm (0.004, 0.012, 0.020 in.)
---------------------------------	---

[Output shaft]

Just as with input shaft, take measurements of "A", "B" and "C" as indicated in Fig. 14-26, calculate shim thickness and install proper shim(s) between output shaft rear bearing and rear case when matching center case and rear case.

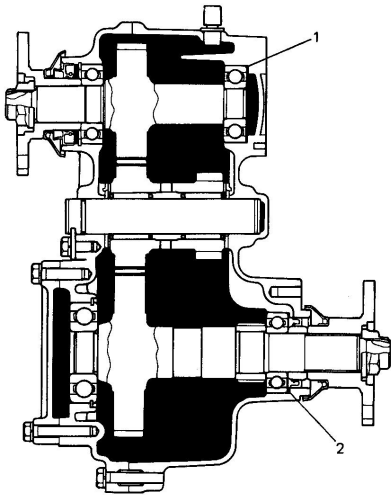

Fig. 14-27

- 1. Shim for input shaft
- 2. Shim for output shaft

Rear Case

1) Install oil seal in rear case and apply grease to oil seal lip.

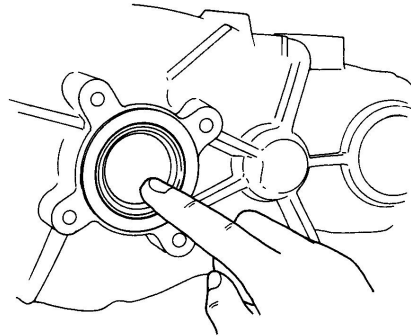

Fig. 14-28

2) Install counter shaft thrust washer to rear case, bringing its face without depressions against case and fit its bent portion securely into groove in case.

NOTE:

Apply ample amount of grease to both surfaces of washer so as to lubricate sliding surfaces and prevent washer from moving out of place or slipping off.

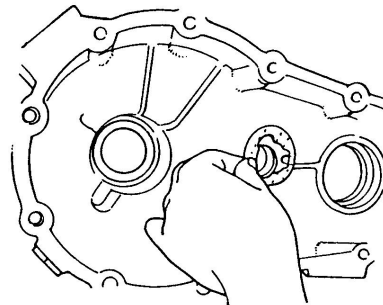

Fig. 14-29

Center Case

- 1) Install input shaft front bearing circlip and oil seal in center case.
Snap ring pliers (A) : (09900-06108)

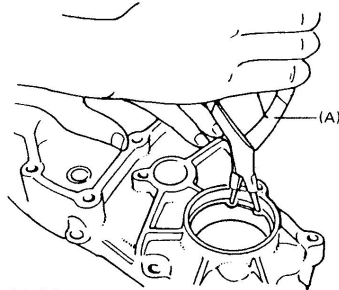
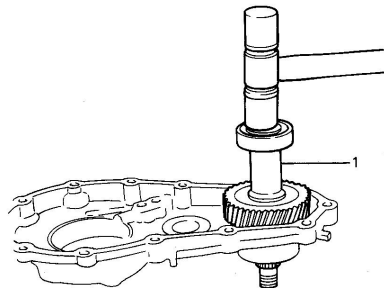

Fig. 14-30

- 2) Install input shaft to center case.



1. Input shaft

Fig. 14-31

- 3) After greasing O ring on counter shaft, insert shaft into center case and secure shaft with lock plate and bolt.

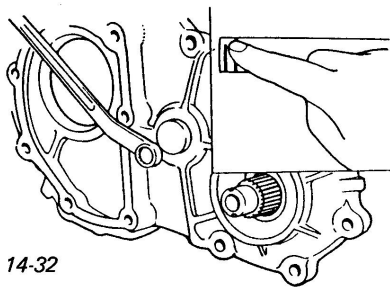

Fig. 14-32

Counter shaft lock plate bolt	N-m	kg-m	lb-ft
	9 - 17	0.9 - 1.7	7.0 - 12.0

- 4) Install the counter shaft thrust washer to center case. For installation, apply ample amount of grease to both faces of the washer so as to lubricate sliding surfaces and prevent it from moving out of place or slipping off and bring its face without depressions against center case, and fit its bent portion into groove in case securely.

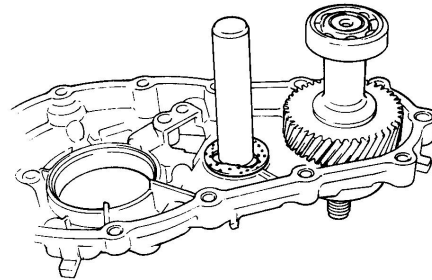

Fig. 14-33

- 5) Install needle roller bearings, spacer and counter gear on counter shaft.

1. Needle roller bearing
2. Spacer
3. Counter gear

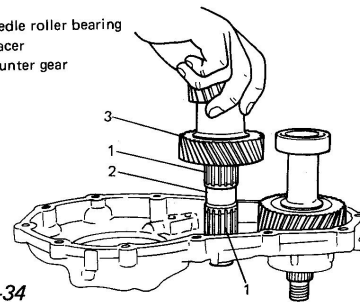
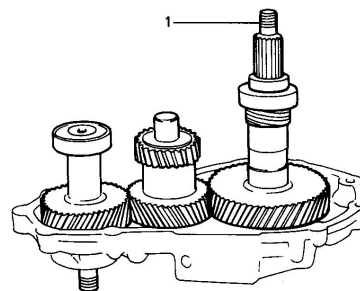

Fig. 14-34

- 6) Install output shaft assembly to center case.



1. Output shaft

Fig. 14-35

Center and Rear Cases

- 1) Check center case (or rear case) to ensure that it is provided with 2 dowel pins 1.

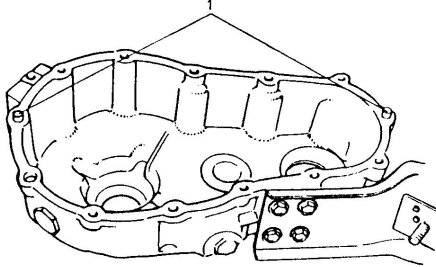

Fig. 14-36

1. Dowel pins

NOTE:

- Matching must be made carefully so as not to move countershaft thrust washers out of place.
- Be sure to install shims determined in previous item "Shim Adjustment of Input and Output Shafts" between input shaft rear bearing and rear case and between output shaft rear bearing and rear case.

- 2) Put gasket on center case. Bring rear case and center case into match and apply uniform force gradually all around rear case with a plastic hammer.

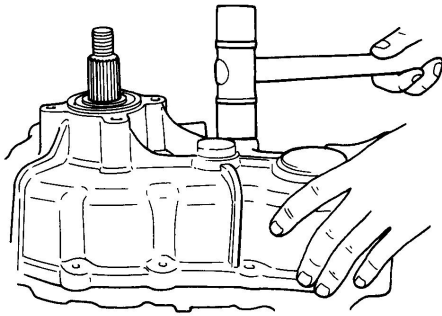

Fig. 14-37

- 3) Put gasket on center case.
- 4) Install front case to center case.
- 5) Tighten center case and output shaft front case securing bolts to specified torque.

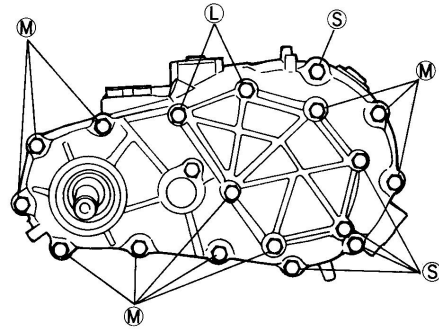

Fig. 14-38

Bolt	Length	Pieces
L	85 mm (3.35 in)	2
M	47 mm (1.85 in)	11
S	35 mm (1.38 in)	5

Tightening torque for center case and retainer bolts	N-m	kg-m	lb-ft
	13 - 23	1.3 - 2.3	9.5 - 16.5

- 6) When installing speedometer driven gear and its gear case in rear case, apply grease to O ring and oil seal lip, and align bolt hoses in rear case and driven gear case.

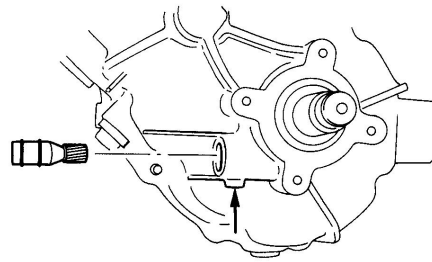

Fig. 14-39

- 7) Install propeller shaft flanges and tighten nuts to specified torque and calk the nuts.

Tightening torque for universal joint flange nuts	N-m	kg-m	lb-ft
	110-150	11.0-15.0	80-108.0

8) Upon completion of entire assembly work, install transfer in chassis body in reverse sequence of removal. Pour gear oil into transfer gear box. Refer to information given in next oil and oil capacity for oil to be used and specified amount.

NOTE:

When installing oil filler and drain plugs to transfer case, apply sealant (SUZUKI BOND No. 1215, 99000-31110) to thread part of plug.

14-9. MAINTENANCE SERVICES

Oil Level

Oil level must be checked with vehicle held in horizontal position in both front to rear and side to side directions.

Oil level plug and oil filler plug are one and the same as shown in figure.

If oil flows out of filler plug hole or if oil level is found up to hole when plug is removed, amount of oil is appropriate. Replenish oil if noted as insufficient.

Oil and Oil Capacity

Whenever vehicle is lifted up for any service including oil change, make sure to check around transfer gear box for oil leakage. Correct defects, if any, and change or refill oil.

Transfer oil capacity	0.8 litre (1.7/1.4 US/Imp. pt)
Transfer oil specification	Gear oil SAE 80W-90, 75W-80 or 75W-90

It is highly recommended to use SAE 75W-90 gear oil.

For viscosity chart, refer to '88 MODEL SERVICE MANUAL at the page 1-20.

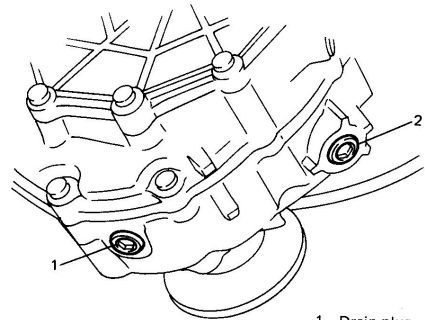



- 1. Drain plug
- 2. Oil level and oil filler plug

Fig. 14-40

14-10. TIGHTENING TORQUE

Fastening parts	N-m	lb-ft
	kg-m	
Output shaft front case bolt	13 – 23	9.5 – 16.5
	1.3 – 2.3	
Center case bolt	13 – 23	9.5 – 16.5
	1.3 – 2.3	
Counter shaft lock plate bolt	9 – 17	7.0 – 12.0
	0.9 – 1.7	
Universal joint flange nut	110 – 150	80.0 – 108.0
	11.0 – 15.0	
Transfer mounting bracket bolt	18 – 28	13.5 – 20.0
	1.8 – 2.8	
Transfer mounting nut	25 – 35	18.5 – 25.0
	2.5 – 3.5	
Cross joint bolt & nut	50 – 60	36.5 – 43.0
	5.0 – 6.0	
Oil filler and drain plug	18 – 28	13.5 – 20.0
	1.8 – 2.8	

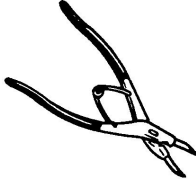
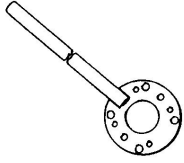
14-11. SPECIAL TOOLS

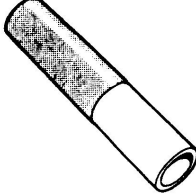
 <p>09900-06108 Snap ring pliers (closing type)</p>	 <p>09922-66020 Flange holder</p>
 <p>09913-75810 Transfer bearing installer</p>	 <p>09926-58010 Bearing puller attachment (transfer)</p>
 <p>09913-84510 Transfer bearing installer</p>	

14-12. REQUIRED SERVICE MATERIALS

MATERIALS	RECOMMENDED SUZUKI PRODUCT	USE
Lithium grease	SUZUKI SUPER GREASE A (99000-25010)	<ul style="list-style-type: none"> • Sliding and rubbing surface of components where application is instructed in this manual. • Both surfaces of counter shaft thrust washer. • Oil seal lips.
Sealant	SUZUKI BOND No. 1215 (99000-31110)	<ul style="list-style-type: none"> • Oil filler and drain plugs.

SECTION 15

PROPELLER SHAFTS

NOTE:

This model uses only No. 1 and No. 3 of the propeller shafts used for the 4WD Model. No. 1 propeller shaft transmits drive from the transmission to the transfer gear box. No. 3 shaft extends from the transfer gear box to the rear axle.

Also, dimensions and other details of these propeller shafts are the same as those of the 4WD Model. Therefore, for the removal and installation of propeller shafts and disassembly and assembly of universal joint, refer to the same section in GROUP 1.

15

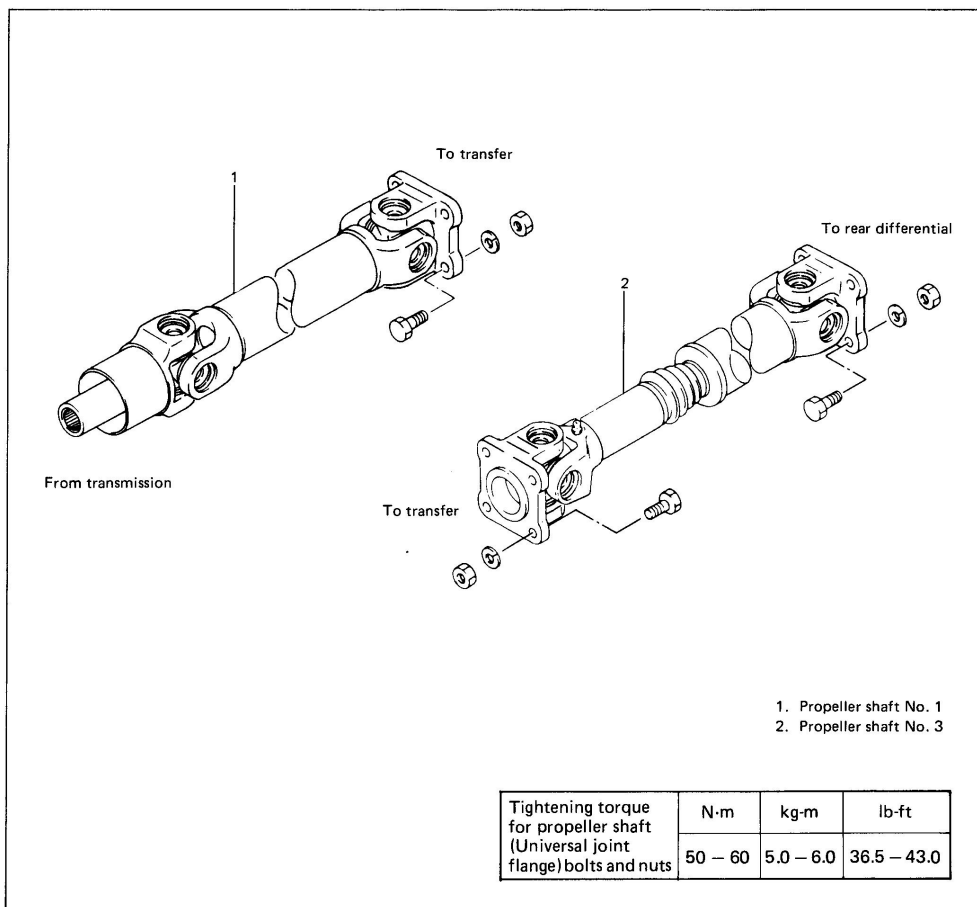

Fig. 15-1

15-1

SECTION 16

DIFFERENTIAL

NOTE:

This 2WD Model is equipped with the rear differential only and not the front differential. For servicing procedures of the rear differential including its removal, installation, dis-assembly, assembly, inspection and adjustment, refer to the same section in GROUP 1.

SECTION 17

SUSPENSION

CONTENTS

17-1. FRONT SUSPENSION	17- 2
17-2. REAR SUSPENSION	17-13
17-3. MAINTENANCE SERVICES	17-14
17-4. RECOMMENDED TORQUE SPECIFICATIONS	17-19
17-5. REQUIRED SERVICE MATERIALS	17-20

NOTE:

- All suspension fasteners are an important attaching part in that it could affect the performance of vital parts and systems, and/or could result in major repair expense. They must be replaced with one of the same part number or with an equivalent part if replacement becomes necessary. Do not use a replacement part of lesser quality or substitute design. Torque values must be used as specified during reassembly to assure proper retention of this part.
- Never attempt to heat, quench or straighten any suspension part. Replace it with a new part, or damage to the part may result.
- The leaf spring number or shape shown in this manual may differ from the vehicle being actually serviced, depending on specification.

17-1. FRONT SUSPENSION

GENERAL DESCRIPTION

The front suspension consists of the double-acting shock absorbers, stabilizer bar, semi-elliptical leaf springs, axle housing, etc. as shown below.

The end of the dead axle sleeve is in the shape of dish. This dish is rotatably fitted into the knuckle structure to form a flexible connection, the sliding clearance between the two being sealed with a felt packing (against road dust and mud) and also with an oil seal (against the oil inside). The upper and lower kingpins, bolted to the knuckle extend into the knuckle and, inside, are held by the dish-like inner case through tapered roller bearings.

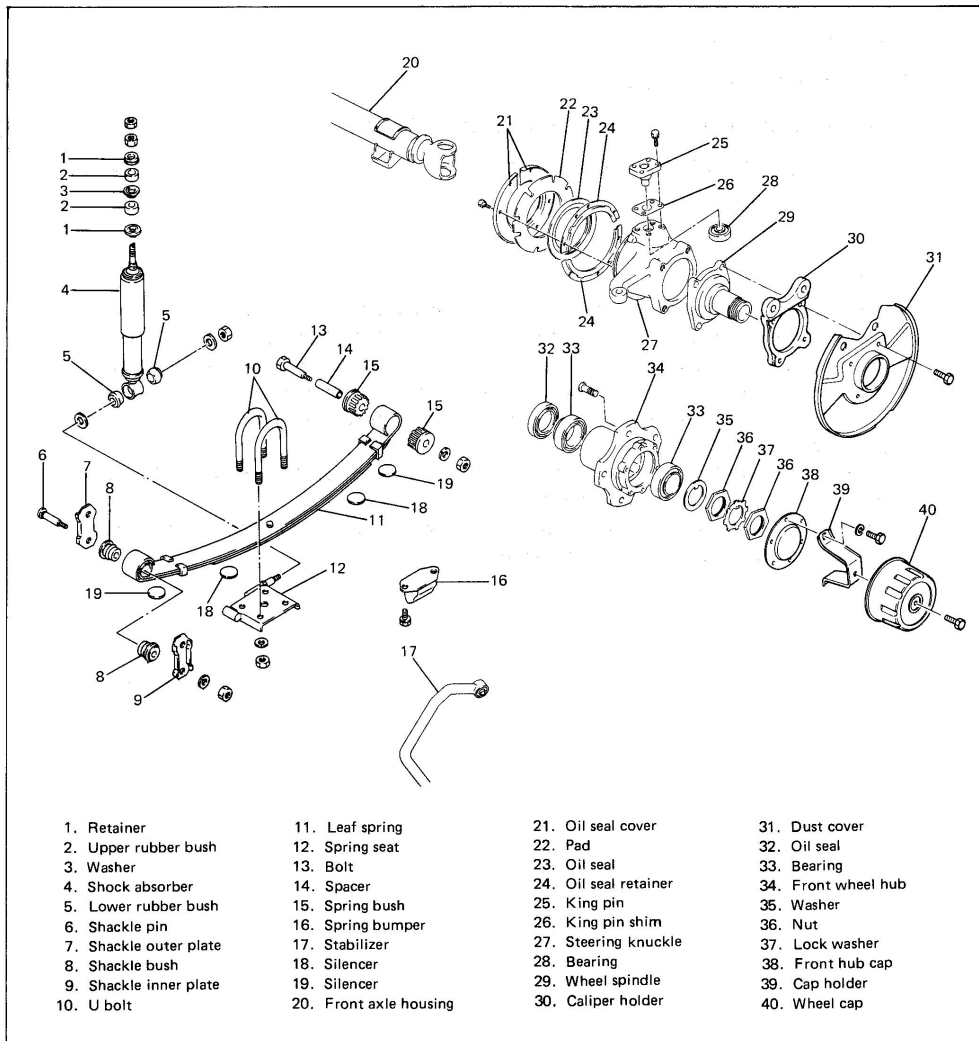
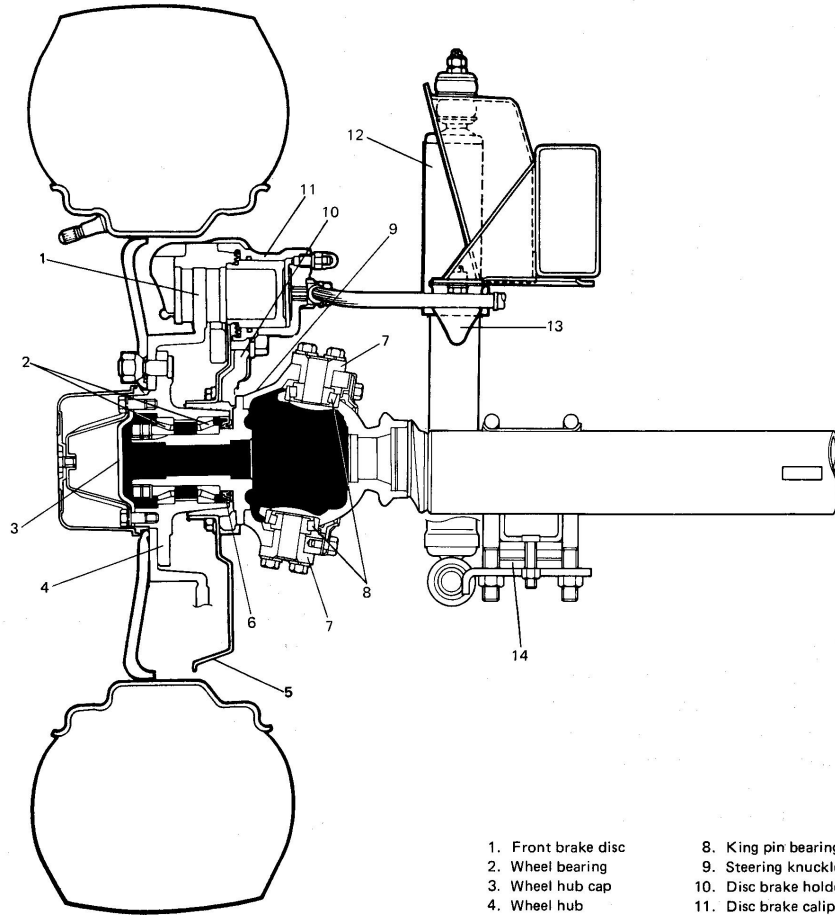

Fig. 17-1-1

17-2



- | | |
|---------------------|------------------------|
| 1. Front brake disc | 8. King pin bearing |
| 2. Wheel bearing | 9. Steering knuckle |
| 3. Wheel hub cap | 10. Disc brake holder |
| 4. Wheel hub | 11. Disc brake caliper |
| 5. Dust cover | 12. Shock absorber |
| 6. Oil seal | 13. Spring bumper |
| 7. King pin | 14. Leaf spring |

Fig. 17-1-2

REMOVAL

Shock Absorber

The shock absorber is non-adjustable, non-refillable, and cannot be disassembled.

The only service the shock absorber requires is replacement when it has lost its resistance, is damaged, or leaking fluid.

- 1) Hoist vehicle.
- 2) Loosen lower and upper mounting nuts and remove shock absorber.

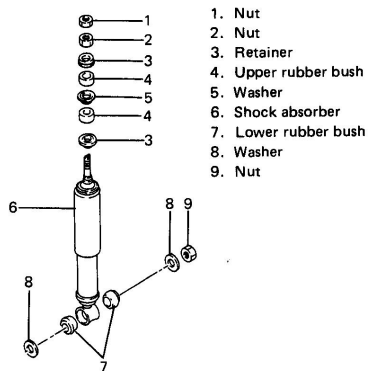

Fig. 17-1-3

Leaf Spring

- 1) Raise vehicle. In this operation, garage jack or hoist must not be positioned against front suspension related parts. When garage jack is used, place safety stands under chassis to support raised body.
- 2) Remove front wheel.
- 3) Remove stabilizer bolt.
- 4) Remove U-bolt nuts.
- 5) Remove shackle nuts and leaf spring nut.

NOTE:

Removal of leaf spring causes axle housing to hang. Support it with safety stand to prevent it from damaging universal joint of propeller shaft and others.

- 6) Pull out leaf spring bolt and remove leaf spring from shackle pin.

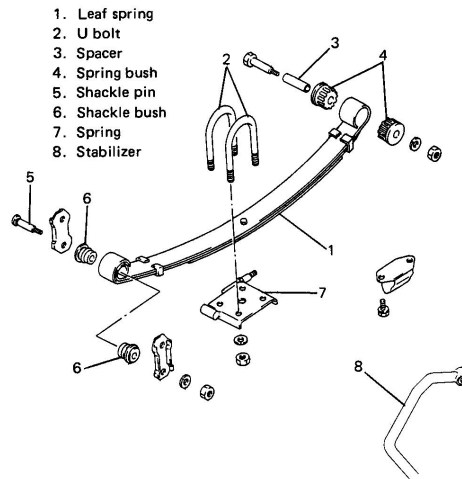

Fig. 17-1-4

Stabilizer

- 1) Hoist vehicle.
- 2) Remove stabilizer bolts.
- 3) After removing stabilizer mount bush bracket bolts, remove stabilizer.

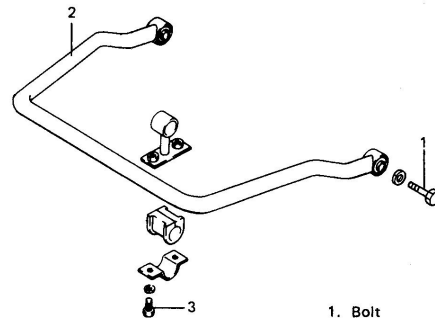

Fig. 17-1-5

Front Wheel Hub & Bearing

- 1) Remove wheel center cap.
- 2) Loosen the five nuts securing the wheel.
Raise the front end by jacking.
Rest the machine steady on safety stands.
- 3) Remove the five nuts and take off the wheel.

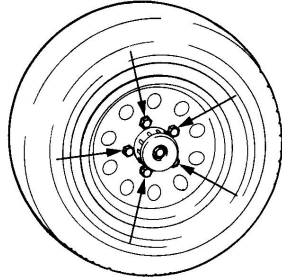

Fig. 17-1-6

- 4) Remove front wheel center cap holder and front wheel hub cap.

NOTE:

When loosening front wheel hub cap, hold front wheel by depressing footbrake pedal. This will facilitate the work.

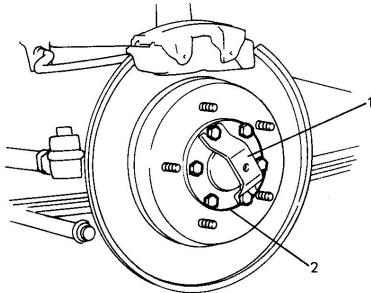

Fig. 17-1-7

1. Center cap holder
2. Axle shaft cap

- 5) Remove the caliper with carrier by loosening carrier bolts.

NOTE:

Hang removed caliper with a wire hook or the like so as to prevent brake hose from bending and twisting excessively or being pulled.
Don't operate brake pedal with caliper removed.

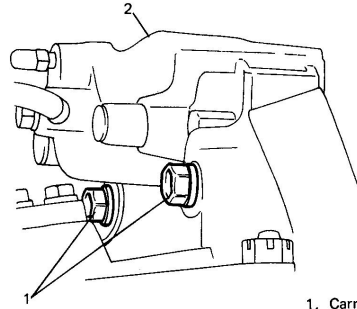

1. Carrier bolts
2. Caliper

Fig. 17-1-8

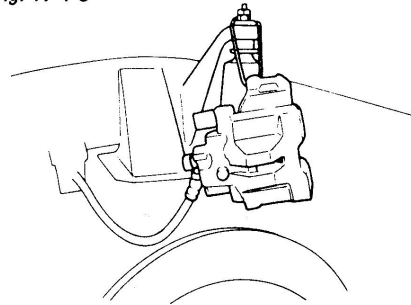
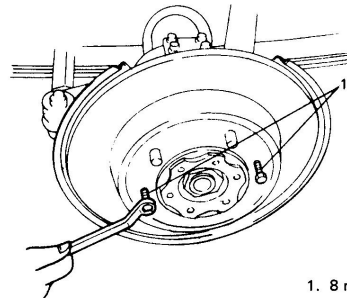

Fig. 17-1-9

- 6) Remove brake disc.

NOTE:

If brake disc can not be removed by hand, use 8 mm bolts as shown below.



1. 8 mm bolt

Fig. 17-1-10

- 7) Straighten bent part of lock washer and remove wheel bearing lock nut with special tool (B). Then remove lock washer.

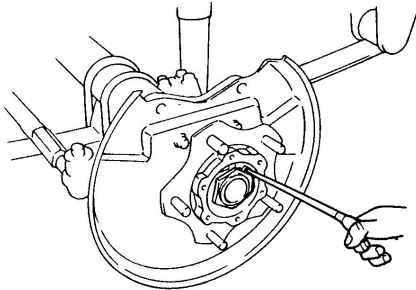

Fig. 17-1-11

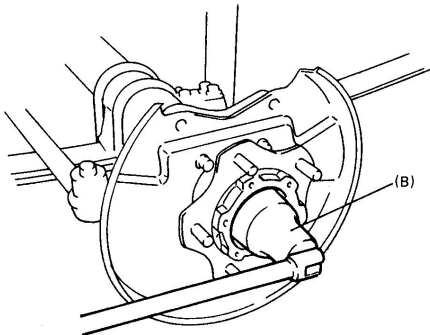

Fig. 17-1-12 Special Tool (B)
(Front Wheel Bearing Nut Socket Wrench 09941-58010)

- 8) After loosening front wheel bearing nut with the same special tool (B), take nut off the front wheel spindle.

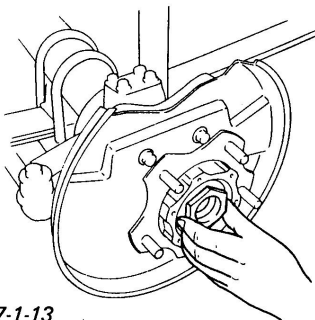

Fig. 17-1-13

17-6

- 9) Pull front wheel hub off the front wheel spindle.

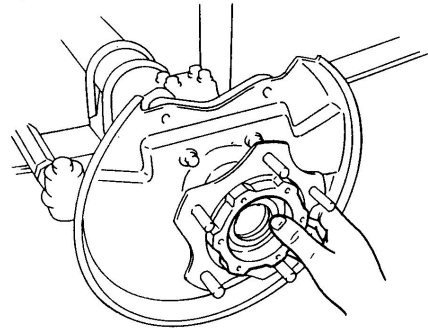

Fig. 17-1-14

- 10) Remove oil seal and outer race of inner bearing or outer bearing from wheel hub.

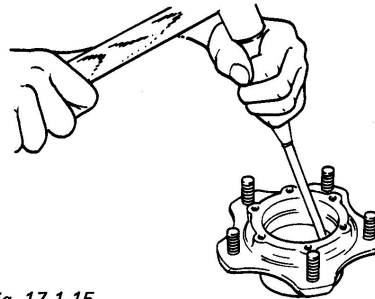

Fig. 17-1-15

Steering Knuckle

- 1) Remove front wheel hub, referring to steps 1 to 9 of foregoing front wheel hub and bearing removal.
- 2) Loosen bolts securing kingpins (upper & lower). At this point, king pins mustn't be removed.

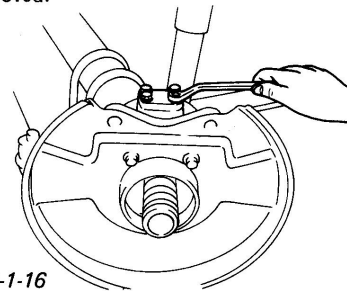

Fig. 17-1-16

3) Remove disc dust cover, caliper holder and wheel spindle.

NOTE:

Wheel spindle can be removed by tapping it with a plastic hammer.

If it does not come off easily, remove steering knuckle and then tap on inside of steering knuckle.

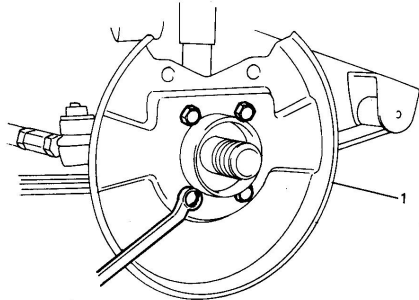

1. Dust cover

Fig. 17-1-17

4) Remove tie rod end castle nut and disconnect tie rod end from steering knuckle with special tool (A).

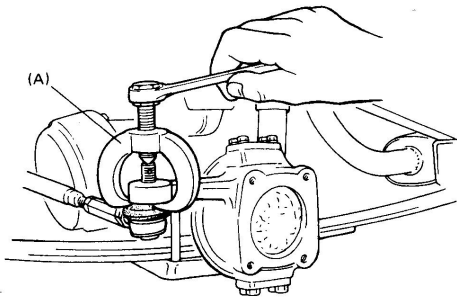

Fig. 17-1-18 Special Tool (A) (Tie Rod End Remover 09913-65210)

5) Remove joint seal bolts. Then remove oil seal cover, pad, oil seal and retainer from knuckle.

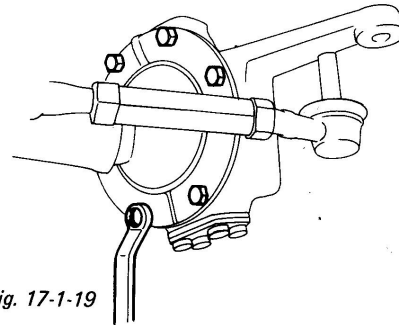
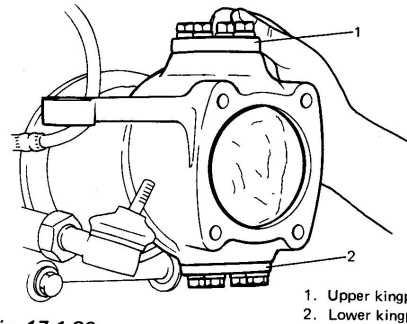

Fig. 17-1-19

6) Remove lower and upper kingpins.

NOTE:

- Upper and lower kingpins, when removed, must be marked off one from the other.
- Also make sure to check the number of kingpin shims that were fitted on each side.



1. Upper kingpins
2. Lower kingpins

Fig. 17-1-20

7) Pull off steering knuckle.

NOTE:

- When steering knuckle is pulled, lower kingpin bearing sometimes falls off. So remove bearing while pulling off the knuckle gradually.
- Upper and lower kingpin bearings must be also marked off one from the other.

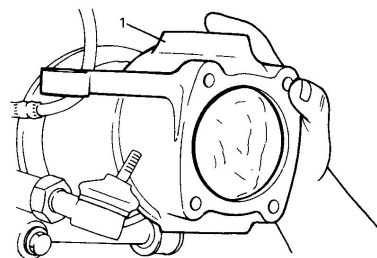

1. Steering knuckle

Fig. 17-1-21

INSPECTION OF COMPONENT

Stabilizer and its Bush

Inspect stabilizer for damage or deformation. If defective, replace.

Inspect bushes for damage, wear or deterioration. If defective, replace.

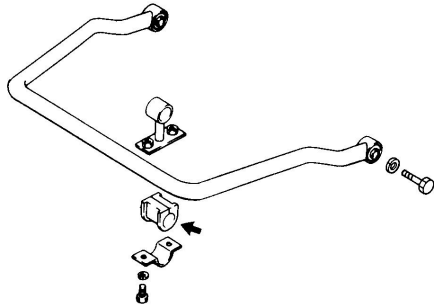

Fig. 17-1-22

Leaf Spring Bushes

Inspect for wear and breakage. If found defective, replace.

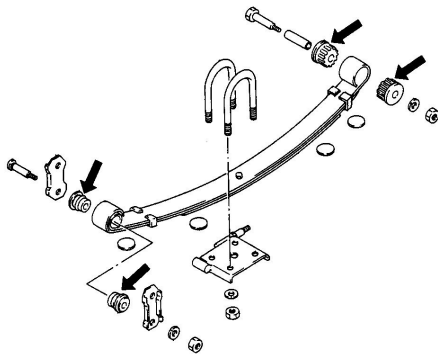

Fig. 17-1-23

Front Wheel Bearing

Check front wheel bearing rollers for damage. If anything is found wrong, replace bearing with a new one.



Fig. 17-1-24

17-8

Kingpins and Bearings

Inspect each kingpin closely for dents, signs of cracking, distortion or any other damage. Replace the kingpins found in defective condition.

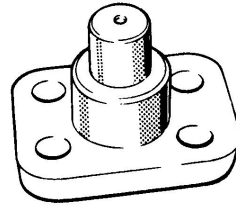

Fig. 17-1-25

Check the kingpin bearings for damage. If anything is found wrong, replace the bearing with new one.

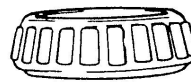

Fig. 17-1-26

Steering Knuckle Oil Seal

The oil seal used at the spherical sliding joint between the knuckle and the inner case accomplishes the additional purposes of keeping out road dust and of acting as the damper for the steering handwheel. As the wear of this seal advances, its damping effect decreases and thus make the front wheel develop a tendency to "shimmy" not only that road dust begins to creep into the sliding clearance to promote the wear of the spherical sliding surfaces.

Check the oil seal for wear or damage. If defective, replace with new one.

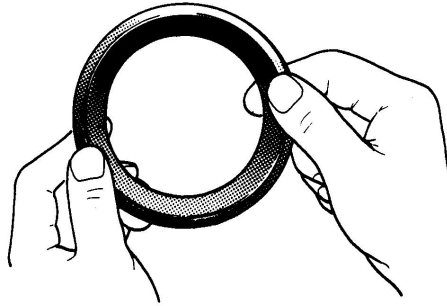

Fig. 17-1-27

INSTALLATION

Reverse removal procedure observing each precaution.

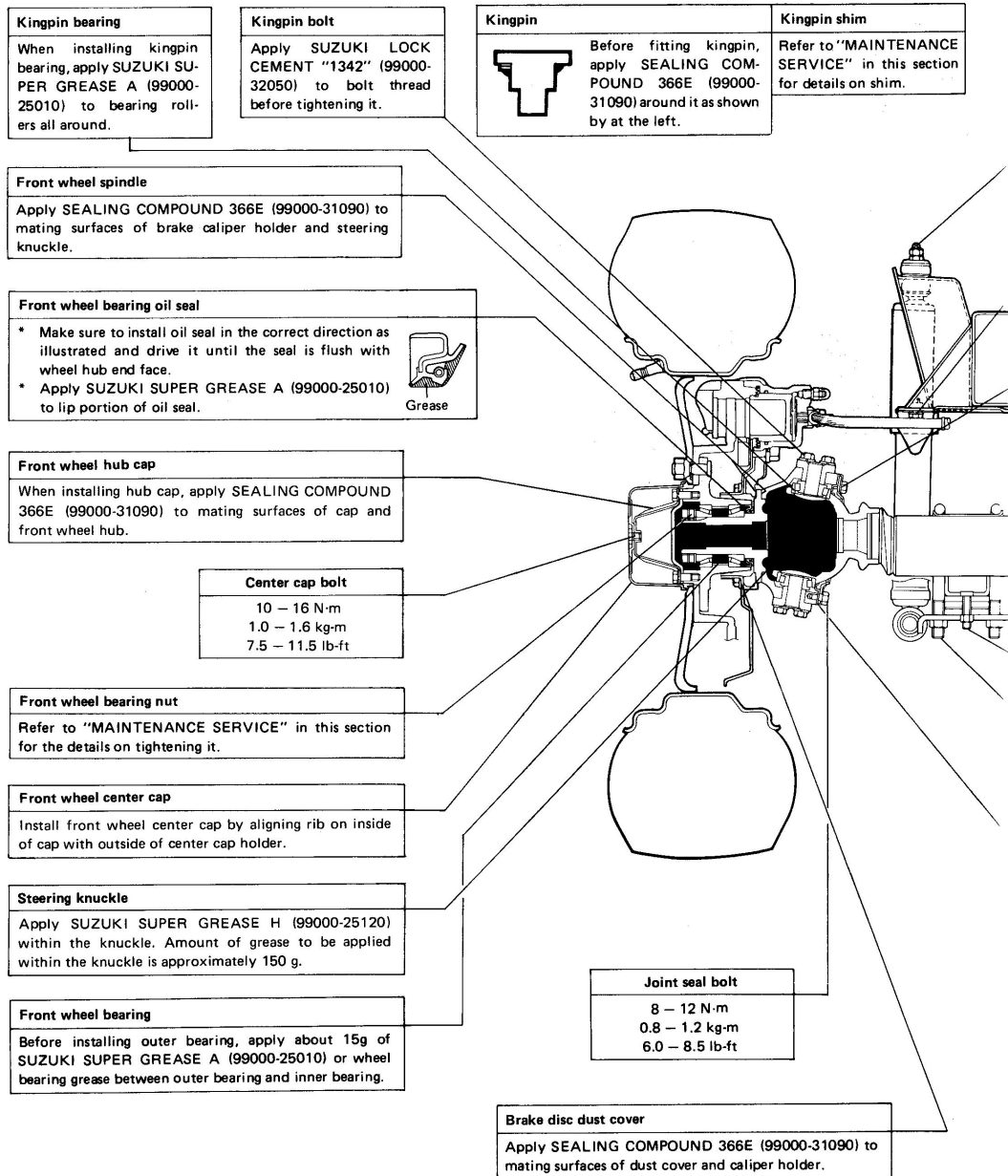

Fig. 17-1-28

17-10

Shock absorber lock nut
 22 – 35 N·m
 2.2 – 3.5 kg·m
 (16.0 – 25.0 lb·ft)

Spring bumper bolt
 18 – 28 N·m
 1.8 – 2.8 kg·m
 (13.5 – 20.0 lb·ft)

Front leaf spring bush & spring bolt

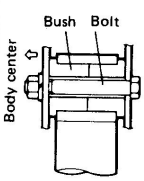

Body center
 Bush Bolt

- Either water or household type detergent may be used to press-fit the bush onto spring. But oil of any kind is strictly prohibited.
- Insert both right and left bolts from the outside into the inside of body.

Steering knuckle oil seal



Grease

Before installing oil seal, apply SUZUKI SUPER GREASE H (99000-25120) to its lip portion.

Front leaf spring shackle plate

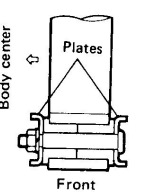

Body center
 Plates
 Front

Install plates with their backs directed to each other.

When installing front axle housing, position it in such way that vehicle manufacturing date stamp on it faces vehicle front.



Front leaf spring shackle pins & bush

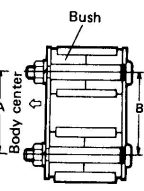

Body center
 Bush
 A
 B

- Insert both right and left pins from outside into inside of body.
- Tighten nuts to specified torque in unloaded state.
- When pins are inserted, make sure that the difference (A – B) is within $-0.3 \sim +0.3$ mm ($-0.024 \sim +0.024$ in).
- Either water or household type detergent may be used to press-fit bush onto spring. But oil of any kind is strictly prohibited.

Leaf spring center bolt & nut

Insert bolt and nut securely into holes of axle housing seat and spring seat.

Front spring U bolt

When securing U bolt, tighten its front and rear nuts evenly.

Shock absorber & nut

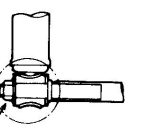

For correct installing direction of absorber washer, refer to the figure.

35 – 55 N·m
 3.5 – 5.5 kg·m
 (25.5 – 39.5 lb·ft)

Oil seal retainer

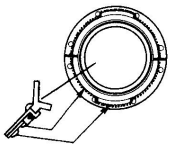

When installing retainer, apply SEALING COMPOUND 366E (99000-31090) all around it.

NOTE:
 Torque specifications of other bolts and nuts are given under "RECOMMENDED TORQUE SPECIFICATIONS" of this section.

Stabilizer

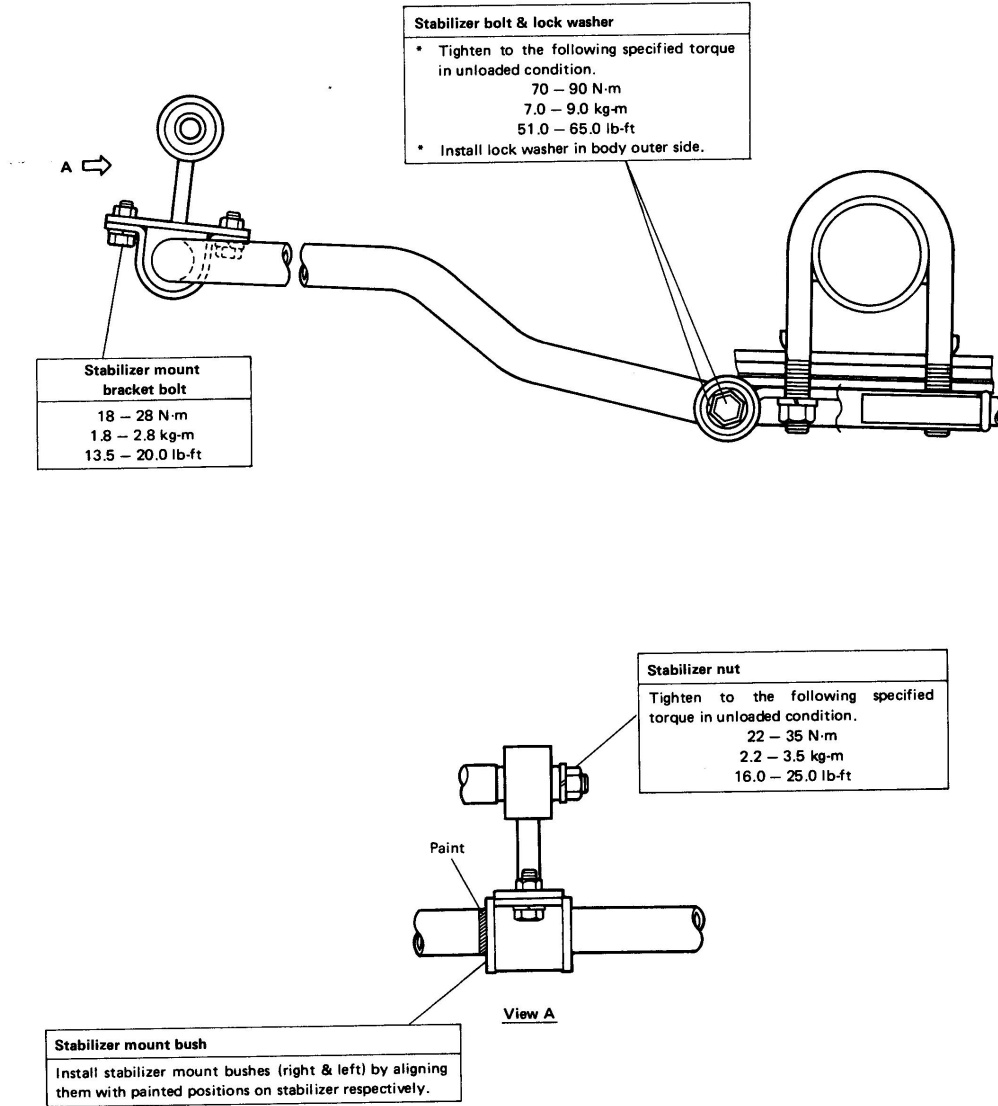

Fig. 17-1-29

17-2. REAR SUSPENSION

GENERAL DESCRIPTION

The rear suspension consists of leaf springs, axle housing, axle shafts and shock absorbers as shown below. The leaf springs are attached to the chassis frame through rubber bushes located at their both ends as shown. The axle housing is installed on the right and left leaf springs by means of spring seats and U bolts. The two shock absorbers (right & left) are installed with their lower ends attached to the spring seats and the upper ends to the chassis frame, all through rubber bushes.

NOTE:

The structure of this rear suspension is the same as that of the 4WD Model except the spring rate of the rear leaf spring.

Also, servicing procedures of the rear suspension, such as removal, installation and maintenance, are the same as the 4WD Model. Therefore, refer to the same section in GROUP 1.

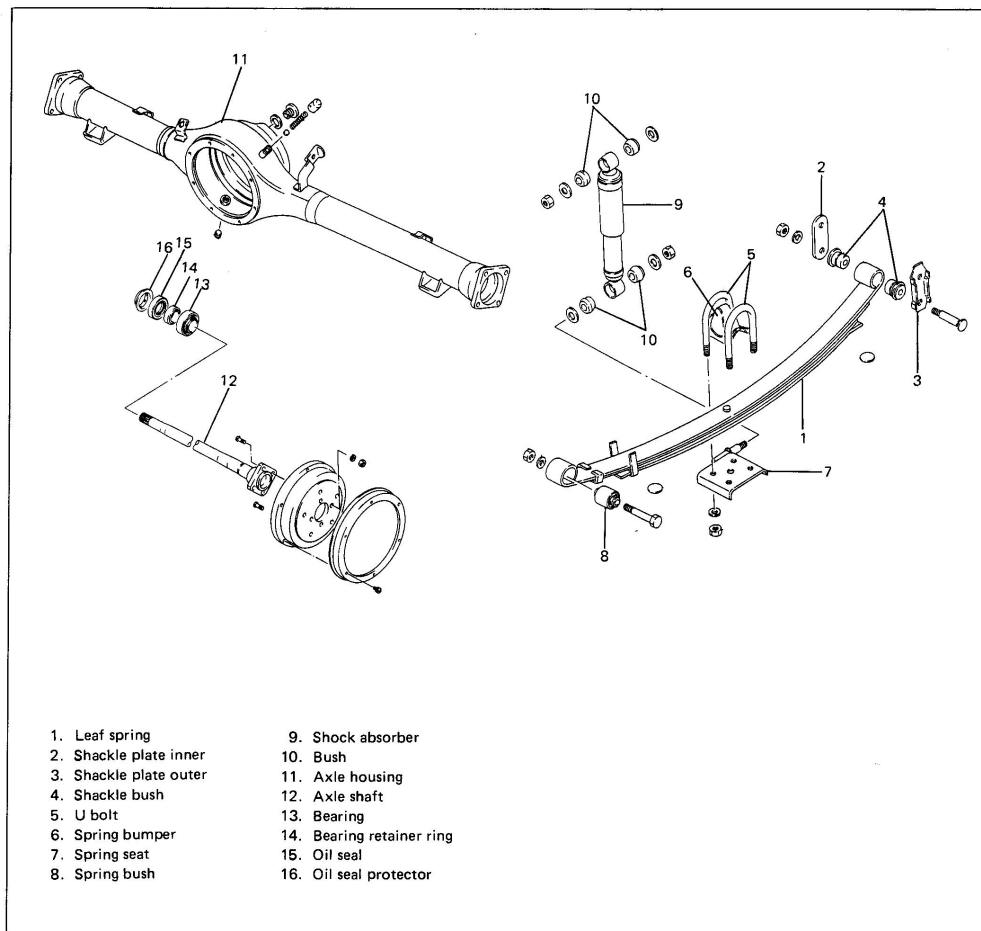

Fig. 17-2-1

17-3. MAINTENANCE SERVICES

Shock Absorber

- 1) Inspect for deformation or damage.
- 2) Inspect bushings for wear or damage.
- 3) Inspect for evidence of oil leakage.

Replace any defective part.

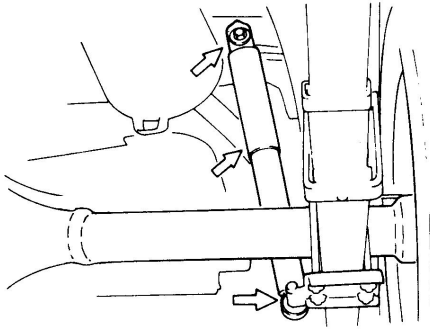

Fig. 17-3-1

WARNING:

When handling rear shock absorber in which high-pressure gas is sealed, make sure to observe the following precautions.

- 1) Don't disassemble it.
- 2) Don't put it into the fire.
- 3) Don't store it where it gets hot.
- 4) Before disposing it, be sure to drill a hole in it where shown by an arrow in the figure below and let gas and oil out. Lay it down sideways for this work.

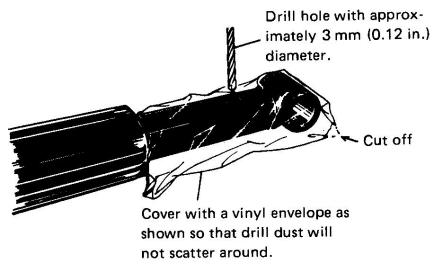

Fig. 17-3-2

Leaf Spring and Bumper

- 1) Inspect leaf spring for crack, wear and damage.

NOTE:

Special attention must be paid to that part as indicated by "A" in figure below (where each end of the shorter leaf contacts).

- 2) Inspect bumper for damage. If found defective, replace.

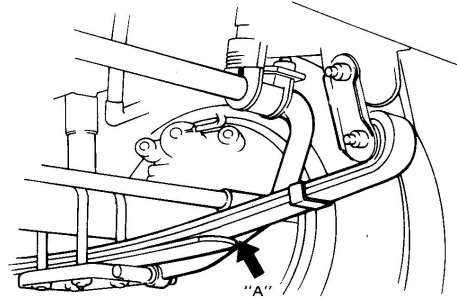

Fig. 17-3-3

Rear Wheel Bearing

- 1) Check wheel bearings for wear. When measuring thrust play, apply a dial gauge to drum center.

Thrust play Limit	Rear	0.8 mm (0.03 in.)
-------------------	------	-------------------

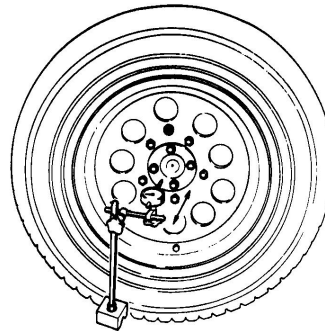

Fig. 17-3-4

When measurement exceeds limit, replace bearing.

- 2) By rotating wheel actually, check wheel bearing for noise and smooth rotation. If it is defective, replace bearing.

Front Wheel Bearing :

[Inspection]

- 1) To check wheel bearings, jack up front end. Spin wheel and check if it is spun smoothly and is free from abnormal noise. If it isn't, replace wheel bearing.

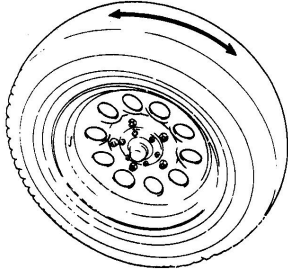

Fig. 17-3-5

- 2) Upon completion of the check in above 1), check each joint of steering system for tightness, each ball stud of the steering link as well as each kingpin for rattle. Then check bearing as described below.
- 3) Shake wheel in the direction indicated by an arrow in figure below to see if bearing rattles.

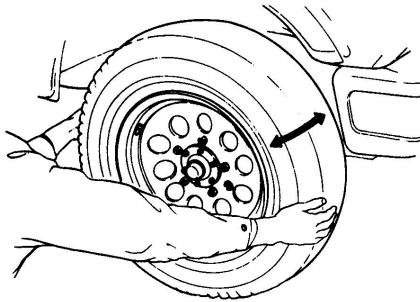

Fig. 17-3-6

- 4) Shake wheel in the direction indicated by an arrow in figure below to see if bearing rattles.

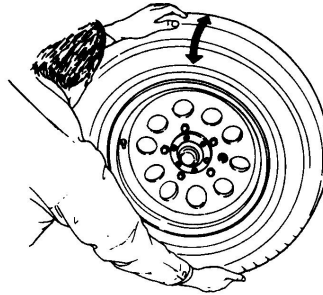

Fig. 17-3-7

- 5) If bearing rattles, check bearing preload with wheel and brake caliper & holder removed as shown in figure below.

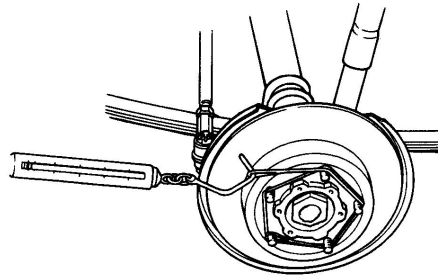

Fig. 17-3-8

Wheel bearing starting preload	2.0 – 3.0 kg (4.4 – 6.6 lb)
--------------------------------	--------------------------------

If preload is not within the above specification, adjust bearing preload according to following "adjustment".

[Adjustment]

- 1) After removing wheel bearing lock nut and lock washer, tighten bearing nut ① to the torque of 80 N·m (8.0 kg·m, 57.5 lb-ft) while spinning hub by hand. Next, loosen the nut until the torque becomes 0 N·m (0. kg·m, 0 lb-ft) and then tighten it again to tightening torque specified below.
In this way, an appropriate bearing preload is obtained.

Wheel bearing nut ① tightening torque	10.0 – 15.0 N·m 1.0 – 1.5 kg·m (7.5 – 10.5 lb-ft)
--	---

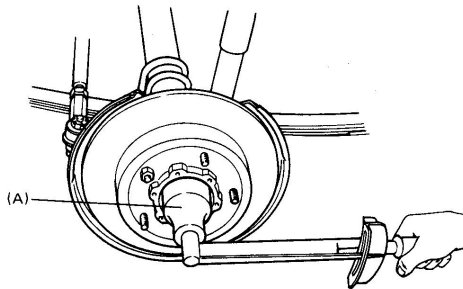
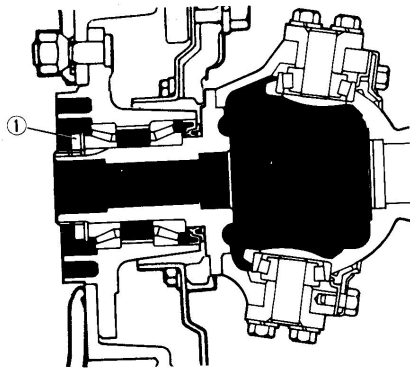

Fig. 17-3-9 Special Tool (A) (Front Wheel Bearing Nut Socket Wrench 09941-58010)



1. Wheel bearing lock nut

Fig. 17-3-10

- 2) Be sure to insert lock washer after adjustment and tighten lock nut ② to specified torque. Then bend a part of lock washer toward bearing nut (body side) and another part toward lock nut (outside) so that these 2 nuts are locked.

Wheel bearing lock nut ② tightening torque	60 – 90 N·m 6.0 – 9.0 kg·m (43.5 – 65.0 lb-ft)
---	--

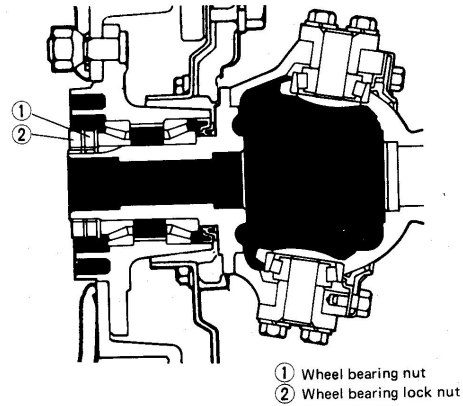

① Wheel bearing nut
② Wheel bearing lock nut

Fig. 17-3-11

- 3) Recheck that bearing starting preload is within specification.
- 4) Upon completion of adjustment, be sure to install wheel hub cap, disc brake caliper & holder and wheel.
Refer to "INSTALLATION" in this section.

King Pin

[Inspection and adjustment]

Where tapered roller bearings holding 2 kingpins at each front wheel are in good and properly preloaded (tightened) condition, there will be no appreciable rattle of wheel. To check kingpins and their tapered roller bearings, jack up the front end and shake wheel to feel any rattle, as shown in figure. If rattle is felt, eliminate it by properly decreasing the shim thickness. The shim is located between flanged part of kingpin and knuckle.

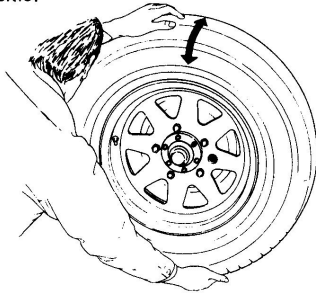

Fig. 17-3-12

The above-mentioned method of making a shim adjustment demands a high degree of skill on the part of the serviceman. The alternative method is to adjust shim thickness by referring to the torque resistance which knuckle arm offers when pulled in the condition shown in figure. For this method, the reference torque value is established as indicated below, and you are to increase or decrease shim thickness to produce this torque value.

NOTE:

After removing wheel and steering knuckle oil seal and disconnecting tie rod end, this checking and adjustment should be carried out.

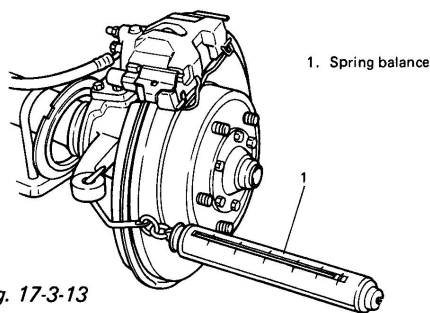

Fig. 17-3-13

Before giving a test pull to knuckle arm with a spring balance in the alternative method, install a large amount of shims on each kingpin to lighten preload on tapered roller bearing. Keep on reading the torque, each time decreasing shim thickness a little, and continue this process until specified torque value is obtained. (This process protects kingpins because it ensure that no excessive pull will be applied to bearings at the onset.) If the process fails to produce specified torque, that is, if desired torque resistance does not occur even when shim thickness has been reduced to zero on each kingpin, it means that bearings or kingpins are excessively worn and need replacement.

NOTE:

- Read spring balance indication when knuckle arm begins to turn. In other words, you are to read "starting torque."
- When checking knuckle arm starting torque, be sure to have axle hub oil seal removed and tighten kingpin bolts to specified torque.

Knuckle arm starting torque (force)	1.0 – 1.8 kg (2.20 – 3.96 lb) without oil seal
Available sizes of shim fork kingpins	0.1, 0.5 mm (0.004, 0.02 in.)

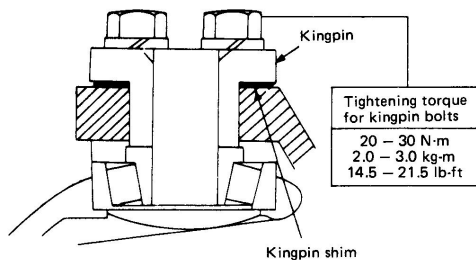

Fig. 17-3-14

Upon completion of this check and/or adjustment, be sure to connect tie rod end to steering knuckle and install oil seal retainer, oil seal, felt packing oil seal cover and wheel.

Refer to "INSTALLATION" in this section.

Steering Knuckle Oil Seal

The oil seal used at the spherical sliding joint between knuckle and inner case accomplishes additional purposes of keeping out road dust and of acting as the damper for steering hand-wheel. As wear of this seal advances, its damping effect decreases and thus makes front wheel develop a tendency to "shimmy" not only that road dust begins to creep into sliding clearance to promote wear of spherical sliding surfaces.

The oil seal is an expendable item, and must be replaced at regular intervals.

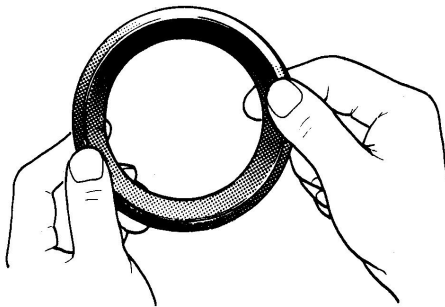

Fig. 17-3-15

[How to replace oil seal]

- 1) Remove 8 bolts securing joint seat, and displace oil seal cover and felt packing inward.

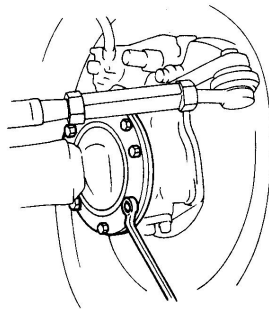

Fig. 17-3-16

- 2) Cut oil seal in place with scissors or a knife, and take it off.
- 3) Cut replacement oil seal at one place with scissors or a knife as shown in figure below.
- 4) Install the seat in oil seal retainer, bringing the cut portion to top side and locating it about 30 degrees off the matching face of oil seal retainer.

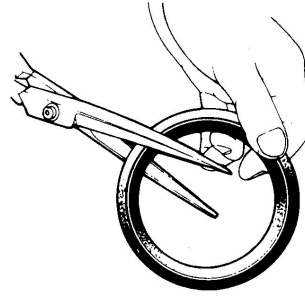

Fig. 17-3-17

- 5) Apply grease to inside of oil seal. Apply sealing compound to mating face all around: this is for preventing entry of water.

- SEALING COMPOUND "CEMEDINE" 366E (99000-31090)
- SUZUKI SUPER GREASE H (99000-25120)

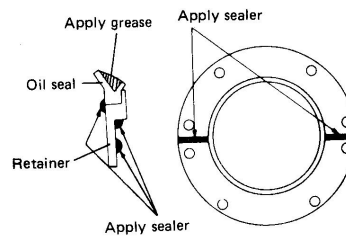

Fig. 17-3-18

- 6) Tighten joint seat securing bolts to specified torque.

17-4. RECOMMENDED TORQUE SPECIFICATIONS

Fastening parts	Tightening torque		
	N·m	kg·m	lb·ft
Schackle pin nut	30 – 55	3.0 – 5.5	22.0 – 39.5
Leaf spring nut	60 – 85	6.0 – 8.5	43.5 – 61.0
Leaf spring U bolt nut	60 – 80	6.0 – 8.0	43.5 – 57.5
Wheel nut	80 – 110	8.0 – 11.0	57.5 – 79.5
Front wheel hub cap	10 – 16	1.0 – 1.6	7.5 – 11.5
Kingpin upper & lower bolts	20 – 30	2.0 – 3.0	14.5 – 21.5
Joint seal bolt	8 – 12	0.8 – 1.2	6.0 – 8.5
Front & rear shock absorber lower nut	35 – 55	3.5 – 5.5	22.5 – 39.5
Front shock absorber upper lock nut	22 – 35	2.2 – 3.5	16.0 – 25.0
Front leaf spring bumper bolt	18 – 28	1.8 – 2.8	13.5 – 20.0
Stabilizer bolt	70 – 90	7.0 – 9.0	51.0 – 65.0
Stabilizer nut	22 – 35	2.2 – 3.5	16.0 – 25.0
Stabilizer mount bracket bolt	18 – 28	1.8 – 2.8	13.5 – 20.0
Front wheel bearing nut	10 – 15	1.0 – 1.5	7.5 – 10.5
Front wheel bearing lock nut	60 – 90	6.0 – 9.0	43.5 – 65.0
Rear differential oil drain plug	18 – 25	1.8 – 2.5	13.5 – 18.0
Rear differential oil filler & level plug	35 – 50	3.5 – 5.0	25.5 – 36.0
Wheel center cap bolt	10 – 16	1.0 – 1.6	7.5 – 11.5

17-5. REQUIRED SERVICE MATERIALS

MATERIALS	RECOMMENDED SUZUKI PRODUCT	USE
Lithium grease	SUZUKI SUPER GREASE (A) (99000-25010)	<ul style="list-style-type: none">• Kingpin bearing.• Front wheel bearing.• Lip portion of front wheel bearing oil seal.
Lithium soap grease containing molybdenum disulfide	SUZUKI SUPER GREASE (H) (99000-25120)	<ul style="list-style-type: none">• Steering knuckle.• Lip portion of steering knuckle oil seal.
Thread lock cement	SUZUKI LOCK CEMENT "1342" (09900-32050)	<ul style="list-style-type: none">• Kingpin bolt.
Sealing compound	SUZUKI SEALING COMPOUND 366E (99000-31090)	<ul style="list-style-type: none">• Kingpin.• To matching surfaces of steering knuckle, brake caliper holder, wheel spindle, and dust cover.• Steering knuckle oil seal retainer.• Wheel hub cap.

SECTION 18

STEERING SYSTEM

NOTE:

The same description of steering system structure and operation as well as its service information applies to the 2WD Model as the 4WD Model except the shape of the differential housing of the front axle housing. Therefore, when servicing the steering system of the 2WD Model, refer to the same section in GROUP 1.

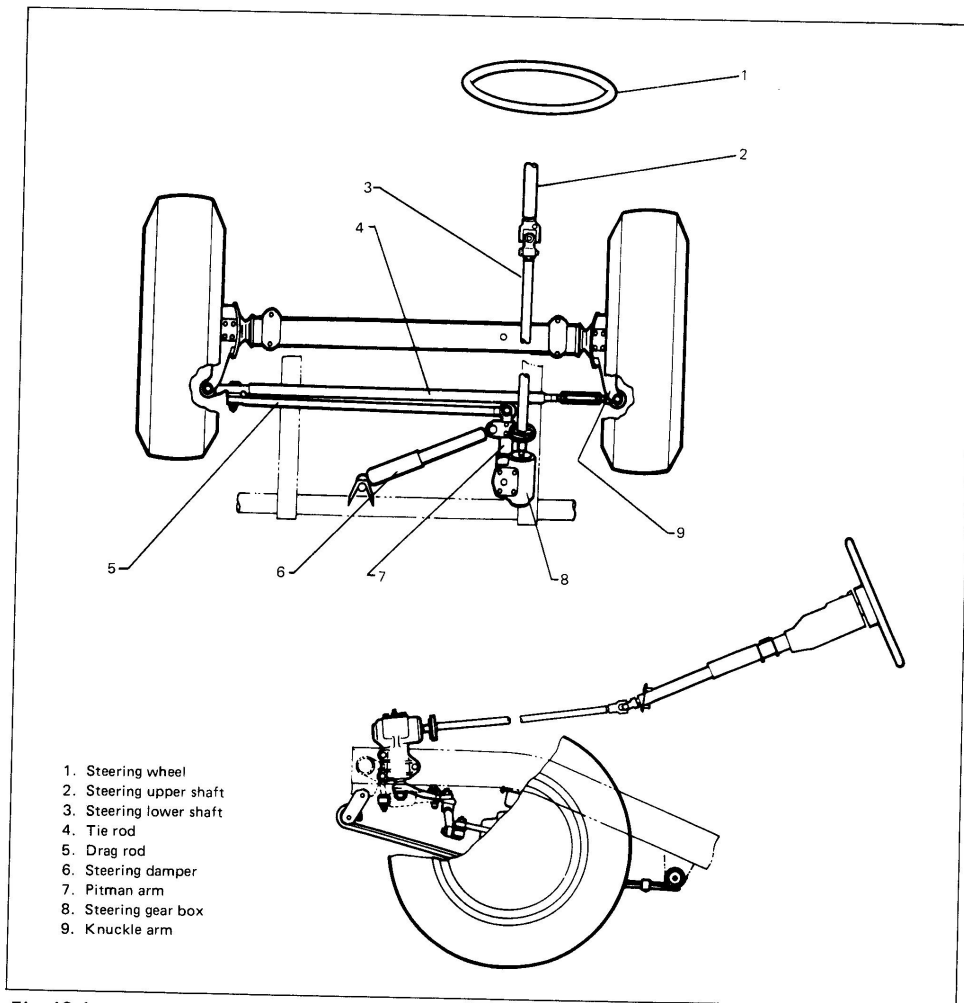

Fig. 18-1

SECTION 22

SERVICE DATA

NOTE:

For the items not found in this section, refer to the same section in GROUP 1.

CONTENTS

22-1. SPECIFICATIONS 22-1
 22-2. SERVICE DATA 22-2

22-1. SPECIFICATIONS

	Models	Convertible/Hard Top
POWER TRANSMISSION		
Clutch type		Dry, single disc
Transmission type		5-forward all synchromesh, 1 reverse
Final reduction ratio (Differential)		3.727
Transmission gear ratios	low	3.652
	2nd	1.947
	3rd	1.423
	4th	1.000
	5th	0.864
	reverse	3.466
Transfer gear ratios		1.409
Overall reduction ratios	low	19.177
	2nd	10.224
	3rd	7.472
	4th	5.251
	5th	4.537
	reverse	18.201
WHEEL AND SUSPENSION		
Tire size: front and rear		P195/75 R15
Tire pressure	front	140 kPa (1.40 kg/cm ² , 20 psi)
	rear	140 kPa (1.40 kg/cm ² , 20 psi)-unladen
		180 kPa (1.80 kg/cm ² , 26 psi)-laden

22-2. SERVICE DATA

SUSPENSION

	Item	Standard	Service Limit
Suspension	Front wheel bearing starting preload	2.0 ~ 3.0 kg (4.4 ~ 6.6 lbs.)	_____
	Rear wheel bearing thrust play	_____	0.8 mm (0.03 in.)
	Knuckle arm starting torque (without oil seal)	1.0 ~ 1.8 kg (2.20 ~ 3.96 lbs.)	_____

GROUP 2

Prepared by

SUZUKI MOTOR CORPORATION

Automobile Department
Overseas Service Division

1st Ed. July, 1990
2nd Ed. May, 1991

Printed in Japan

GROUP 3

1994

SUZUKI

Samurai

SUPPLEMENTARY SERVICE MANUAL



FOREWORD

This supplementary service manual (GROUP 3) has been prepared for the SAMURAI 1994 MODEL.

It describes different service information of 1994 MODEL as compared with 1993 MODEL.

Therefore, whenever servicing 1994 MODEL, consult GROUP 3 first. And for any section, item or description not found in GROUP 3, refer to GROUP 1.

All information, illustrations and specifications contained in this literature are based on the latest product information available at the time of publication approval. And used as the main subject of description is the vehicle of standard specifications among others. Therefore, note that illustrations may differ from the vehicle being actually serviced. The right is reserved to make changes at any time without notice.

TABLE OF CONTENTS

	SECTION
PERIODIC MAINTENANCE SERVICE	1
ELECTRONIC FUEL INJECTION SYSTEM	4 A

GROUP 3

SUZUKI MOTOR CORPORATION

*AUTOMOBILE DEPARTMENT
OVERSEAS SERVICE DIVISION*

© COPYRIGHT SUZUKI MOTOR CORPORATION 1993

SECTION 1

PERIODIC MAINTENANCE SERVICE

1

NOTE:

For the descriptions (items) not found in this section, refer to the same section in GROUP 1.

CONTENTS

1-1. MAINTENANCE SCHEDULE	1-2
Normal driving condition schedule	1-2
Maintenance recommended under severe driving conditions . . .	Refer to GROUP 1.
1-2. ENGINE AND EMISSION CONTROL	1-4
2. Camshaft timing belt replacement and inspection	1-4
3. Valve lash inspection	1-4
4. Engine oil and filter change	1-4

1-1

1-1. MAINTENANCE SCHEDULE

1-2

NOTE:

For Federal Specification Vehicles except Californian and Canadian Specification Vehicles, the "CHECK ENGINE" light in the combination meter lights at the mileage of 50,000, 80,000 and 100,000 miles each of which is detected by the mileage sensor. Upon completion of maintenance service of items (8, 9, 10, 11, 13, 14 & 25) required for each mileage, be sure to turn off the "CHECK ENGINE" light cancel switch, referring to SECTION 4A (p. 4A-16) of GROUP 1. Then the mileage sensor will be reset.

	miles (x 1,000)		30		45		60		75		82.5		90		97.5		105		112.5		120	
	7.5	15	22.5	30	37.5	45	52.5	60	67.5	75	82.5	90	97.5	105	112.5	120						
	km (x 1,000)		50		75		100		125		137.5		150		162.5		175		187.5		200	
	months		15		22.5		30		37.5		45		52.5		60		67.5		75		82.5	
ENGINE & EMISSION CONTROL																						
1. Fan (Water pump) drive belt	-	-	-	-	-	-	-	-	-	-	-	-	-	-	-	-	-	-	-	-	-	-
2. Camshaft timing belt	-	-	-	-	-	-	-	-	-	-	-	-	-	-	-	-	-	-	-	-	-	-
3. Valve lash (clearance)	-	-	-	-	-	-	-	-	-	-	-	-	-	-	-	-	-	-	-	-	-	-
4. Engine oil and oil filter	R	R	R	R	R	R	R	R	R	R	R	R	R	R	R	R	R	R	R	R	R	R
5. Cooling system hoses and connections	-	-	-	**I	-	-	-	-	-	-	-	-	-	-	-	-	-	-	-	-	-	-
6. Engine coolant	-	-	-	**R	-	-	-	-	-	-	-	-	-	-	-	-	-	-	-	-	-	-
7. Exhaust pipes and mountings	-	-	-	**I	-	-	-	-	-	-	-	-	-	-	-	-	-	-	-	-	-	-
8. PCV valve	-	-	-	-	-	-	-	-	I&(R)	-	-	-	-	-	-	-	-	-	-	-	-	I&(R)
9. Oxygen sensor	Replace at 50,000 miles (83,000 km) and 100,000 miles (166,000 km)																					
10. Catalytic converter	Replace at 80,000 miles (133,000 km)																					
11. Charcoal canister	Inspect at 100,000 miles (166,000 km)																					
12. Emission-related hoses & tubes	Replace at 100,000 miles (166,000 km)																					
*13. EGR system	-	-	-	-	-	-	-	-	-	-	-	-	-	-	-	-	-	-	-	-	-	-
14. ECM & associated sensors	Inspect at 50,000 miles (83,000 km) and 100,000 miles (166,000 km)																					
15. Wiring harness and connections	Inspect at 100,000 miles (166,000 km)																					
IGNITION SYSTEM																						
16. Spark plugs	-	-	-	-	-	-	-	-	-	-	-	-	-	-	-	-	-	-	-	-	-	-
17. Distributor cap and rotor	-	-	-	R	-	-	-	-	-	-	-	-	-	-	-	-	-	-	-	-	-	R
18. Ignition wiring	-	-	-	-	-	-	-	-	-	-	-	-	-	-	-	-	-	-	-	-	-	-
19. Ignition timing	-	-	-	-	-	-	-	-	-	-	-	-	-	-	-	-	-	-	-	-	-	-

NOTES:

- R : Replace or change
- I : Inspect and correct or replace if necessary.
- * Item 5 **I, Item 6 **R and Item 7 **I are recommended maintenance items.
- * Item 7 (R) is applicable to exhaust mounting rubber only.
- * Item **13 EGR system inspection is a recommended maintenance item for Canadian Specification vehicles although it is one of periodical inspection items for any other specification vehicles.

Interval: This interval should be judged by odometer reading or months, whichever comes first.	miles (x 1,000)		7.5	15	22.5	30	37.5	45	52.5	60	67.5	75	82.5	90	97.5	105	112.5	120
	km (x 1,000)		12.5	25	37.5	50	62.5	75	87.5	100	112.5	125	137.5	150	162.5	175	187.5	200
	months		7.5	15	22.5	30	37.5	45	52.5	60	67.5	75	82.5	90	97.5	105	112.5	120
FUEL																		
20. Fuel tank cap						**1				R								R
21. Air cleaner filter element						R				R								R
22. Fuel filter						**R				R								R
23. Fuel lines and connections						**1												
*24. Idle speed						I				I								I
25. Fuel injector						I				I								I
Inspect at 100,000 miles (166,000 km)																		
CHASSIS AND BODY																		
26. Clutch						I				I								I
Brake discs and pads (front)						I				I								I
27. Brake drums and shoes (rear)						I				I								I
28. Brake hoses and pipes						I				I								I
29. Brake fluid						I				R								R
30. Brake pedal						I				I								I
31. Brake lever and cable						I				I								I
32. Tires						I				I								I
33. Wheel discs and free wheeling hubs (if equipped)						I				I								I
34. Steering knuckle oil seals						R				R								R
35. Wheel bearings						I				I								I
36. Shock absorbers						I				I								I
37. Propeller shafts						I				I								I
38. Transmission, transfer and differential oil						I & L				I & L								I & L
39. Leaf spring						I				R								R
40. Suspension bolts and nuts						T				T								T
41. Steering system						I				I								I
42. Door hinges						L				L								L

NOTES:

R : Replace or change
I : Inspect and correct or
replace if necessary.

T : Tighten to the specified torque

L : Lubricate

- Item 20 **1, Item 22 **R and Item 23 **1 are recommended maintenance items.
- Item *24 is recommended maintenance item.
- Item 35 *1 is applicable to not only rattled wear but also their grease.

1-2. ENGINE AND EMISSION CONTROL

For maintenance service procedure of any item not found in this section, refer to the same section of GROUP 1.

2. CAMSHAFT TIMING BELT REPLACEMENT AND INSPECTION

Refer to section 1 of GROUP 1 for its procedures.

3. VALVE LASH INSPECTION

- 1) Remove cylinder head cover.
- 2) Inspect intake and exhaust valve lash and adjust as necessary.

Valve lash (gap A) specification		When cold (Coolant temperature is 15 – 25°C or 59 – 77°F)	When hot (Coolant temperature is 60 – 68°C or 140 – 154°F)
	Intake		0.13 - 0.17 mm (0.005 - 0.007 in)
Exhaust		0.15 - 0.19 mm (0.006 - 0.008 in)	0.25 - 0.29 mm (0.010 - 0.011 in)

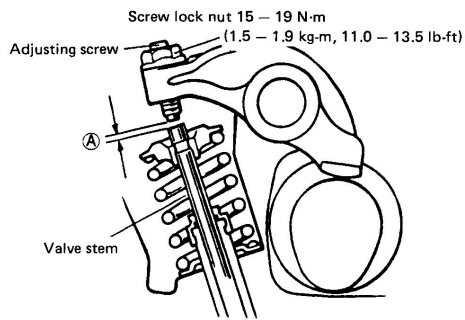

Fig. 1-3-1

- 3) Install cylinder head cover and tighten bolts to specification.

4. ENGINE OIL AND FILTER CHANGE

It is recommended to use engine oil of SG, SH or SH/ILSAC GF-1 class.

For further details, refer to section 1 of '88 MODEL SERVICE MANUAL.

SECTION 4A

ELECTRONIC FUEL INJECTION SYSTEM

4A

NOTE:

For the descriptions (items) not found in this section, refer to the same section of GROUP 1.

GENERAL DESCRIPTION

ELECTRONIC CONTROL SYSTEM

On-board diagnostic system (Self-diagnosis function)

Among the 1990 – 1993 model vehicles, only the California spec. vehicle is provided with the self-diagnosis function of the EGR system for its ECM. But with the 1994 model, ECM in all USA spec. vehicles have this function.

Therefore, in case of 1994 model, Diagnostic Trouble Code No. 51 will be displayed when an abnormality has occurred in the EGR system of USA spec. vehicle.

Be sure to bear this in mind when performing service work.

60B40-6E-1-2S

Recirculated Exhaust Gas Temperature Sensor

USA spec. vehicle is equipped with this sensor. Refer to GROUP 1 for the details.

GROUP 3

Prepared by

SUZUKI MOTOR CORPORATION

Automobile Department
Overseas Service Division

1st Ed. June, 1993

Printed in Japan

7

WIRING DIAGRAM

For USA

WIRE COLOR

B	Black
Bl	Blue
Br	Brown
G	Green
Gr	Gray
Sbl	Sky blue
Lg	Light green
Or	Orange
R	Red
W	White
Y	Yellow
P	Pink
V	Violet
B/Bl	Black with Blue tracer
B/G	Black with Green tracer
B/R	Black with Red tracer
B/W	Black with White tracer
B/Y	Black with Yellow tracer
Bl/B	Blue with Black tracer
Bl/G	Blue with Green tracer
Bl/R	Blue with Red tracer
Bl/W	Blue with White tracer
Bl/Y	Blue with Yellow tracer
Br/W	Brown with White tracer
Br/Y	Brown with Yellow tracer
G/R	Green with Red tracer
G/W	Green with White tracer
G/Y	Green with Yellow tracer
Gr/B	Gray with Black tracer
Gr/G	Gray with Green tracer
Gr/W	Gray with White tracer
Gr/R	Gray with Red tracer
Gr/Y	Gray with Yellow tracer
Lg/B	Light green with Black tracer
Lg/W	Light green with White tracer
Or/B	Orange with Black tracer
Or/Y	Orange with Yellow tracer
P/B	Pink with Black tracer
P/Bl	Pink with Blue tracer
V/Y	Violet with Yellow tracer
R/B	Red with Black tracer
R/G	Red with Green tracer
R/W	Red with White tracer
R/Y	Red with Yellow tracer
W/B	White with Black tracer
W/Bl	White with Blue tracer
W/G	White with Green tracer
W/R	White with Red tracer
W/Y	White with Yellow tracer
Y/B	Yellow with Black tracer
Y/Bl	Yellow with Blue tracer
Y/G	Yellow with Green tracer
Y/R	Yellow with Red tracer
Y/W	Yellow with White tracer

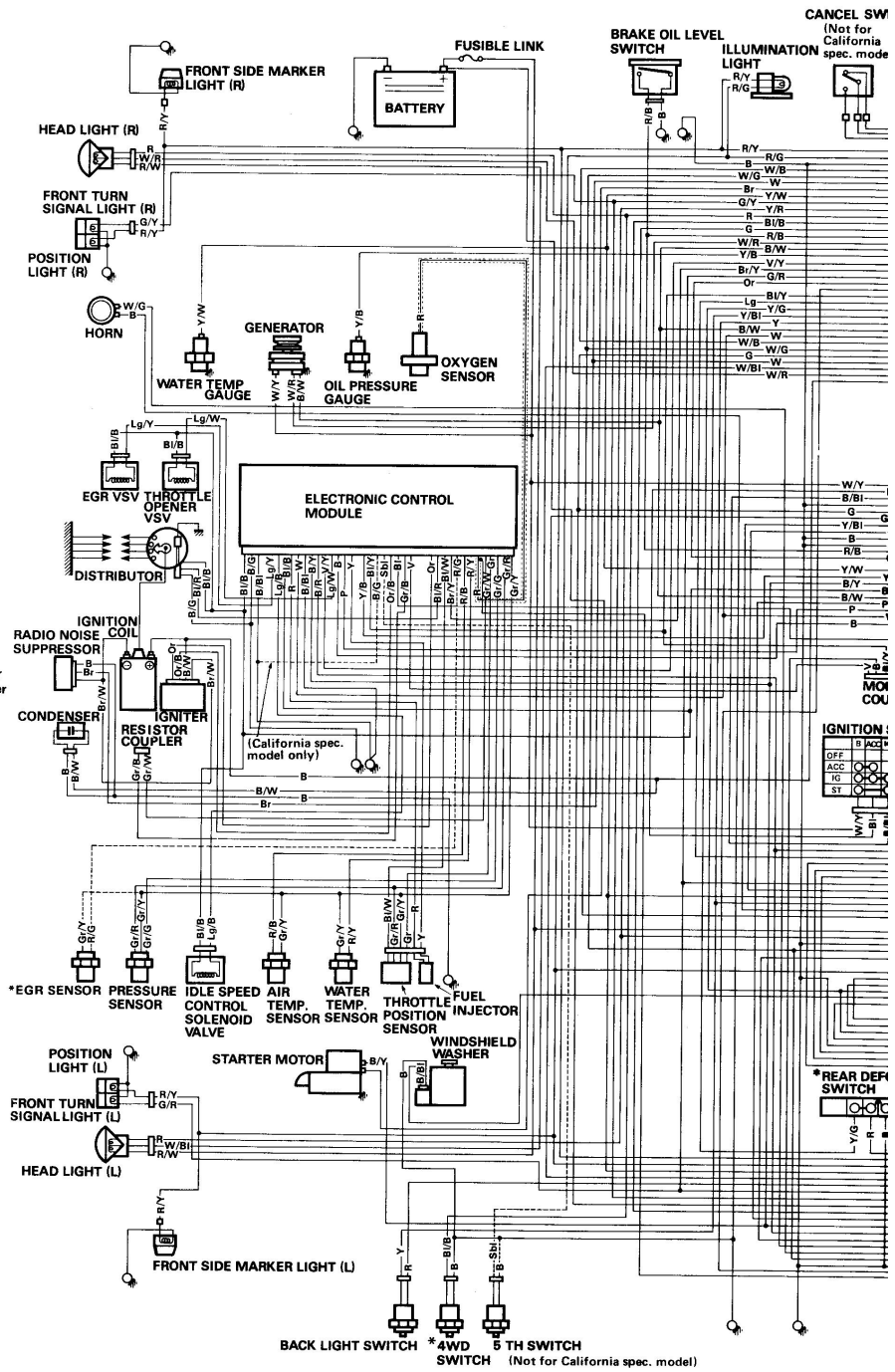

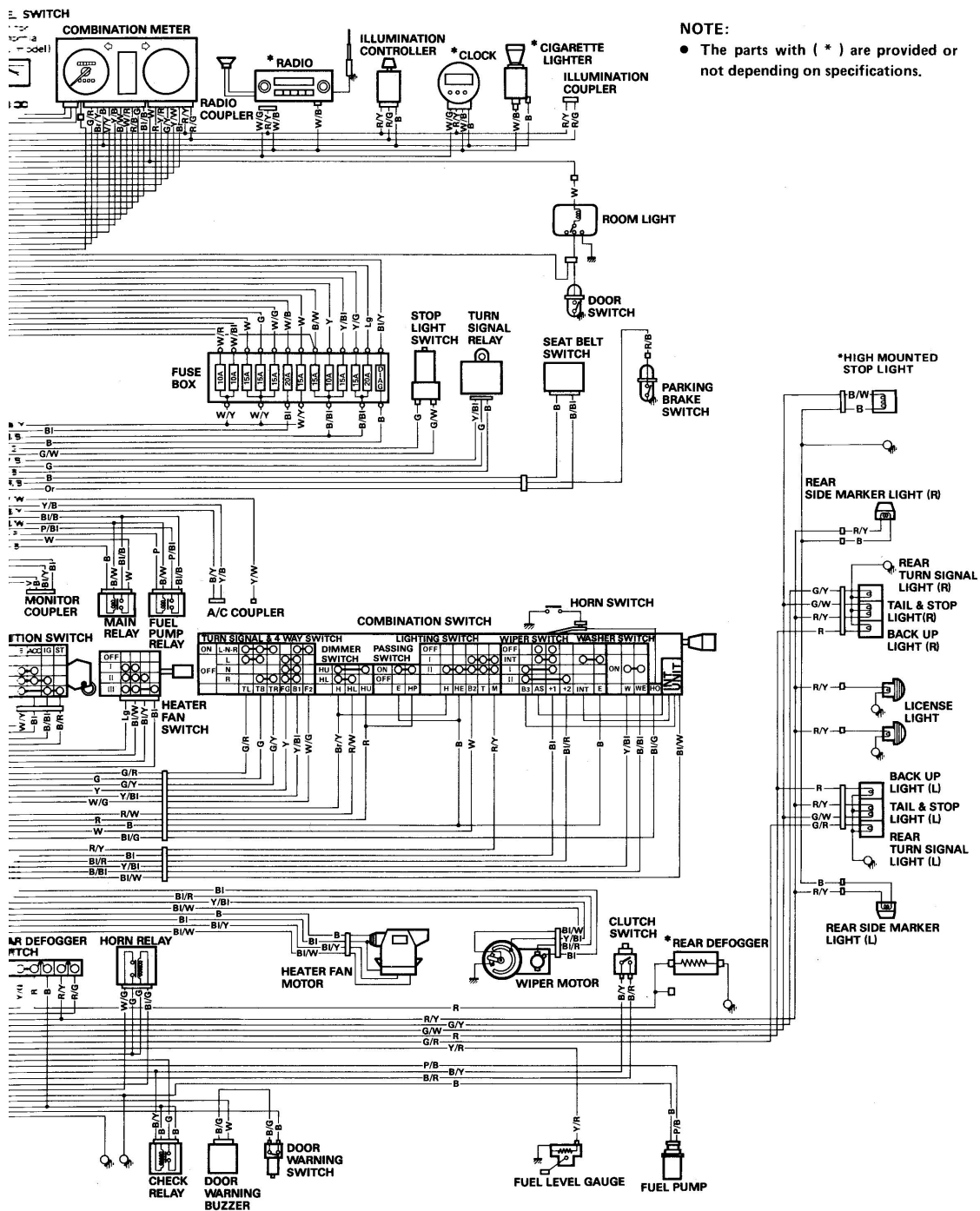

YIE17 E03, E33

For CANADA

WIRE COLOR

B	Black
Bl	Blue
Br	Brown
G	Green
Gr	Gray
Sbl	Sky blue
Lg	Light green
Or	Orange
R	Red
W	White
Y	Yellow
P	Pink
V	Violet
B/Bl	Black with Blue tracer
B/G	Black with Green tracer
B/R	Black with Red tracer
B/W	Black with White tracer
B/Y	Black with Yellow tracer
Bl/B	Blue with Black tracer
Bl/G	Blue with Green tracer
Bl/R	Blue with Red tracer
Bl/W	Blue with White tracer
Bl/Y	Blue with Yellow tracer
Br/W	Brown with White tracer
Br/Y	Brown with Yellow tracer
G/R	Green with Red tracer
G/W	Green with White tracer
G/Y	Green with Yellow tracer
Gr/B	Gray with Black tracer
Gr/G	Gray with Green tracer
Gr/W	Gray with White tracer
Gr/R	Gray with Red tracer
Gr/Y	Gray with Yellow tracer
Lg/B	Light green with Black tracer
Lg/W	Light green with White tracer
Lg/Y	Light green with Yellow tracer
Or/B	Orange with Black tracer
P/B	Pink with Black tracer
P/Bl	Pink with Blue tracer
V/Y	Violet with Yellow tracer
R/B	Red with Black tracer
R/G	Red with Green tracer
R/W	Red with White tracer
R/Y	Red with Yellow tracer
W/B	White with Black tracer
W/Bl	White with Blue tracer
W/G	White with Green tracer
W/R	White with Red tracer
W/Y	White with Yellow tracer
Y/B	Yellow with Black tracer
Y/Bl	Yellow with Blue tracer
Y/G	Yellow with Green tracer
Y/R	Yellow with Red tracer
Y/W	Yellow with White tracer

NOTE:
The parts with (*) are provided or not depending on specifications.

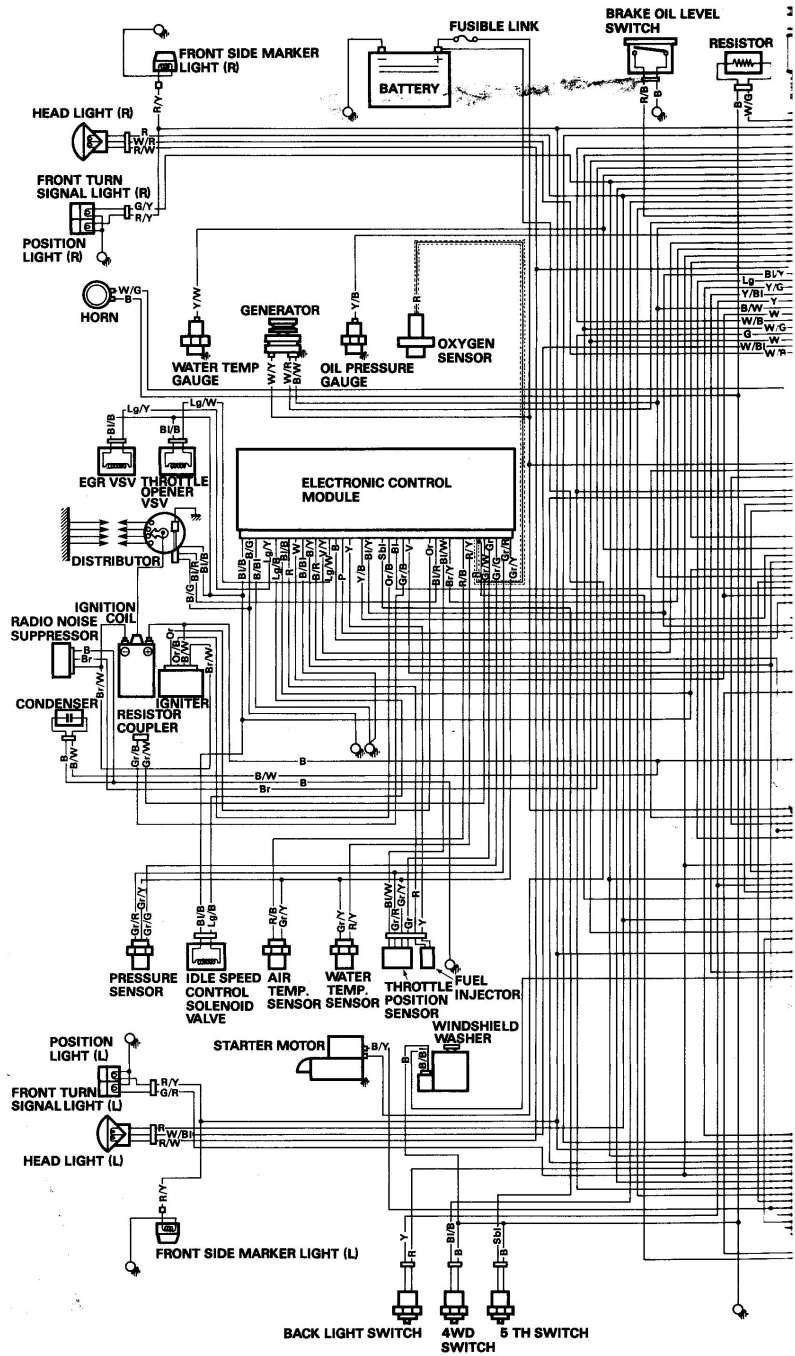

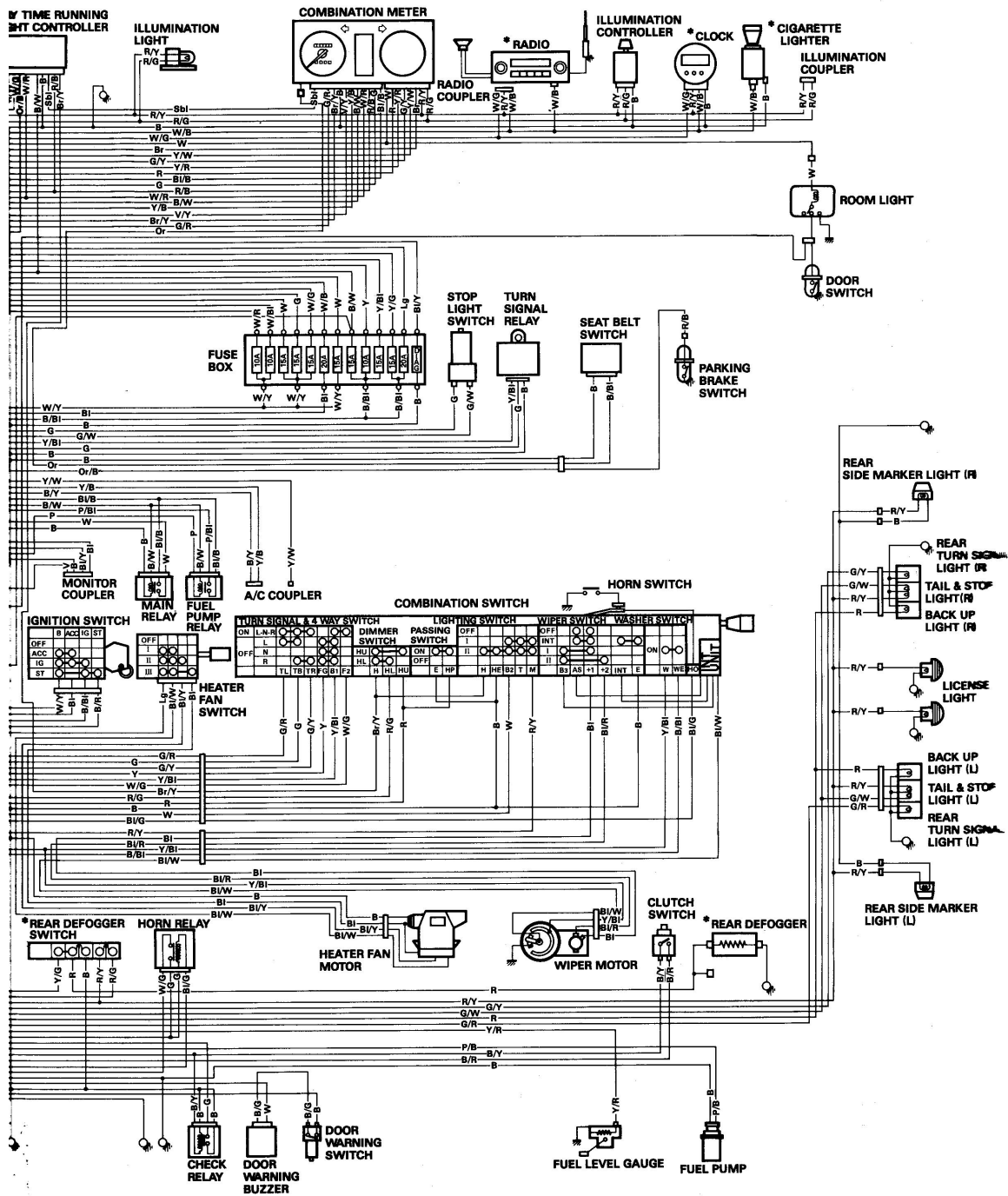

YIE17 E28

GROUP 1 - 3

Prepared by

SUZUKI MOTOR CORPORATION

Automobile Department
Overseas Service Division

1st Ed. June, 1993

Printed in Japan

Printing: June, 1993

271

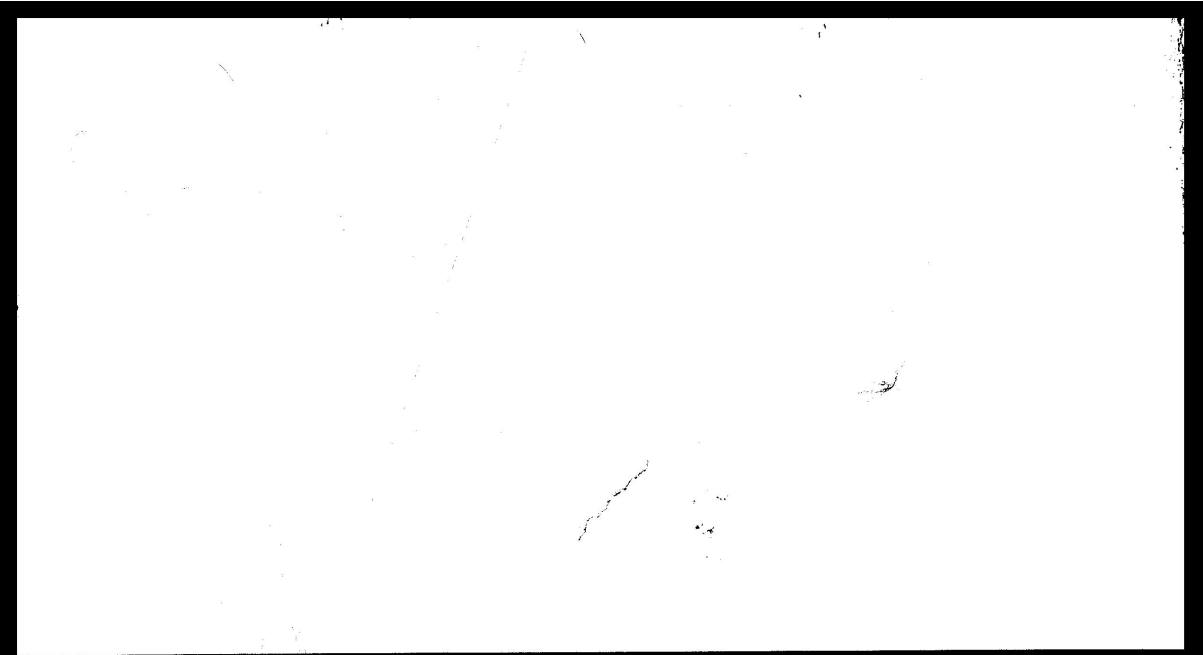

SUZUKI MOTOR CORPORATION



Printed in Japan S