

SUZUKI

GA41E

SUPPLEMENTARY SERVICE MANUAL

USE THIS MANUAL WITH MANUALS
MENTIONED IN FOREWORD OF THIS
MANUAL.

SUZUKI
Caring for Customers

99501-76A10-01E
(英)

IMPORTANT

WARNING/CAUTION/NOTE

Please read this manual and follow its instructions carefully. To emphasize special information, the words **WARNING**, **CAUTION** and **NOTE** have special meanings. Pay special attention to the messages highlighted by these signal words.

WARNING:

Indicates a potential hazard that could result in death or injury.

CAUTION:

Indicates a potential hazard that could result in vehicle damage.

NOTE:

Indicates special information to make maintenance easier or instructions clearer.

WARNING:

This service manual is intended for authorized SUZUKI dealers and qualified service mechanics only. Inexperienced mechanics or mechanics without the proper tools and equipment may not be able to properly perform the services described in this manual. Improper repair may result in injury to the mechanic and may render the vehicle unsafe for the driver and passengers.

WARNING:

For vehicles equipped with Supplemental Restraint (Air Bag) System:

- Service on or around the air bag system components must be performed only by an authorized SUZUKI dealer. Please observe all WARNINGS, CAUTIONS and "Service Precautions" under "On-Vehicle Service" in SECTION 10B before performing service on or around the air bag system components or wiring. Failure to follow WARNINGS could result in unintentional activation of the system or could render the system inoperative. Either of these two conditions may result in severe injury.
- If the air bag system and another vehicle system both need repair, SUZUKI recommends that the air bag system be repaired first, to help avoid unintentional activation of the air bag system.
- Do not modify the steering wheel, instrument panel or any other air bag system component. Modifications can adversely affect air bag system performance and lead to injury.
- If the vehicle will be exposed to temperatures over 93°C (200°F) (for example, during a paint baking process), remove the air bag system components (air bag (inflator) modules, SDM and seat belt pretensioner (if equipped)) beforehand to avoid component damage or unintended activation of the system.

FOREWORD

This SUPPLEMENTARY SERVICE MANUAL is a supplement to GA413 SERVICE MANUAL. It has been prepared exclusively for the following applicable model.

Applicable model: GA413 of and after the vehicle identification numbers below.

Van

ⓧJSAFDA32V00126001ⓧ	JS3DA32Vⓧ14126001	DA32V-126001
ⓧJSAFDA32V10126001ⓧ	JS3DA32VⓧY4126001	
ⓧJSAFDA32V14126001ⓧ	JS4DA32Vⓧ14126001	

Truck

ⓧJSAFDA32T00116001ⓧ	JS4DA32Tⓧ14116001	DA32T-116001
	JS4DA32TⓧY4116001	

It describes only different service information of the above applicable model as compared with GA413 SERVICE MANUAL.

Therefore, whenever servicing the above applicable model, consult this supplement first.

And for any section, item or description not found in this supplement, refer to the related manuals mentioned in the next page.

When replacing parts or servicing by disassembling, it is recommended to use SUZUKI genuine parts, tools and service materials (lubricant, sealants, etc.) as specified in each description.

All information, illustrations and specifications contained in this literature are based on the latest product information available at the time of publication approval, And used as the main subject of description is the vehicle of standard specifications among others. Therefore, note that illustrations may differ from the vehicle being actually serviced.

The right is reserved to make changes at any time without notice.

SUZUKI MOTOR CORPORATION
OVERSEAS SERVICE DEPARTMENT

RELATED MANUAL

MANUAL NAME	MANUAL NO.	APPLICABILITY
GA413 SERVICE MANUAL	99500-76A00-XXX	This manual is the base manual for this supplementary service manual.
GA413 SUPPLEMENTARY SERVICE MANUAL FOR 4WD MODEL	99501-76A00-XXX	4WD vehicle before the vehicle identification number mentioned in FOREWORD of this supplementary service manual.
GA413 WIRING DIAGRAM MANUAL	99512-76A10-015	Vehicle produced on and after October 1, 2000. Refer to the WIRING DIAGRAM MANUAL for details.
AIR CONDITIONING BASIC MANUAL	99520-02130-XXX	Vehicle equipped with air conditioning.

TABLE OF CONTENTS		SECTION
GENERAL INFORMATION	General Information	0A
	Maintenance and Lubrication	0B
HEATING AND AIR CONDITIONING	Heater and Ventilation	1A
	Air Conditioning	1B
STEERING, SUSPENSION, WHEELS AND TIRES	Steering, Suspension, Wheels and Tires	3
	Wheel Alignment	3A
	Manual Rack and Pinion	3B
	Electrical Power Steering (P/S) System	3B1
	Steering Wheel and Column	3C
	Front Suspension (2WD)	3D
	Front Suspension (4WD)	3D1
	Rear Suspension	3E
	Wheel and Tires	3F
DRIVE SHAFTS AND PROPELLER SHAFT	Front Drive Shaft (4WD)	4A
	Propeller Shaft (2WD)	4B
	Propeller Shaft (4WD)	4B1
BRAKE SYSTEM	Brake System	5
	Anti-lock Brake System (ABS)	5E
ENGINE	Engine General Information and Diagnosis	6
	Engine Mechanical	6A
	Engine Cooling	6B
	Engine Fuel	6C
	Engine and Emission Control System	6E
	Ignition System	6F
	Cranking System	6G
	Charging System	6H
	Exhaust System	6K
TRANSMISSION, CLUTCH AND DIFFERENTIAL	Manual Transmission (2WD)	7A
	Manual Transmission (4WD)	7A1
	Clutch	7C
	Differential (Front)	7E
	Differential (Rear)	7F
ELECTRICAL SYSTEM	Electrical System	8
	Wiring Diagram	8A
	Immobilizer Control System	8G
BODY SERVICE		9
RESTRAINT SYSTEM	Restraint System	10
	Air Bag System	10B

NOTE:

For the screen toned sections in the above table, refer to the same sections of the Service Manual mentioned in FOREWORD of this manual.

SECTION 0A

GENERAL INFORMATION

NOTE:

For the descriptions (items) not found in this section, refer to the Section 0A or 0A1 of the Service Manual mentioned in the FOREWORD of this manual.

CONTENTS

FASTENER INFORMATION	0A- 1
Metric Fasteners	0A- 1
Fastener Strength Identification	0A- 1
Standard Tightening Torque	0A- 2

FASTENER INFORMATION

METRIC FASTENERS

Most of the fasteners used for this vehicle are metric fasteners. When replacing any fasteners, it is most important that replacement fasteners be the correct diameter, thread pitch and strength.

FASTENER STRENGTH IDENTIFICATION

Most commonly used metric fastener strength property classes are 4T, 6.8, 7T, 8.8 and radial line with the class identification embossed on the head of each bolt. Some metric nuts will be marked with punch, 6 or 8 mark strength identification on the nut face. Figure shows the different strength markings.

When replacing metric fasteners, be careful to use bolts and nuts of the same strength or greater than the original fasteners (the same number marking or higher). It is likewise important to select replacement fasteners of the correct diameter and thread pitch. Correct replacement bolts and nuts are available through the parts division.

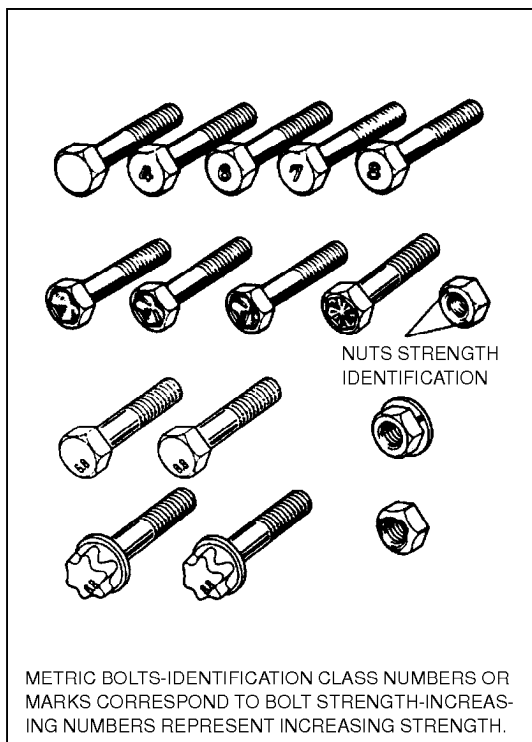







STANDARD TIGHTENING TORQUE

Each fastener should be tightened to the torque specified in each section of this manual. If no description or specification is provided, refer to the following tightening torque chart for the applicable torque for each fastener. When a fastener of greater strength than the original one is used, however, use the torque specified for the original fastener.

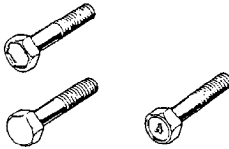
NOTE:

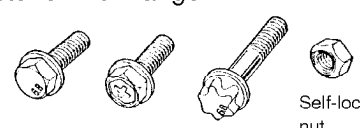
- For the flanged bolt, flanged nut and self-lock nut of 4T and 7T strength, add 10% to the tightening torque given in the chart below.
- The chart below is applicable only where the fastened parts are made of steel or light alloy.

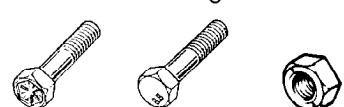
Tightening torque chart

Thread Diameter (Nominal Diameter) (mm)		4	5	6	8	10	12	14	16	18
		Strength								
An equivalent of 4T strength fastener 	N·m	1.5	3.0	5.5	13	29	45	65	105	160
	kg-m	0.15	0.30	0.55	1.3	2.9	4.5	6.5	10.5	16
	lb-ft	1.0	2.5	4.0	9.5	21.0	32.5	47.0	76.0	116.0
An equivalent of 6.8 strength fastener without flange 	N·m	2.4	4.7	8.4	20	42	80	125	193	280
	kg-m	0.24	0.47	0.84	2.0	4.2	8.0	12.5	19.3	28
	lb-ft	2.0	3.5	6.0	14.5	30.5	58.0	90.5	139.5	202.5
An equivalent of 6.8 strength fastener with flange 	N·m	2.4	4.9	8.8	21	44	84	133	203	298
	kg-m	0.24	0.49	0.88	2.1	4.4	8.4	13.3	20.3	29.8
	lb-ft	2.0	3.5	6.5	15.5	32.0	61.0	96.5	147.0	215.5
An equivalent of 7T strength fastener 	N·m	2.3	4.5	10	23	50	85	135	210	240
	kg-m	0.23	0.45	1.0	2.3	5.0	8.5	13.5	21	24
	lb-ft	2.0	3.5	7.5	17.0	36.5	61.5	98.0	152.0	174.0
An equivalent of 8.8 strength fastener without flange 	N·m	3.1	6.3	11	27	56	105	168	258	373
	kg-m	0.31	0.63	1.1	2.7	5.6	10.5	16.8	25.8	37.3
	lb-ft	2.5	4.5	8.0	19.5	40.5	76.0	121.5	187.0	270.0
An equivalent of 8.8 strength fastener with flange 	N·m	3.2	6.5	12	29	59	113	175	270	395
	kg-m	0.32	0.65	1.2	2.9	5.9	11.3	17.5	27	39.5
	lb-ft	2.5	5.0	9.0	21.0	43.0	82.0	126.5	195.5	286.0

SECTION 0B

0B

MAINTENANCE AND LUBRICATION

WARNING:
 For vehicles equipped with Supplemental Restraint (Air Bag) System:

- Service on and around the air bag system components or wiring must be performed only by an authorized SUZUKI dealer. Refer to AIR BAG SYSTEM COMPONENTS AND WIRING LOCATION VIEW of GENERAL DESCRIPTION in air bag system section in order to confirm whether you are performing service on or near the air bag system components or wiring. Please observe all WARNINGS and SERVICE PRECAUTIONS of ON-VEHICLE SERVICE in air bag system section before performing service on or around the air bag system components or wiring. Failure to follow WARNINGS could result in unintentional activation of the system or could render the system inoperative. Either of these two conditions may result in severe injury.
- Technical service work must be started at least 90 seconds after the ignition switch is turned to the LOCK position and negative cable is disconnected from the battery. Otherwise, the system may be activated by reserve energy in the Sensing and Diagnostic Module (SDM).

NOTE:
 For the descriptions (items) not found in this section, refer to the same section of the Service Manual mentioned in the FOREWORD of this manual.

CONTENTS

MAINTENANCE SCHEDULE	0B- 2
Maintenance schedule under normal driving conditions	0B- 2
Maintenance recommended under severe driving conditions	0B- 4
MAINTENANCE SERVICE	0B- 5
Engine	0B- 5
Emission control system	0B- 5
Chassis and body	0B- 6
RECOMMENDED FLUIDS AND LUBRICANTS	0B- 8

MAINTENANCE SCHEDULE

MAINTENANCE SCHEDULE UNDER NORMAL DRIVING CONDITIONS

Interval: This interval should be judged by odometer reading or months, whichever comes first.		This table includes services as scheduled up to 90,000 km (54,000 miles) mileage. Beyond 90,000 km (54,000 miles), carry out the same services at the same intervals respectively.						
		km (x 1,000)	15	30	45	60	75	90
		miles (x 1,000)	9	18	27	36	45	54
		Months	12	24	36	48	60	72
ENGINE								
1-1. Drive belt	V-belt	I	R	I	R	I	R	
	V-rib belt (Flat type)	-	-	I	-	-	R	
1-2. Camshaft timing belt		Replace every 100,000 km (60,000 miles).						
1-3. Valve lash (clearance)		-	I	-	I	-	I	
1-4. Engine oil and oil filter	Vehicle with HO2S (SG, SH, SJ grade oil)	R	R	R	R	R	R	
	Vehicle with HO2S (SE, SF grade oil), Vehicle without HO2S	Replace every 10,000 km (6,000 miles) or 8 months						
1-5. Engine coolant		-	-	R	-	-	R	
1-6. Exhaust system		-	I	-	I	-	I	
IGNITION SYSTEM								
2-1. Spark plugs	When unleaded fuel is used	Vehicle without HO2S	-	R	-	R	-	R
		Vehicle with HO2S	-	-	R	-	-	R
	When leaded fuel is used, refer to SEVERE DRIVING CONDITION schedule.							
FUEL SYSTEM								
3-1. Air cleaner filter element		I	I	R	I	I	R	
3-2. Fuel tank		-	-	I	-	-	I	
3-3. Fuel lines and connections		-	I	-	I	-	I	
3-4. Fuel filter		Replace every 105,000 km (63,000 miles).						
EMISSION CONTROL SYSTEM								
4-1. Crankcase ventilation hoses and connections		Vehicle without HO2S	-	I	-	I	-	I
4-2. PCV valve	Vehicle without HO2S		-	-	I	-	-	I
	Vehicle with HO2S		-	-	-	-	-	I
4-3. Fuel evaporative emission control system	Vehicle without HO2S		-	I	-	I	-	I
	Vehicle with HO2S		-	-	-	-	-	I

NOTES:

“R”: Replace or change

“I”: Inspect and correct, replace or lubricate if necessary

- For Item 2-1 SPARK PLUGS, replace every 50,000 km (30,000 miles) if the local law requires.
- For Item 1-2 Camshaft timing belt: This belt may be replaced every 90,000 km (54,000 miles) according to customer's maintenance convenience.

Interval: This interval should be judged by odometer reading or months, whichever comes first.	This table includes services as scheduled up to 90,000 km (54,000 miles) mileage. Beyond 90,000 km (54,000 miles), carry out the same services at the same intervals respectively.						
	km (x 1,000)	15	30	45	60	75	90
	miles (x 1,000)	9	18	27	36	45	54
	Months	12	24	36	48	60	72
CHASSIS AND BODY							
6- 1. Clutch	-	I	-	I	-	I	
6- 2. Brake discs and pads (front)	I	I	I	I	I	I	
Brake drums and shoes (rear)	-	I	-	I	-	I	
6- 3. Brake hoses and pipes	-	I	-	I	-	I	
6- 4. Brake fluid	-	R	-	R	-	R	
6- 5. Parking brake lever and cable	Inspect at first 15,000 km (9,000 miles) only						
6- 6. Tires	I	I	I	I	I	I	
6- 7. Wheel discs	I	I	I	I	I	I	
6- 8. Suspension system	-	I	-	I	-	I	
6- 9. Manual transmission oil (including transfer oil for 4WD) (I: 1st 15,000 km only)	I	-	R	-	-	R	
6-10. Differential oil (front for 4WD and rear) (R: 1st 15,000 km only)	R or I	-	I	-	I	-	
6-11. Steering system	-	I	-	I	-	I	
6-12. All hinges, latches and locks	-	I	-	I	-	I	
6-13. Propeller shaft(s) and drive shafts (4WD)	-	-	I	-	-	I	

NOTES:

“R”: *Replace or change*

“I”: *Inspect and correct, replace or lubricate if necessary*

MAINTENANCE RECOMMENDED UNDER SEVERE DRIVING CONDITIONS

If the vehicle is usually used under the conditions corresponding to any severe condition code given below, it is recommended that applicable maintenance operation be performed at the particular interval as given in the chart below.

SEVERE CONDITION CODE

A – Repeated short trips/Taxi use

B – Driving on rough and/or muddy roads

C – Driving on dusty roads

D – Driving in extremely cold weather and/or salted roads

E – Repeated short trips in extremely cold weather

F – Leaded fuel use

G – —

H – Trailer towing (if admitted)/Full load use

Severe Condition Code	Maintenance	Maintenance Operation	Maintenance Interval
— B C D — — — —	Drive belt (V-rib belt)	I	Every 15,000 km (9,000 miles) or 12 months
		R	Every 45,000 km (27,000 miles) or 36 months
A — C D E F — H	Engine oil and oil filter	R	Every 5,000 km (3,000 miles) or 4 months
A B C — E F — H	Spark plugs	R	Every 10,000 km (6,000 miles) or 8 months
— — C — — — — —	Air cleaner filter element *1	I	Every 2,500 km (1,500 miles)
		R	Every 30,000 km (18,000 miles) or 24 months
— B C D — — — H	Wheel bearings	I	Every 15,000 km (9,000 miles) or 12 months
— B — D E — — H	Propeller shaft(s)/Drive shafts (4WD)	I	Every 15,000 km (9,000 miles) or 12 months
— B — — E — — H	Manual transmission oil (including transfer oil for 4WD) and differential(s) oil	R	Every 30,000 km (18,000 miles) or 24 months
— B — — — — —	Suspension bolts and nuts	T	Every 15,000 km (9,000 miles) or 12 months

NOTES:

“I” : Inspect and correct, replace or lubricate if necessary

“R”: Replace or change

“T”: Tighten to the specified torque

***1** : Inspect or replace more frequently if necessary.

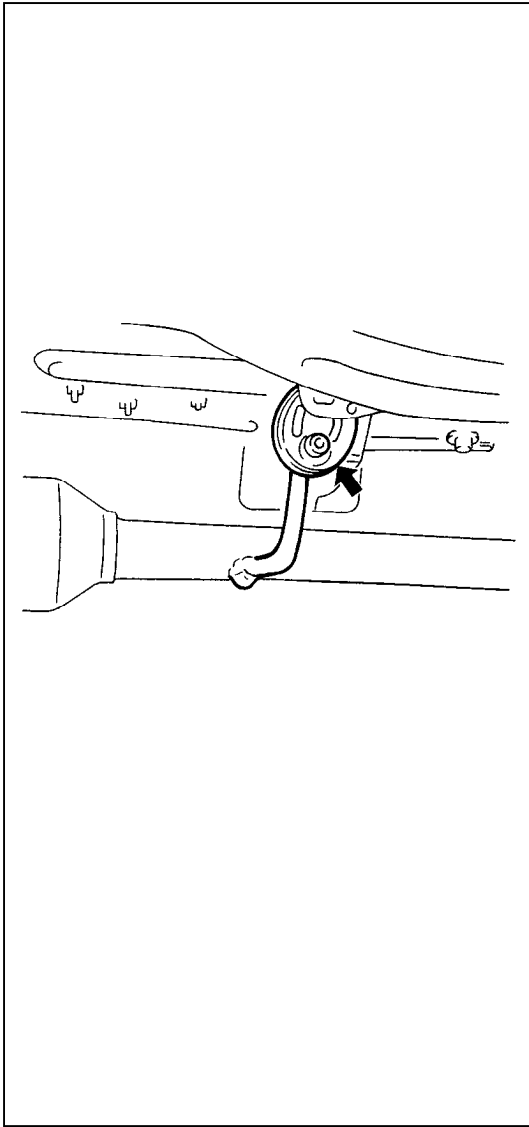

MAINTENANCE SERVICE

ENGINE

ITEM 1-6

Exhaust System Inspection

WARNING:

To avoid danger of being burned, do not touch exhaust system when it is still hot. Any service on exhaust system should be performed when it is cool.

When carrying out periodic maintenance, or the vehicle is raised for other service, check exhaust system as follows:

- Check rubber mountings for damage, deterioration, and out of position.
- Check exhaust system for leakage, loose connections, dents and damages.
If bolts or nuts are loose, tighten them to specification.
- Check nearby body areas for damaged, missing, or mispositioned parts, open seams, holes, loose connections or other defects which could permit exhaust fumes to seep into the vehicle.
- Make sure that exhaust system components have enough clearance from the underbody to avoid overheating and possible damage to the floor carpet.
- Any defects should be fixed at once.

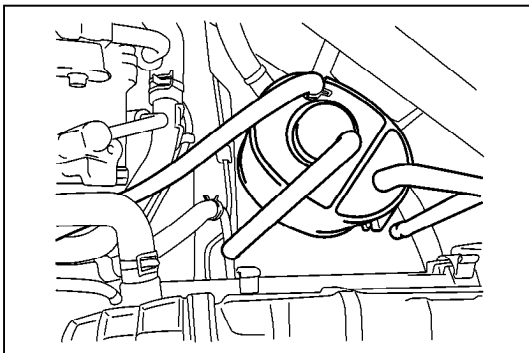

EMISSION CONTROL SYSTEM

ITEM 4-3

Fuel Evaporative Emission Control System Inspection

- 1) Visually inspect hoses for cracks, damage, or excessive bends. Inspect all clamps for damage and proper position.
- 2) Check EVAP canister for operation and clog referring to "EVAP EMISSION CONTROL SYSTEM" in SECTION 6E.

If a malfunction is found, repair or replace.

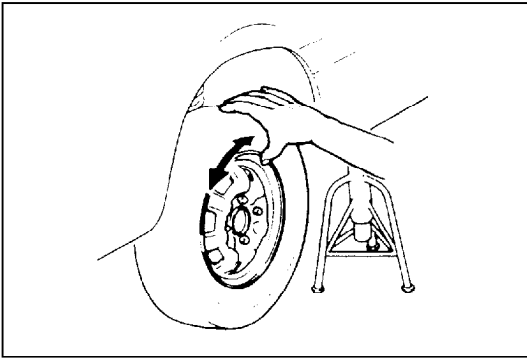

CHASSIS AND BODY

ITEM 6-7'

Wheel Bearing Inspection

- 1) Check front wheel bearing for wear, damage, abnormal noise or rattles. For details, refer to "WHEEL DISC, NUT AND BEARING CHECK" in Section 3D.
- 2) Check rear wheel bearing for wear, damage, abnormal noise or rattles. For details, refer to "WHEEL DISC, NUT AND BEARING CHECK" in Section 3E.

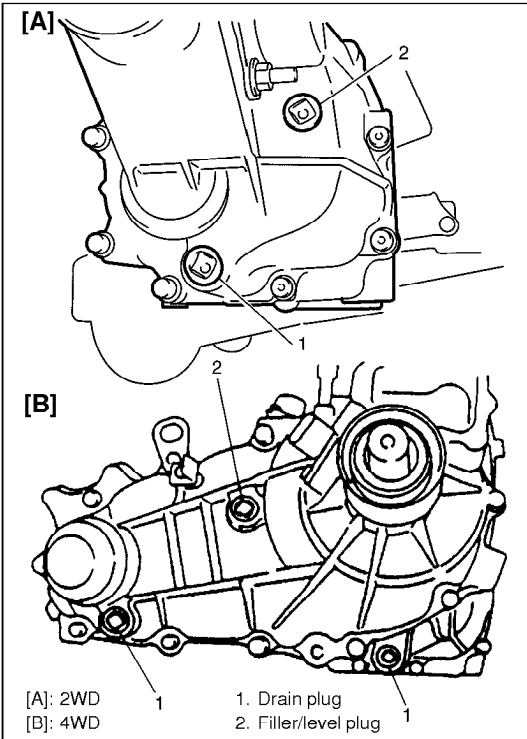

ITEM 6-9

Manual Transmission Oil (Including Transfer Oil for 4WD) Inspection

- 1) Inspect transmission case for evidence of oil leakage. Repair leaky point if any.
- 2) Make sure that vehicle is placed level for oil level check.
- 3) Remove level plug of transmission.
- 4) Check oil level.

Oil level can be checked roughly by means of level plug hole. That is, if oil flows out of level plug hole or if oil level is found up to hole when level plug is removed, oil is properly filled. If oil is found insufficient, pour specified amount of specified oil.
- 5) Tighten level plug to specified torque.

Refer to MAINTENANCE SERVICE in SECTION 7A or 7A1.

Change

Change transmission oil with new specified oil. Refer to MAINTENANCE SERVICE in SECTION 7A or 7A1.

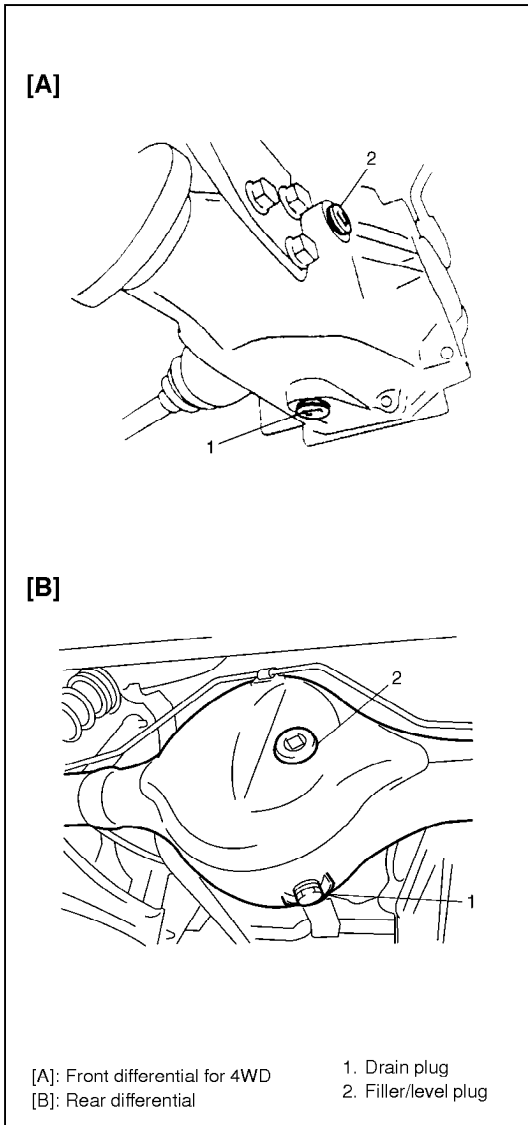

ITEM 6-10

Differential Oil (Front for 4WD and Rear)

Inspection

- 1) Check differential for evidence of oil leakage.
 Repair leaky point if any.
- 2) Make sure that vehicle is placed level for oil level check.
- 3) Remove level plug of differential and check oil level.
 Oil level can be checked roughly by means of level plug hole.
 That is, if oil flows out of level plug hole or if oil level is found up to hole when level plug is removed, oil is properly filled.
 If oil is found insufficient, pour specified amount of specified oil.

CAUTION:
Specified gear oil must be used for differential.

- 4) Tighten level plug to specified torque.
 Refer to OIL CHANGE in SECTION 7E and/or 7F.

Change

Change differential oil with new specified oil. Refer to OIL CHANGE in SECTION 7E and/or 7F.

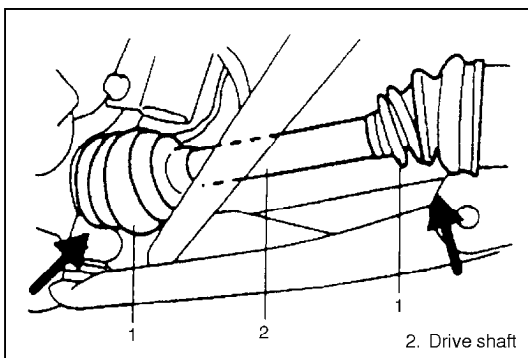

ITEM 6-13

Drive Shaft Boot Inspection (4WD)

Check drive shaft boot (wheel side and different side) (1) for leakage, detachment, tear or any other damage.
 Replace boot as necessary.

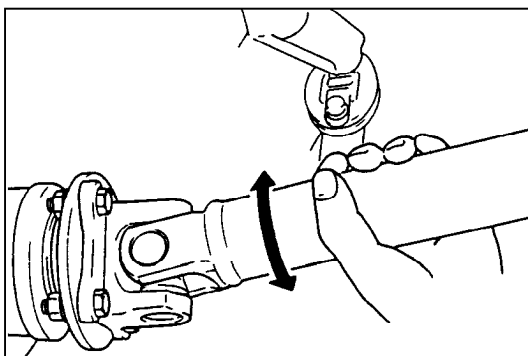

Propeller Shaft(s) Inspection

- 1) Check universal joint, constant velocity joint (4WD) and spline of propeller shaft for rattle and damage. If rattle or damage is found, replace defective part with a new one.
- 2) Check propeller shaft joint bolts for tightness, and retighten them as necessary.
 Refer to Section 4B or 4B1 for tightening torque.

RECOMMENDED FLUIDS AND LUBRICANTS

Engine oil	SE, SF, SG, SH or SJ grade oil (Refer to engine oil viscosity chart in ITEM 1-4 of MAINTENANCE SERVICE)
Engine coolant (Ethylene glycol base coolant)	Antifreeze/Anticorrosion coolant (Refer to ITEM 1-5 of MAINTENANCE SERVICE for detail.)
Brake fluid	DOT 3
Manual transmission oil	API GL-4 (Refer to MAINTENANCE SERVICE in SECTION 7A or 7A1 for detail)
Differential oil	Hypoid gear oil API GL-5 (Refer to OIL CHANGE in SECTION 7E front differential or 7F rear differential for detail.)
Clutch linkage pivot points	Water resistance chassis grease (SUZUKI SUPER GREASE A 99000-25010)
Door hinges	Engine oil or water resistance chassis grease
Hood latch assembly	
Key lock cylinder	Spray lubricant

SECTION 3D

FRONT SUSPENSION

NOTE:

- For the descriptions (items) not found in this section, refer to the same section of the Service Manual mentioned in the FOREWORD of this manual.
- All front suspension fasteners are an important attaching part in that it could affect the performance of vital parts and systems, and/or could result in major repair expense. They must be replaced with one of the same part number or with an equivalent part if replacement becomes necessary. Do not use a replacement part of lesser quality or substitute design. Torque values must be used as specified during reassembly to assure proper retention of this part.
- Never attempt to heat, quench or straighten any front suspension part. Replace it with a new part or damage to the part may result.

3D

CONTENTS

GENERAL DESCRIPTION	3D- 2
ON-VEHICLE SERVICE	3D- 3
Strut Damper Assembly	3D- 3

GENERAL DESCRIPTION

The front suspension is the strut type independent suspension. The upper end of a strut is anchored to the vehicle body by a strut support. The strut and strut support are isolated by a strut rubber support. A strut bearing is also installed a little lower to the strut rubber support.

The lower end of the strut is connected to the upper end of a steering knuckle and lower end of knuckle is attached to the stud of a ball joint which is incorporated in a unit with a suspension control arm. And connected to this steering knuckle is the tie-rod end.

Thus, movement of the steering wheel is transmitted to the tie-rod end and then to the knuckle, eventually causing the wheel and tire to move. In this operation, with the movement of the knuckle, the strut also rotates by means of the strut bearing and lower ball joint.

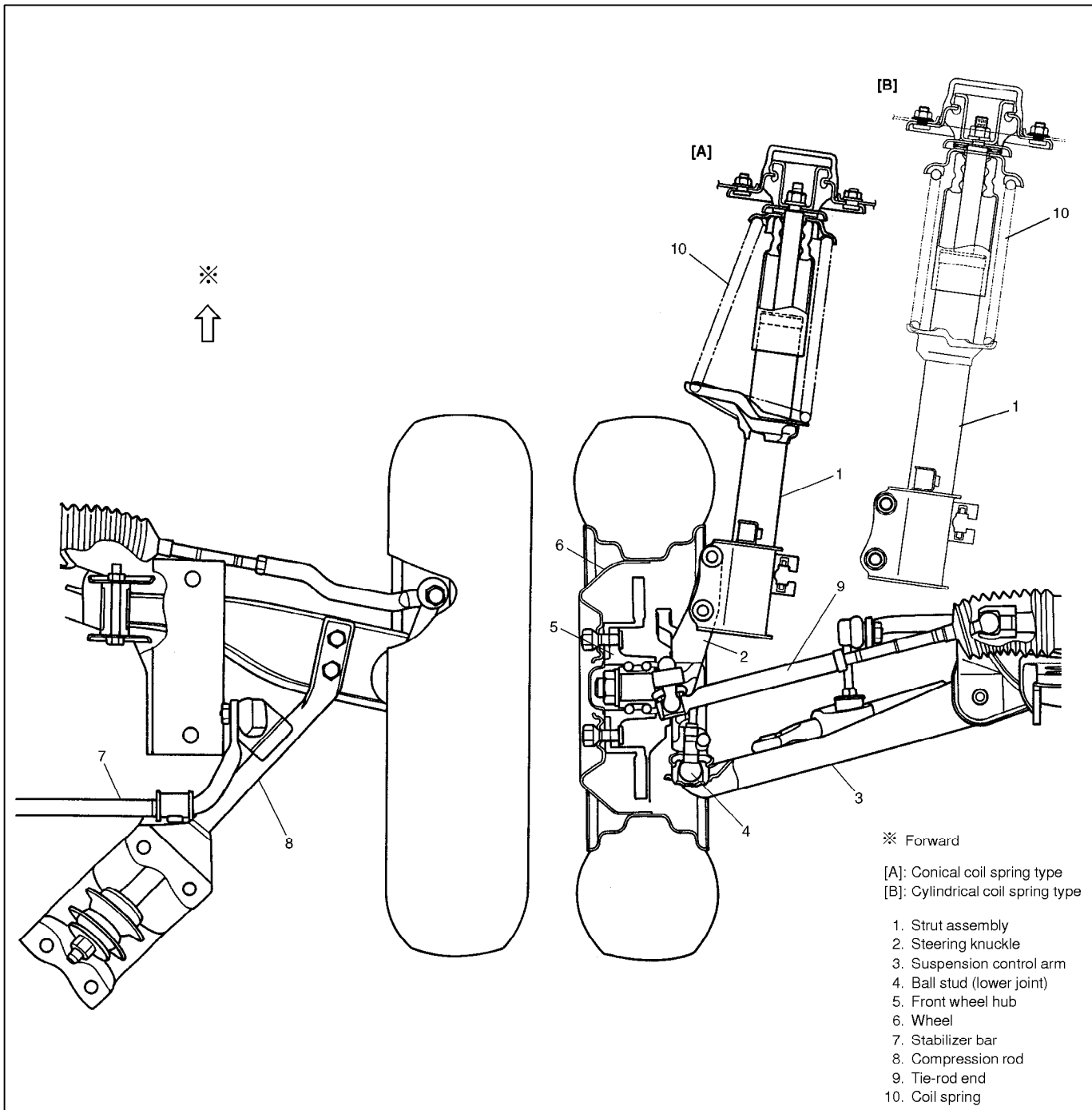

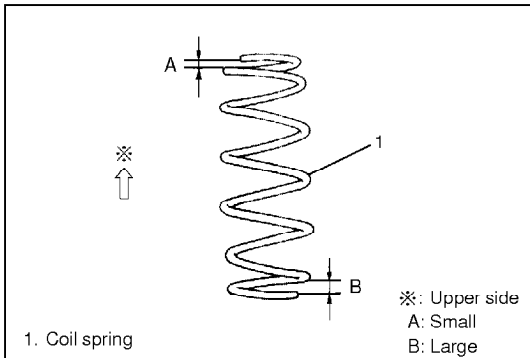

ON-VEHICLE SERVICE

STRUT DAMPER ASSEMBLY

ASSEMBLY

For the details, refer to the same item of the same section in service manual mentioned in FOREWORD of this manual noting the following points.

- For cylindrical coil spring type, make sure that coil spring direction as shown.
- On bearing seat, install rebound stopper, strut support and rubber support in this sequence. Refer to the figure for installing directions. Tighten strut nut to specified torque and then apply water-proof coating (paint or lacquer) all around nut and strut rod screw part.

NOTE:

As shown at the left, have sections "A" and "B" of strut support rubber caught by strut support securely.

Tightening Torque

(a): 50 N·m (5.0 kg·m, 36.5 lb·ft)

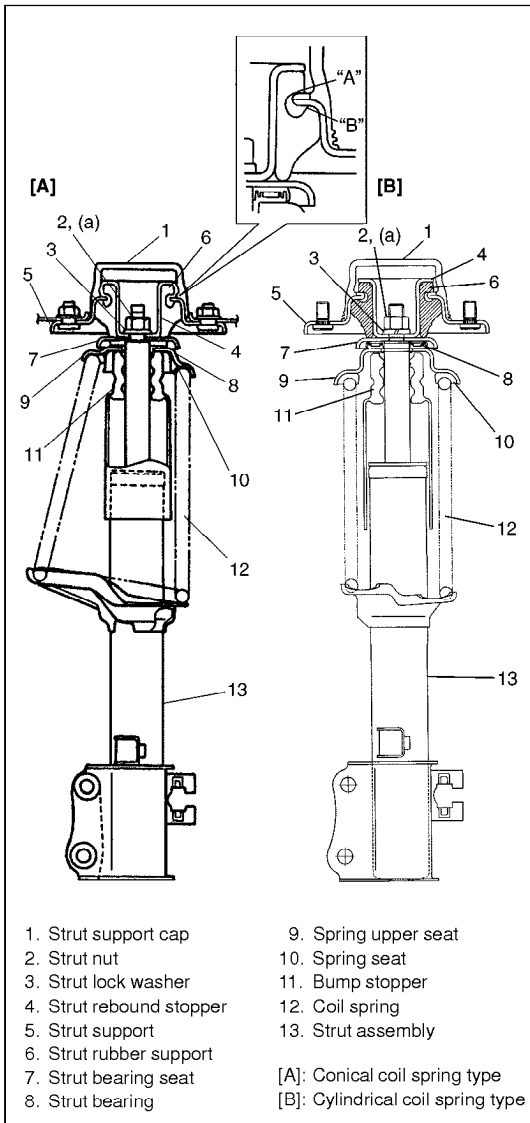

SECTION 3E

REAR SUSPENSION

NOTE:

- For the descriptions (items) not found in this section, refer to the same section of the Service Manual mentioned in the FOREWORD of this manual.
- All suspension fasteners are an important attaching part in that it could affect the performance of vital parts and systems, and/or could result in major repair expense. They must be replaced with one of the same part number or with an equivalent part if replacement becomes necessary. Do not use a replacement part of lesser quality or substitute design. Torque values must be used as specified during reassembly to assure proper retention of this part.
- Never attempt to heat, quench or straighten any suspension part. Replace it with a new part, or damage to the part may result.

3E

CONTENTS

GENERAL DESCRIPTION 3E- 1

GENERAL DESCRIPTION

Rear suspension is a type which consists of coil springs, rear axle, shock absorbers, lateral rod and trailing arms. The lateral rod is installed to the body and axle by using bushes so as to prevent axle movement in the lateral direction.

The trailing arms which are connected with the axle are installed to the body by using a bush so that axle moves up and down with the bush as its supporting point.

The shock absorber is installed between the body and axle to absorb up-and-down movement of the vehicle body.

[A]

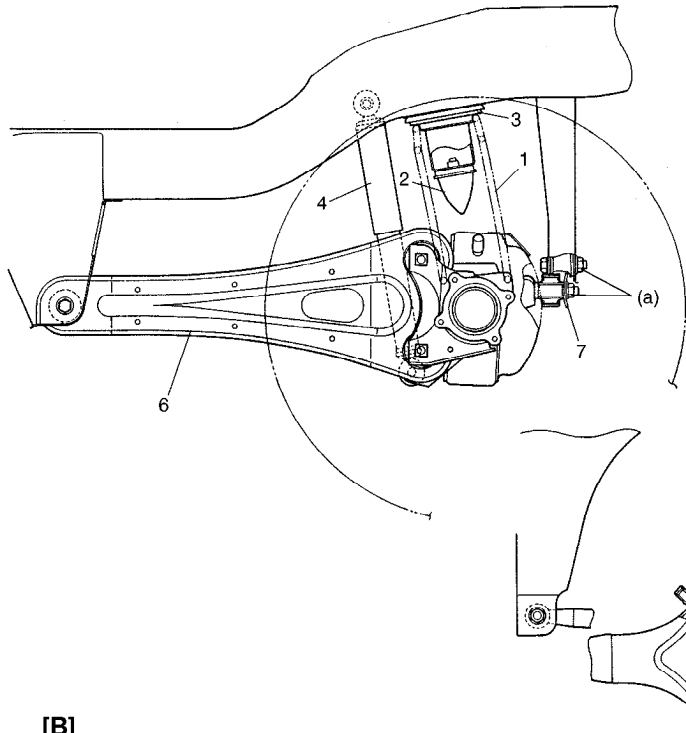

[B]

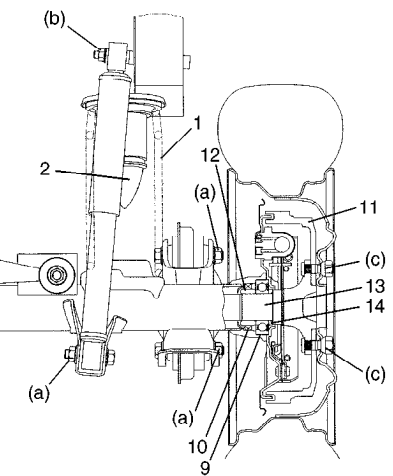
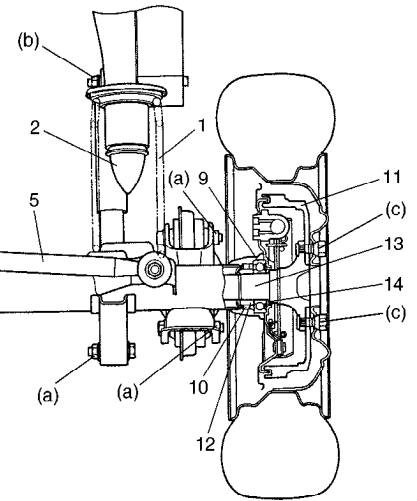
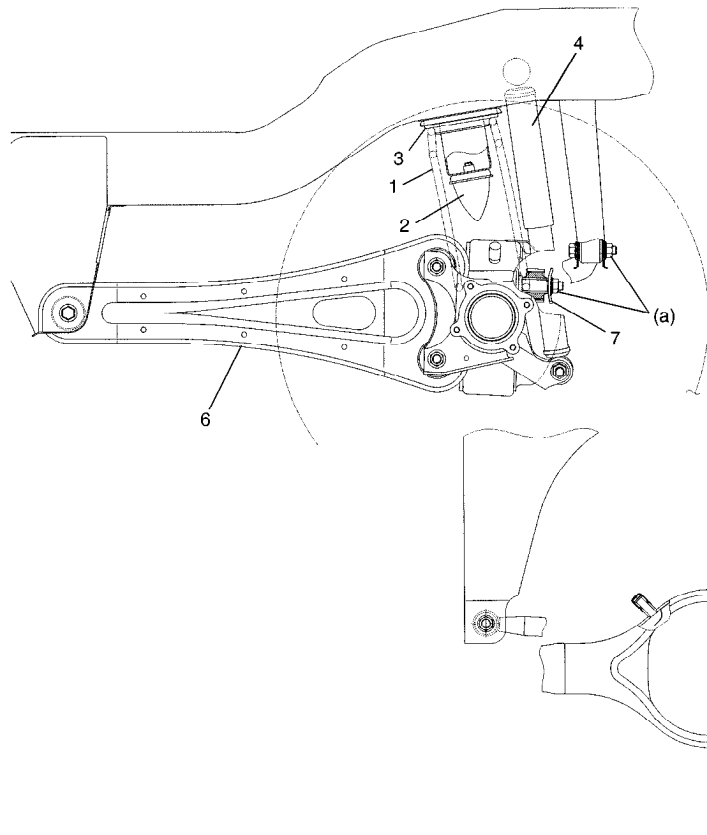

- 1. Rear coil spring
- 2. Rear bump stopper
- 3. Rear spring upper seat
- 4. Rear shock absorber
- 5. Lateral rod
- 6. Trailing arm
- 7. Lateral rod outer washer

- 8. Rear axle
- 9. Bearing
- 10. Rear shaft oil seal
- 11. Brake drum
- 12. Bearing retainer ring
- 13. Rear axle shaft
- 14. Wheel bearing spacer

[A]: Type A
[B]: Type B

Tightening Torque
(a): 80 N·m (8.0 kg-m, 58.0 lb-ft)
(b): 55 N·m (5.5 kg-m, 40.0 lb-ft)
(c): 85 N·m (8.5 kg-m, 61.5 lb-ft)

SECTION 5

BRAKES

WARNING:

For vehicles equipped with Supplemental Restraint (Air Bag) System:

- Service on and around the air bag system components or wiring must be performed only by an authorized SUZUKI dealer. Refer to AIR BAG SYSTEM COMPONENTS AND WIRING LOCATION VIEW of GENERAL DESCRIPTION in air bag system section in order to confirm whether you are performing service on or near the air bag system components or wiring. Please observe all WARNINGS and SERVICE PRECAUTIONS of ON-VEHICLE SERVICE in air bag system section before performing service on or around the air bag system components or wiring. Failure to follow WARNINGS could result in unintentional activation of the system or could render the system inoperative. Either of these two conditions may result in severe injury.
- Technical service work must be started at least 90 seconds after the ignition switch is turned to the LOCK position and negative cable is disconnected from the battery. Otherwise, the system may be activated by reserve energy in the Sensing and Diagnostic Module (SDM).

NOTE:

- For the descriptions (items) not found in this section, refer to the same section of the Service Manual mentioned in the FOREWORD of this manual.
- All brake fasteners are important attaching parts in that they could affect the performance of vital parts and systems, and/or could result in major repair expense. They must be replaced with one of same part number or with an equivalent part if replacement becomes necessary. Do not use a replacement part of lesser quality or substitute design. Torque values must be used as specified during reassembly to assure proper retention of all parts. There is to be no welding as it may result in extensive damage and weakening of the metal.

CONTENTS

GENERAL DESCRIPTION	5- 2	ON-VEHICLE SERVICE	5- 3
CHECK AND ADJUSTMENT	5- 2	Front Brake Hose/Pipe	5- 3
Stop Light Switch Adjustment	5- 2	Brake Pad	5- 4
		Brake Stop Lamp	5- 4

GENERAL DESCRIPTION

When the foot brake pedal is depressed, hydraulic pressure is developed in the master cylinder to actuate pistons (two in front and four in rear).

The master cylinder is a tandem master cylinder. The brake pipes are connected to the master cylinder and they make two independent circuits. One connects front brakes (right and left) and the other connects rear brakes (right and left).

The load sensing proportioning valve (LSPV) is included in these circuits between the master cylinder and rear wheels. In brake system of this model, the disc brake type is used of the front wheel brake and a drum brake type (leading/trailing shoes) for the rear wheel brake.

The parking brake system is mechanical. It applies brake force to only rear wheels by means of the cable and mechanical linkage system. The same brake shoes are used for both parking and foot brakes.

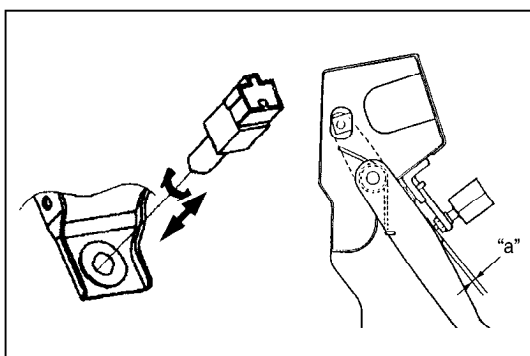
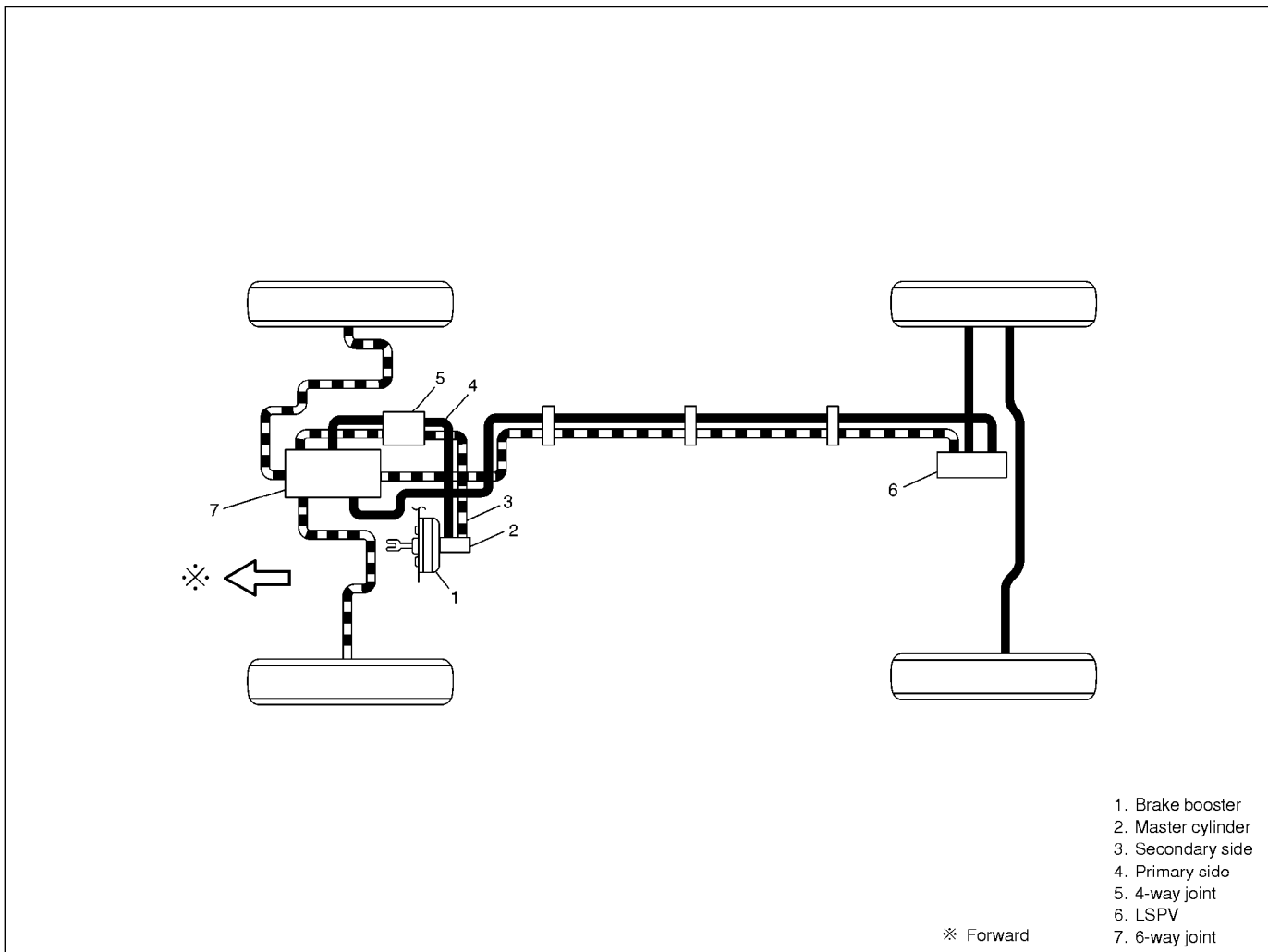

CHECK AND ADJUSTMENT STOP LIGHT SWITCH ADJUSTMENT

Adjustment should be made as follows when installing switch. Pull up brake pedal toward you and while holding it there, adjust switch position so that clearance between end of switch and brake pedal is specified.

Clearance "a": 0.5 – 1.0 mm (0.02 – 0.04 in.)

ON-VEHICLE SERVICE

FRONT BRAKE HOSE/PIPE REMOVAL AND INSTALLATION

- 1) Raise and support vehicle properly. Remove wheel.

This operation is not necessary when removing pipes connecting master cylinder and P valve.

- 2) Clean dirt and foreign material from both flexible hose end and pipe end fittings. Remove brake flexible hose or pipe.

- 3) Reverse brake flexible hose installation procedure.

For installation, make sure that steering wheel is in straightforward position and flexible hose has not twist or kink. Check to make sure that flexible hose doesn't contact any part of suspension, both in extreme right and extreme left turn conditions. If it does at any point, remove and correct. Fill and maintain brake fluid level in reservoir. Bleed brake system.

- 4) Perform brake test and check installed part for fluid leakage.

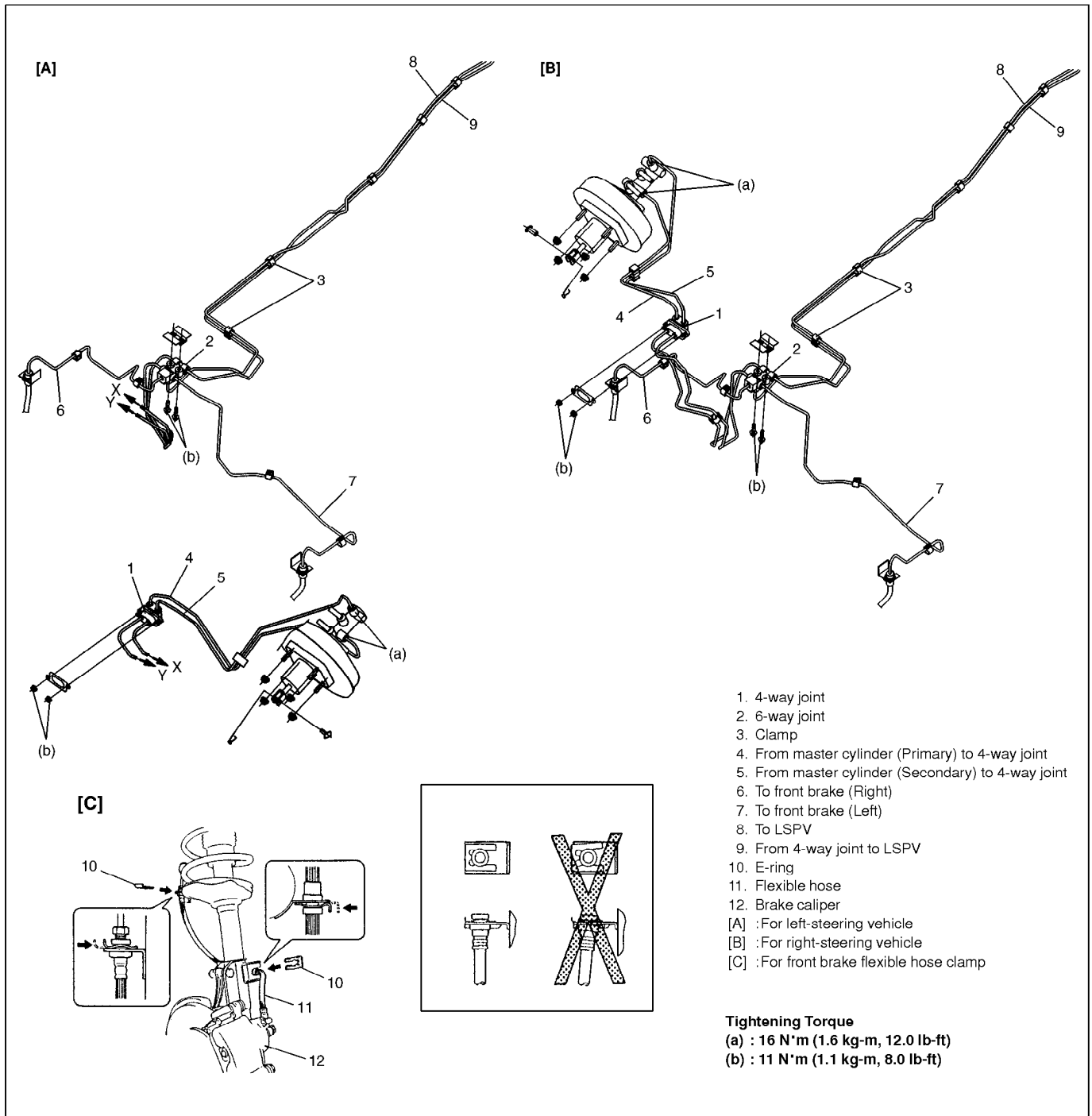

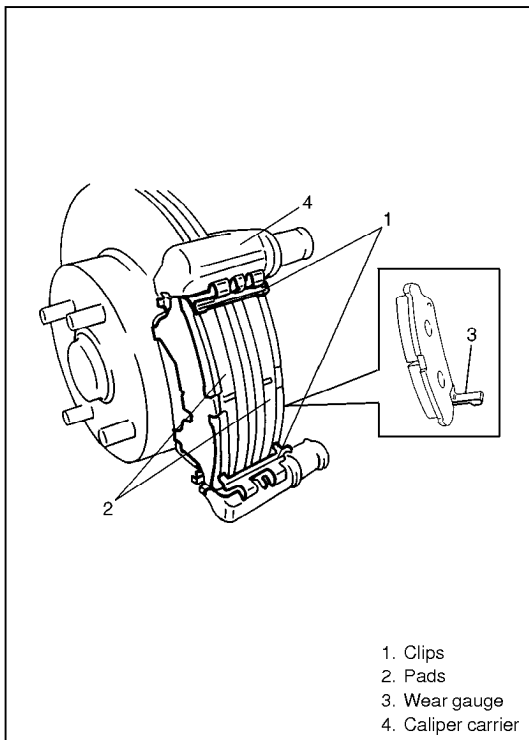

BRAKE PAD

INSTALLATION

For the details, refer to the same item of the same section in service manual mentioned in FOREWORD of this manual noting the following.

NOTE:

See NOTE at the beginning of this section.

Install shims to pads, then pad clips and pads to caliper carrier.

NOTE:

- In case of using a pad set including two brake pads with wear gauge, install the pads with wear gauge to body center side of caliper carrier, right and left respectively.
- In case of using a pad set including one brake pad with wear gauge, install the pad with wear gauge to body center side of right caliper carrier.

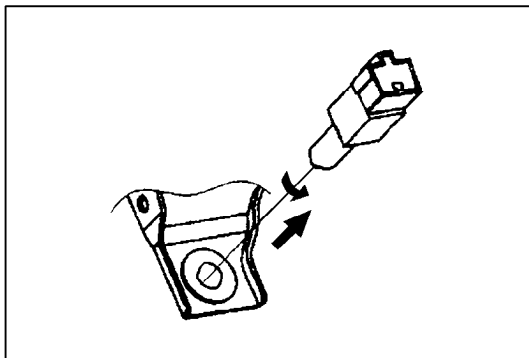

BRAKE STOP LAMP

REMOVAL

- 1) Disconnect negative cable at battery.
- 2) Disconnect stop lamp switch connector.
- 3) Remove stop lamp switch from pedal bracket by turning it counterclockwise and pulling.

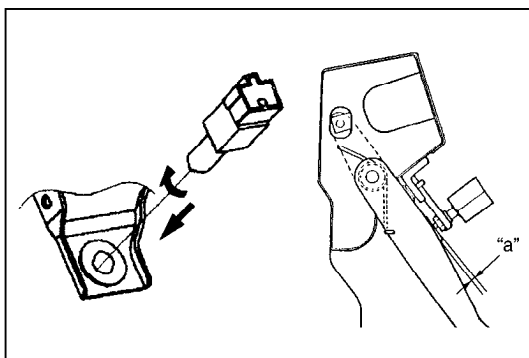

INSTALLATION

- 1) Adjust stop lamp switch position to clearance "a" between end of the switch and brake pedal, and turn the switch clockwise to fasten it.
For clearance "a" specifications, refer to STOP LIGHT SWITCH ADJUSTMENT in this section.
- 2) Connect stop lamp switch connector.
- 3) Connect negative cable at battery.

SECTION 6

ENGINE GENERAL INFORMATION AND DIAGNOSIS

WARNING:

For vehicles equipped with Supplemental Restraint (Air Bag) System:

- Service on and around the air bag system components or wiring must be performed only by an authorized SUZUKI dealer. Refer to “Air Bag System Components and Wiring Location View” under “General Description” in air bag system section in order to confirm whether you are performing service on or near the air bag system components or wiring. Please observe all WARNINGS and “Service Precautions” under “On-Vehicle Service” in air bag system section before performing service on or around the air bag system components or wiring. Failure to follow WARNINGS could result in unintentional activation of the system or could render the system inoperative. Either of these two conditions may result in severe injury.
- Technical service work must be started at least 90 seconds after the ignition switch is turned to the “LOCK” position and the negative cable is disconnected from the battery. Otherwise, the system may be activated by reserve energy in the Sensing and Diagnostic Module (SDM).

NOTE:

Whether the following systems (parts) are used in the particular vehicle or not depends on vehicle specifications. Be sure to bear this in mind when performing service work.

- EGR valve
- Heated oxygen sensor(s) or CO adjusting resistor
- Three-way catalytic converter (TWC) and warm up three-way catalytic converter (WU-TWC)

6

GENERAL INFORMATION AND ENGINE DIAGNOSIS	6-1
ENGINE MECHANICAL	6A-1
ENGINE COOLING	6B-1
ENGINE FUEL	6C-1
ENGINE AND EMISSION CONTROL SYSTEM	6E-1
IGNITION SYSTEM	6F-1
CRANKING SYSTEM	6G-1
CHARGING SYSTEM	6H-1
EXHAUST SYSTEM	6K-1

CONTENTS

GENERAL INFORMATION	6- 3	Fuel Pressure Relief Procedure	6- 5
Statement on Cleanliness and Care	6- 3	Fuel Leakage Check Procedure	6- 5
General Information on Engine Service	6- 3	ENGINE DIAGNOSIS	6- 6
Precaution on Fuel System Service	6- 4	General Description	6- 6

On-Board Diagnostic System (Vehicle with EGR valve)	6- 6	DTC P0136 HO2S Circuit Malfunction (Sensor-2)	6-57
On-Board Diagnostic System (Vehicle without EGR valve)	6- 9	DTC P0141 HO2S Heater Circuit Malfunction (Sensor-2)	6-60
Precaution in Diagnosing Trouble	6-10	DTC P0148 Fuel Pressure Control Valve Circuit Malfunction	6-62
Engine Diagnostic Flow Table	6-12	DTC P0171 Fuel System Too Lean	6-63
Customer Problem Inspection Form	6-14	DTC P0172 Fuel System Too Rich	6-63
Malfunction Indicator Lamp check	6-15	DTC P0300 Random Misfire Detected	6-67
Diagnostic Trouble Code Check	6-15	DTC P0301 Cylinder 1 Misfire Detected	6-67
Diagnostic Trouble Code Clearance	6-16	DTC P0302 Cylinder 2 Misfire Detected	6-67
Diagnostic Trouble Code Table	6-17	DTC P0303 Cylinder 3 Misfire Detected	6-67
Fail-safe Table	6-20	DTC P0304 Cylinder 4 Misfire Detected	6-67
Visual Inspection	6-21	DTC P0335 (No.23) CKP Sensor Circuit Malfunction	6-71
Engine Basic Inspection	6-22	DTC P0340 (No.15) CMP Sensor Circuit Malfunction	6-73
Engine Diagnosis Table	6-24	DTC P0400 EGR Flow Malfunction	6-75
Scan Tool Data	6-30	DTC P0420 Catalyst System Efficiency Below Threshold	6-78
Scan Tool Data Definitions	6-32	DTC P0443 Purge Control Valve Circuit Malfunction	6-81
Inspection of ECM and Its Circuits	6-34	DTC P0480 Radiator Fan Control System Malfunction	6-82
Resistance Check	6-34	DTC P0500 (NO.16) Vehicle Speed Sensor Malfunction	6-84
Component Location	6-35	DTC P0505 Idle Control System Malfunction	6-86
Table A-1 MIL Circuit Check (MIL does not come on)	6-36	DTC P1450 Barometric Pressure Sensor Low/High Input	6-88
Table A-2 MIL Circuit Check (MIL remains ON)	6-37	DTC P1451 Barometric Pressure Sensor Performance Problem	6-88
Table A-3 MIL Circuit Check (MIL flashes)	6-37	DTC P1500 Engine Starter Signal Circuit Malfunction	6-90
Table A-4 MIL Circuit Check (MIL does not flash)	6-38	DTC P1510 ECM Back-up Power Supply Malfunction	6-91
Table A-5 ECM Power and Ground Circuit Check	6-39	Table B-1 Fuel Injector Circuit Check	6-92
DTC P0105 (No.11) MAP Circuit Malfunction	6-41	Table B-2 Fuel Pump and Its Circuit Check ..	6-93
DTC P0110 (No.18) IAT Circuit Malfunction ..	6-43	Table B-3 Fuel Pressure Check	6-95
DTC P0115 (No.19) ECT Circuit Malfunction .	6-45	Table B-4 Idle Air Control System Check	6-96
DTC P0120 (No.13) Throttle Position Circuit Malfunction	6-47	Table B-5 A/C Signal Circuits Check	6-98
DTC P0121 Throttle Position Circuit Range/ Performance Problem	6-49	Table B-6 Electric Load Signal Circuit Check .	6-99
DTC P0130 HO2S Circuit Malfunction (Sensor-1)	6-51	Table B-7 Radiator Fan Control System Check	6-100
DTC P0133 HO2S Circuit Slow Response (Sensor-1)	6-53	SPECIAL TOOLS	6-102
DTC P0134 (No.14) HO2S Circuit No Activity Detected (Sensor-1)	6-54		
DTC P0135 HO2S Heater Circuit Malfunction (Sensor-1)	6-55		

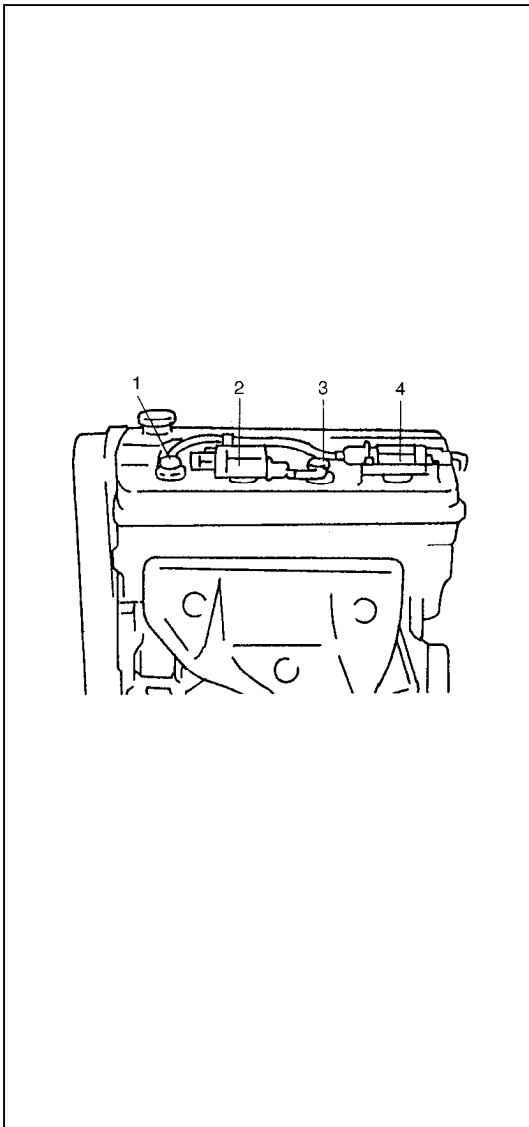

GENERAL INFORMATION

STATEMENT ON CLEANLINESS AND CARE

An automobile engine is a combination of many machined, honed, polished and lapped surfaces with tolerances that are measured in the thousands of an millimeter (ten thousands of an inch).

Accordingly, when any internal engine parts are serviced, care and cleanliness are important.

Throughout this section, it should be understood that proper cleaning and protection of machined surfaces and friction areas is part of the repair procedure. This is considered standard shop practice even if not specifically stated.

- A liberal coating of engine oil should be applied to friction areas during assembly to protect and lubricate the surfaces on initial operation.

- Whenever valve train components, pistons, piston rings, connecting rods, rod bearings, and crankshaft journal bearings are removed for service, they should be retained in order.

At the time of installation, they should be installed in the same locations and with the same mating surfaces as when removed.

- Battery cables should be disconnected before any major work is performed on the engine.

Failure to disconnect cables may result in damage to wire harness or other electrical parts.

- Throughout this manual, the four cylinders of the engine are identified by numbers; No.1 (1), No.2 (2), No.3 (3) and No.4 (4) counted from crankshaft pulley side to flywheel side.

GENERAL INFORMATION ON ENGINE SERVICE

THE FOLLOWING INFORMATION ON ENGINE SERVICE SHOULD BE NOTED CAREFULLY, AS IT IS IMPORTANT IN PREVENTING DAMAGE, AND IN CONTRIBUTING TO RELIABLE ENGINE PERFORMANCE.

- When raising or supporting engine for any reason, do not use a jack under oil pan. Due to small clearance between oil pan and oil pump strainer, jacking against oil pan may cause it to be bent against strainer resulting in damaged oil pick-up unit.

- It should be kept in mind, while working on engine, that 12-volt electrical system is capable of violent and damaging short circuits.

When performing any work where electrical terminals can be grounded, ground cable of the battery should be disconnected at battery.

- Any time the air cleaner, throttle body or intake manifold is removed, the intake opening should be covered. This will protect against accidental entrance of foreign material which could follow intake passage into cylinder and cause extensive damage when engine is started.

HOSE CONNECTION

With short pipe, fit hose as far as it reaches pipe joint as shown.

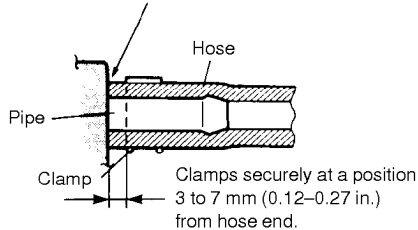

With following type pipe, fit hose as far as its peripheral projection as shown.

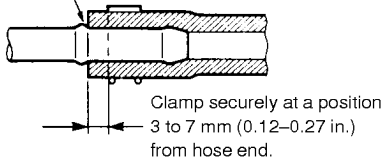

With bent pipe, fit hose as its bent part as shown or till pipe is about 20 to 30 mm (0.79-1.18 in.) into the hose.

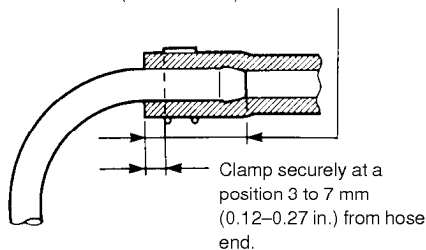

With straight pipe, fit hose till pipe is, about 20 to 30 mm (0.79-1.18 in.) into the hose.

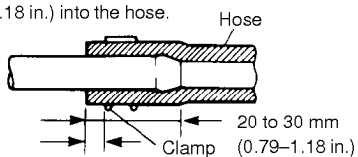

Clamp securely at a position 3 to 7 mm (0.12-0.27 in.) from hose end.

PRECAUTION ON FUEL SYSTEM SERVICE

- Work must be done with no smoking, in a well-ventilated area and away from any open flames.
- As fuel feed line (between fuel pump and fuel delivery pipe) is still under high fuel pressure even after engine was stopped, loosening or disconnecting fuel feed line directly may cause dangerous spout of fuel to occur where loosened or disconnected. Before loosening or disconnecting fuel feed line, make sure to release fuel pressure according to "FUEL PRESSURE RELIEF PROCEDURE". A small amount of fuel may be released after the fuel line is disconnected. In order to reduce the chance of personal injury, cover the fitting to be disconnected with a shop cloth. Put that cloth in an approved container when disconnection is completed.
- Never run engine with fuel pump relay disconnected when engine and exhaust system are hot.
- Fuel or fuel vapor hose connection varies with each type of pipe. When reconnecting fuel or fuel vapor hose, be sure to connect and clamp each hose correctly referring to left figure Hose Connection. After connecting, make sure that it has no twist or kink.
- When installing injector or fuel delivery pipe, lubricate its O-ring with spindle oil or gasoline.
- When connecting fuel pipe flare nut, first tighten flare nut by hand and then tighten it to specified torque.

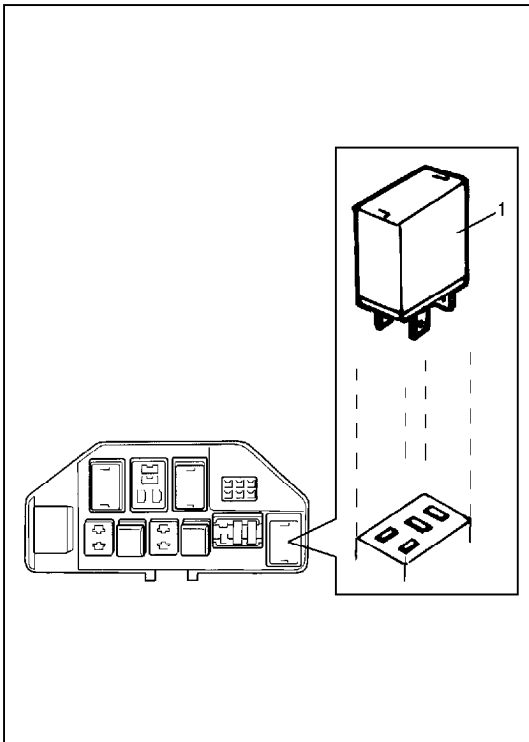

FUEL PRESSURE RELIEF PROCEDURE

CAUTION:

This work must not be done when engine is hot. If done so, it may cause adverse effect to catalyst.

After making sure that engine is cold, release fuel pressure as follows.

- 1) Place transmission gear shift lever in "Neutral" (Shift selector lever to "P" range for A/T model), set parking brake, and block drive wheels.
- 2) Remove relay box cover.
- 3) Disconnect fuel pump relay (1) from its connector.
- 4) Remove fuel filler cap to release fuel vapor pressure in fuel tank and then reinstall it.
- 5) Start engine and run it till it stops for lack of fuel. Repeat cranking engine 2-3 times for about 3 seconds each time to dissipate fuel pressure in lines. Fuel connections are now safe for servicing.
- 6) Upon completion of servicing, connect fuel pump relay (1) to its connector.

FUEL LEAKAGE CHECK PROCEDURE

After performing any service on fuel system, check to make sure that there are no fuel leakages as follows.

- 1) Turn ON ignition switch for 3 seconds (to operate fuel pump) and then turn it OFF.
Repeat this (ON and OFF) 3 or 4 times and apply fuel pressure to fuel line. (till fuel pressure is felt by hand placed on fuel feed hose.)
- 2) In this state, check to see that there are no fuel leakages from any part of fuel system.

ENGINE DIAGNOSIS

GENERAL DESCRIPTION

This vehicle is equipped with an engine and emission control system which are under control of ECM.

The engine and emission control system in this vehicle are controlled by ECM. ECM has an On-Board Diagnostic system which detects a malfunction in this system and abnormality of those parts that influence the engine exhaust emission. When diagnosing engine troubles, be sure to have full understanding of the outline of "On-Board Diagnostic System" and each item in "Precaution in Diagnosing Trouble" and execute diagnosis according to "ENGINE DIAGNOSTIC FLOW TABLE".

There is a close relationship between the engine mechanical, engine cooling system, ignition system, exhaust system, etc. and the engine and emission control system in their structure and operation. In case of an engine trouble, even when the malfunction indicator lamp (MIL) doesn't turn ON, it should be diagnosed according to this flow table.

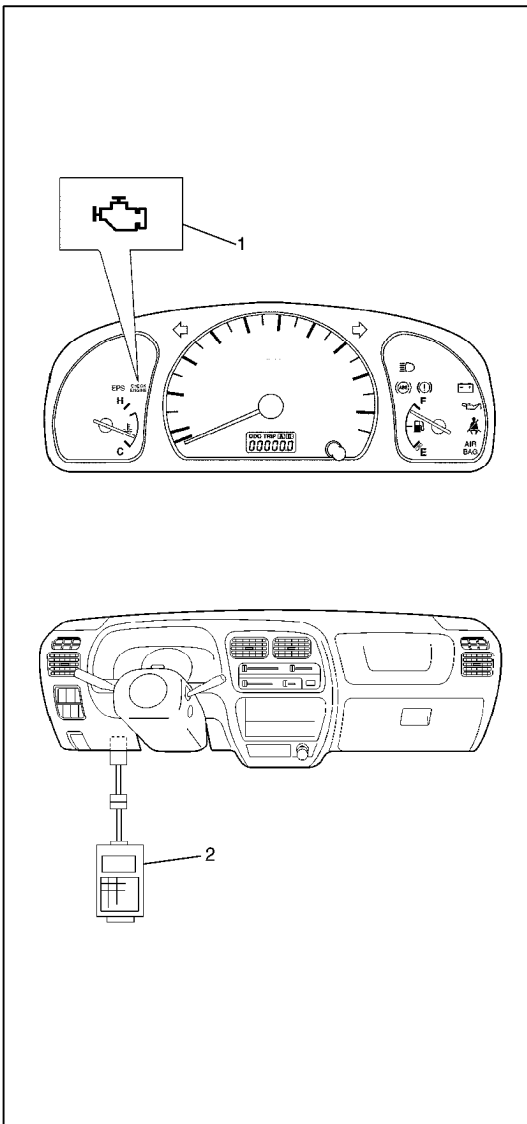

ON-BOARD DIAGNOSTIC SYSTEM (VEHICLE WITH EGR VALVE)

ECM in this vehicle has following functions.

- When the ignition switch is turned ON with the engine at a stop, malfunction indicator lamp (MIL) (1) turns ON to check the bulb of the malfunction indicator lamp (1).
- When ECM detects a malfunction which gives an adverse effect to vehicle emission while the engine is running, it makes the malfunction indicator lamp (1) in the meter cluster of the instrument panel turn ON or flash (flashing only when detecting a misfire which can cause damage to the catalyst) and stores the malfunction area in its memory.
(If it detects that continuously 3 driving cycles are normal after detecting a malfunction, however, it makes MIL (1) turn OFF although DTC stored in its memory will remain.)
- As a condition for detecting a malfunction in some areas in the system being monitored by ECM and turning ON the malfunction indicator lamp (1) due to that malfunction, 2 driving cycle detection logic is adopted to prevent erroneous detection.
- When a malfunction is detected, engine and driving conditions then are stored in ECM memory as freeze frame data. (For the details, refer to description on Freeze frame data.)
- It is possible to communicate by using not only SUZUKI scan tool (Tech-1) (2) but also generic scan tool. (Diagnostic information can be accessed by using a scan tool.)

Warm-up Cycle

A warm-up cycle means sufficient vehicle operation such that the coolant temperature has risen by at least 22°C (40°F) from engine starting and reaches a minimum temperature of 70°C (160°F).

Driving Cycle

A “Driving Cycle” consists of engine startup, driving mode where a malfunction would be detected if present, and engine shutoff.

2 Driving Cycles Detection Logic

The malfunction detected in the first driving cycle is stored in ECM memory (in the form of pending DTC and freeze frame data) but the malfunction indicator lamp does not light at this time. It lights up at the second detection of same malfunction also in the next driving cycle.

Pending DTC

Pending DTC means a DTC detected and stored temporarily at 1 driving cycle of the DTC which is detected in the 2 driving cycle detection logic.

An Example of Freeze Frame Data

- 1. Trouble Code P0102 (1st) ←
- 2. Engine Speed 782 RPM
- 3. Eng Cool Tmp. 80°C
- 4. Vehicle Spd. 0 km/h
- 5. MAP Sensor 39 kPa
- 6. St. Term FT1 - 0.8% Lean
- 7. Lg. Term FT1 - 1.6% Lean
- 8. Fuel 1 Stat. Closed Loop
- 9. Fuel 2 Stat. Not used
- 10. Load value 25.5%

1st, 2nd or 3rd in parentheses here represents which position in the order the malfunction is detected.

Freeze Frame Data

ECM stores the engine and driving conditions (in the form of data as shown at the left) at the moment of the detection of a malfunction in its memory. This data is called “Freeze frame data”.

Therefore, it is possible to know engine and driving conditions (e.g., whether the engine was warm or not, where the vehicle was running or stopped, where air/fuel mixture was lean or rich) when a malfunction was detected by checking the freeze frame data. Also, ECM has a function to store each freeze frame data for three different malfunctions in the order as the malfunction is detected. Utilizing this function, it is possible to know the order of malfunctions that have been detected. Its use is helpful when rechecking or diagnosing a trouble.

Priority of freeze frame data:

ECM has 4 frames where the freeze frame data can be stored. The first frame stores the freeze frame data of the malfunction which was detected first. However, the freeze frame data stored in this frame is updated according to the priority described below. (If malfunction as described in the upper square “1” below is detected while the freeze frame data in the lower square “2” has been stored, the freeze frame data “2” will be updated by the freeze frame data “1”.)

PRIORITY	FREEZE FRAME DATA IN FRAME 1
1	Freeze frame data at initial detection of malfunction among misfire detected (P0300-P0304), fuel system too lean (P0171) and fuel system too rich (P0172)
2	Freeze frame data when a malfunction other than those in “1” above is detected

In the 2nd through the 4th frames, the freeze frame data of each malfunction is stored in the order as the malfunction is detected. These data are not updated. Shown in the table below are examples of how freeze frame data are stored when two or more malfunctions are detected.

FRAME MALFUNCTION DETECTED ORDER		FRAME 1	FRAME 2	FRAME 3	FRAME 4
		FREEZE FRAME DATA to be updated	1st FREEZE FRAME DATA	2nd FREEZE FRAME DATA	3rd FREEZE FRAME DATA
	No malfunction	No freeze frame data			
1	P0400 (EGR) detected	Data at P0400 detection	Data at P0400 detection	-	-
2	P0171 (Fuel system) detected	Data at P0171 detection	Data at P0400 detection	Data at P0171 detection	-
3	P0300 (Misfire) detected	Data at P0171 detection	Data at P0400 detection	Data at P0171 detection	Data at P0300 detection
4	P0301 (Misfire) detected	Data at P0171 detection	Data at P0400 detection	Data at P0171 detection	Data at P0300 detection

Freeze frame data clearance:

The freeze frame data is cleared at the same time as clearance of diagnostic trouble code (DTC).

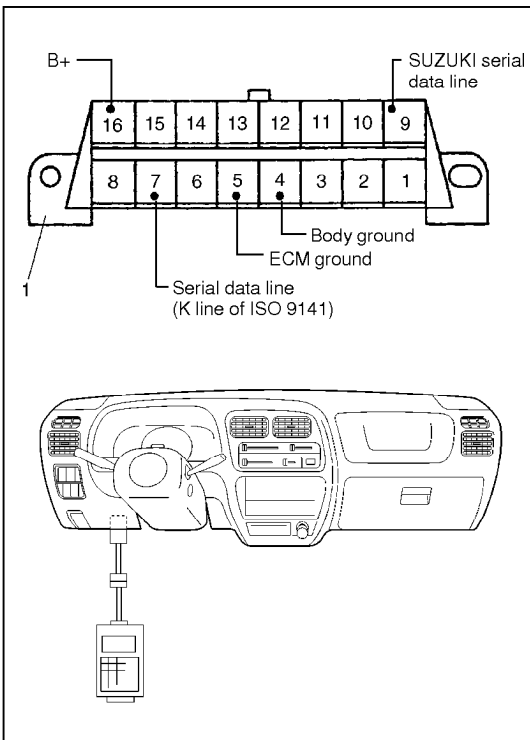

Data Link Connector (DLC)

DLC (1) is in compliance with SAEJ1962 in its installation position, the shape of connector and pin assignment. Serial data line (K line of ISO 9141) is used for SUZUKI scan tool (Tech-1) or generic scan tool to communicate with ECM. SUZUKI serial data line is used for SUZUKI scan tool (Tech-1) to communicate with immobilizer control module.

ON-BOARD DIAGNOSTIC SYSTEM (VEHICLE WITHOUT EGR VALVE)

ECM diagnosis troubles which may occur in the area including the following parts when the ignition switch is ON and the engine is running, and indicates the result by turning on or flashing malfunction indicator lamp (1).

- ECT sensor
- TP sensor
- IAT sensor
- MAP sensor
- CMP sensor
- CKP sensor
- VSS
- CPU (Central Processing Unit) of ECM

ECM and malfunction indicator lamp (1) operate as follows.

- Malfunction indicator lamp (1) lights when the ignition switch is turned ON (but the engine at stop) with the diagnosis switch terminal ungrounded regardless of the condition of Engine and Emission Control system. This is only to check the malfunction indicator lamp (1) bulb and its circuit.
 - If the above areas of Engine and Emission Control system is free from any trouble after the engine start (while engine is running), malfunction indicator lamp (1) turns OFF.
 - When ECM detects a trouble which has occurred in the above areas, it makes malfunction indicator lamp (1) turn ON while the engine is running to warn the driver of such occurrence of trouble and at the same time it stores the trouble area in ECM back-up memory. (The memory is kept as it is even if the trouble was only temporary and disappeared immediately. And it is not erased unless the power to ECM is shut off for specified time below.)
- ECM also indicates trouble area in memory by means of flashing of malfunction indicator lamp (1) at the time of inspection. (i.e. when connecting diagnosis switch terminal (2) and ground terminal (4) of monitor connector (3) with a service wire (5) and ignition switch is turned ON.)

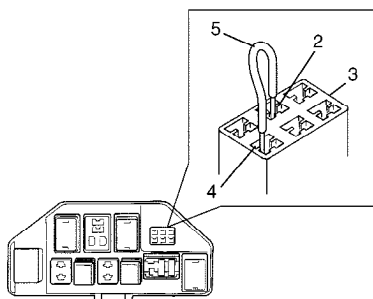
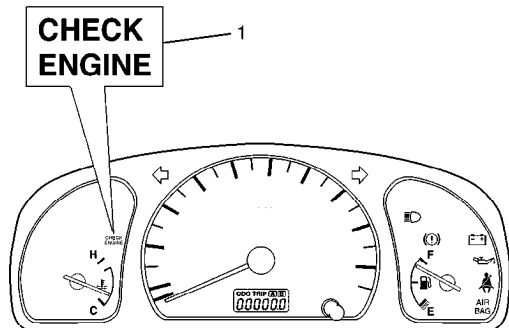

NOTE:

- **When a trouble occurs in the above areas and disappears soon while the diagnosis switch terminal is ungrounded and the engine is running, malfunction indicator lamp (1) lights and remains ON as long as the trouble exists but it turns OFF when the normal condition is restored.**
- **Time required to erase diagnostic trouble code memory thoroughly varies depending on ambient temperature as follows.**

AMBIENT TEMPERATURE	TIME TO CUT POWER TO ECM
Over 0°C (32°F)	60 sec. or longer
Under 0°C (32°F)	Not specifiable. Select a place with higher than 0°C (32°F) temperature.

PRECAUTION IN DIAGNOSING TROUBLE

- Don't disconnect couplers from ECM, battery cable at battery, ECM ground wire harness from engine or main fuse before confirming diagnostic information (DTC, freeze frame data, etc.) stored in ECM memory. Such disconnection will erase memorized information in ECM memory.
- Diagnostic information stored in ECM memory can be cleared as well as checked by using SUZUKI scan tool (Tech-1) or generic scan tool. Before using scan tool, read its Operator's (Instruction) Manual carefully to have good understanding as to what functions are available and how to use it.
- Priorities for diagnosing troubles (Vehicle with EGR valve).
If multiple diagnostic trouble codes (DTCs) are stored, proceed to the flow table of the DTC which has detected earliest in the order and follow the instruction in that table.
If no instructions are given, troubleshoot diagnostic trouble codes according to the following priorities.
 1. Diagnostic trouble codes (DTCs) other than DTC P0171/P0172 (Fuel system too lean/too rich), DTC P0300/P0301/P0302/P0303/P0304 (Misfire detected) and DTC P0400 (EGR flow malfunction)
 2. DTC P0171/P0172 (Fuel system too lean/too rich) and DTC P0400 (EGR flow malfunction)
 3. DTC P0300/P0301/P0302/P0303/P0304 (Misfire detected)
- Be sure to read "Precautions for Electrical Circuit Service" in Section 0A before inspection and observe what is written there.
- ECM Replacement
When substituting a known-good ECM, check for following conditions. Neglecting this check may cause damage to a known-good ECM.
 - Resistance value of all relays, actuators is as specified respectively.
 - MAP sensor and TP sensor are in good condition and none of power circuits of these sensors is shorted to ground.

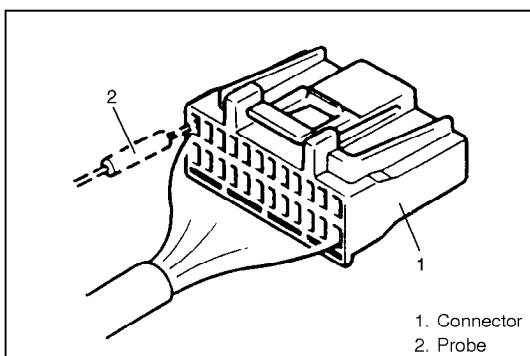

- When taking measurements at electrical connectors using a tester probe, be sure to insert the probe from the wire harness side (backside) of the connector.

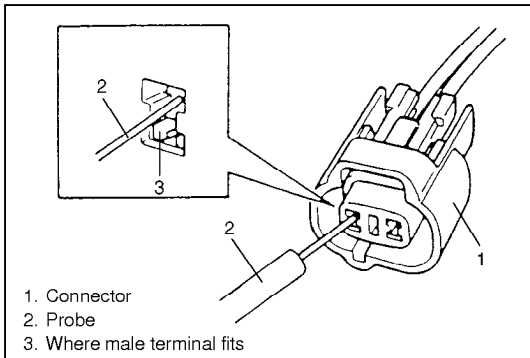

- When connecting meter probe from terminal side of coupler because it can't be connected from harness side, use extra care not to bend male terminal of coupler or force its female terminal open for connection.

In case of such connector as shown connect probe as shown to avoid opening female terminal.

Never connect probe where male terminal is supposed to fit.

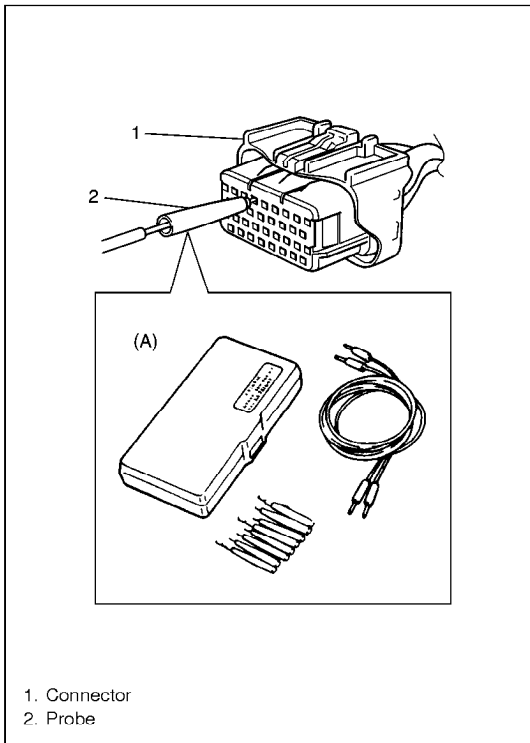

In case of such connector as shown, connect connector test adaptor and probe.

Special tool

(A): 09932-76010

(Connector test adaptor and shorting bar release tool)

- When checking connection of terminals, check its male half for bend and female half for excessive opening and both for locking (looseness), corrosion, dust, etc.

ENGINE DIAGNOSTIC FLOW TABLE

Refer to the following pages for the details of each step.

STEP	ACTION	YES	NO
1	Customer Complaint Analysis 1) Perform customer complaint analysis referring to the next page. Was customer complaint analysis performed?	Go to Step 2.	Perform customer complaint analysis.
2	Diagnostic Trouble Code (DTC) and Freeze Frame Data Check, Record and Clearance 1) Check for DTC (including pending DTC) referring to the next page. Is there any DTC(s)?	1) Print DTC and freeze frame data or write them down and clear them by referring to "DTC Clearance" section. 2) Go to Step 3.	Go to Step 4.
3	Visual Inspection 1) Perform visual inspection referring to the next page. Is there any faulty condition?	1) Repair or replace malfunction part. 2) Go to Step 11.	Go to Step 5.
4	Visual Inspection 1) Perform visual inspection referring to the next page. Is there any faulty condition?		Go to Step 8.
5	Trouble Symptom Confirmation 1) Confirm trouble symptom referring to the next page. Is trouble symptom identified?	Go to Step 6.	Go to Step 7.
6	Rechecking and Record of DTC/Freeze Frame Data 1) Recheck for DTC and freeze frame data referring to "DTC Check" section. Is there any DTC(s)?	Go to Step 9.	Go to Step 8.
7	Rechecking and Record of DTC/Freeze Frame Data 1) Recheck for DTC and freeze frame data referring to "DTC Check" section. Is there any DTC(s)?		Go to Step 10.
8	Engine Basic Inspection and Engine Diagnosis Table 1) Check and repair according to "Engine Basic Check" and "Engine Diagnosis Table" section. Are check and repair complete?	Go to Step 11.	1) Check and repair malfunction part(s). 2) Go to Step 11.
9	Trouble shooting for DTC 1) Check and repair according to applicable DTC diag. flow table. Are check and repair complete?		
10	Check for Intermittent Problems 1) Check for intermittent problems referring to the next page. Is there any faulty condition?	1) Repair or replace malfunction part(s). 2) Go to Step 11.	Go to Step 11.
11	Final Confirmation Test 1) Clear DTC if any. 2) Perform final confirmation test referring to the next page. Is there any problem symptom, DTC or abnormal condition?	Go to Step 6.	End.

1. CUSTOMER COMPLAINT ANALYSIS

Record details of the problem (failure, complaint) and how it occurred as described by the customer. For this purpose, use of such an inspection form will facilitate collecting information to the point required for proper analysis and diagnosis.

2. DIAGNOSTIC TROUBLE CODE (DTC)/FREEZE FRAME DATA CHECK, RECORD AND CLEARANCE

First, check DTC (including pending DTC), referring to “DTC check” section. If DTC is indicated, print it and freeze frame data or write them down and then clear them by referring to “DTC clearance” section. DTC indicates malfunction that occurred in the system but does not indicate whether it exists now or it occurred in the past and the normal condition has been restored now. To check which case applies, check the symptom in question according to Step 4 and recheck DTC according to Step 5.

Attempt to diagnose a trouble based on DTC in this step only or failure to clear the DTC in this step will lead to incorrect diagnosis, trouble diagnosis of a normal circuit or difficulty in troubleshooting.

NOTE:

If only Immobilizer DTCs (P1620-P1623) are indicated in this step, perform trouble diagnosis according to “Diagnosis” in Section 8G.

3. and 4. VISUAL INSPECTION

As a preliminary step, be sure to perform visual check of the items that support proper function of the engine referring to “Visual Inspection” section.

5. TROUBLE SYMPTOM CONFIRMATION

Based on information obtained in Step 1 Customer complaint analysis and Step 2 DTC/freeze frame data check, confirm trouble symptoms. Also, reconfirm DTC according to “DTC Confirmation Procedure” described in each DTC Diagnosis section.

6. and 7. RECHECKING AND RECORD OF DTC/FREEZE FRAME DATA

Refer to “DTC check” section for checking procedure.

8. ENGINE BASIC INSPECTION AND ENGINE DIAGNOSIS TABLE

Perform basic engine check according to the “Engine Basic Inspection Flow Table” first. When the end of the flow table has been reached, check the parts of the system suspected as a possible cause referring to ENGINE DIAGNOSIS TABLE and based on symptoms appearing on the vehicle (symptoms obtained through steps of customer complaint analysis, trouble symptom confirmation and/or basic engine check) and repair or replace faulty parts, if any.

9. TROUBLESHOOTING FOR DTC (See each DTC Diag. Flow Table)

Based on the DTC indicated in Step 5 and referring to the applicable DTC diag. flow table in this section, locate the cause of the trouble, namely in a sensor, switch, wire harness, connector, actuator, ECM or other part and repair or replace faulty parts.

10. CHECK FOR INTERMITTENT PROBLEM

Check parts where an intermittent trouble is easy to occur (e.g., wire harness, connector, etc.), referring to “INTERMITTENT AND POOR CONNECTION” in Section 0A and related circuit of DTC recorded in Step 2.

11. FINAL CONFIRMATION TEST

Confirm that the problem symptom has gone and the engine is free from any abnormal conditions. If what has been repaired is related to the DTC, clear the DTC once, perform DTC confirmation procedure and confirm that no DTC is indicated.

CUSTOMER PROBLEM INSPECTION FORM (EXAMPLE)

User name:	Model:	VIN:	
Date of issue:	Date Reg.	Date of problem:	Mileage:

PROBLEM SYMPTOMS	
<input type="checkbox"/> Difficult Starting <input type="checkbox"/> No cranking <input type="checkbox"/> No initial combustion <input type="checkbox"/> No combustion <input type="checkbox"/> Poor starting at (<input type="checkbox"/> cold <input type="checkbox"/> warm <input type="checkbox"/> always) <input type="checkbox"/> Other _____	<input type="checkbox"/> Poor Driveability <input type="checkbox"/> Hesitation on acceleration <input type="checkbox"/> Back fire/ <input type="checkbox"/> After fire <input type="checkbox"/> Lack of power <input type="checkbox"/> Surging <input type="checkbox"/> abnormal knocking <input type="checkbox"/> Other _____
<input type="checkbox"/> Poor Idling <input type="checkbox"/> Poor fast idle <input type="checkbox"/> Abnormal idling speed (<input type="checkbox"/> High <input type="checkbox"/> Low) (_____ r/min.) <input type="checkbox"/> Unstable <input type="checkbox"/> Hunting (_____ r/min. to _____ r/min.) <input type="checkbox"/> Other _____	<input type="checkbox"/> Engine Stall when <input type="checkbox"/> Immediately after start <input type="checkbox"/> Accel. pedal is depressed <input type="checkbox"/> Accel. pedal is released <input type="checkbox"/> Load is applied <input type="checkbox"/> A/C <input type="checkbox"/> Electric load <input type="checkbox"/> P/S <input type="checkbox"/> Other _____ <input type="checkbox"/> Other _____
<input type="checkbox"/> OTHERS:	

VEHICLE/ENVIRONMENTAL CONDITION WHEN PROBLEM OCCURS	
Environmental Condition	
Weather	<input type="checkbox"/> Fair <input type="checkbox"/> Cloudy <input type="checkbox"/> Rain <input type="checkbox"/> Snow <input type="checkbox"/> Always <input type="checkbox"/> Other _____
Temperature	<input type="checkbox"/> Hot <input type="checkbox"/> Warm <input type="checkbox"/> Cool <input type="checkbox"/> Cold (_____ °F/ _____ °C) <input type="checkbox"/> Always
Frequency	<input type="checkbox"/> Always <input type="checkbox"/> Sometimes (_____ times/ _____ day, month) <input type="checkbox"/> Only once <input type="checkbox"/> Under certain condition
Road	<input type="checkbox"/> Urban <input type="checkbox"/> Suburb <input type="checkbox"/> Highway <input type="checkbox"/> Mountainous (<input type="checkbox"/> Uphill <input type="checkbox"/> Downhill) <input type="checkbox"/> Tarmacadam <input type="checkbox"/> Gravel <input type="checkbox"/> Other _____
Vehicle Condition	
Engine condition	<input type="checkbox"/> Cold <input type="checkbox"/> Warming up phase <input type="checkbox"/> Warmed up <input type="checkbox"/> Always <input type="checkbox"/> Other at starting <input type="checkbox"/> Immediately after start <input type="checkbox"/> Racing without load <input type="checkbox"/> Engine speed (_____ r/min)
Vehicle condition	During driving: <input type="checkbox"/> Constant speed <input type="checkbox"/> Accelerating <input type="checkbox"/> Decelerating <input type="checkbox"/> Right hand corner <input type="checkbox"/> Left hand corner <input type="checkbox"/> When shifting (Lever position _____) <input type="checkbox"/> At stop <input type="checkbox"/> Vehicle speed when problem occurs (_____ km/h, _____ Mile/h) <input type="checkbox"/> Other _____

Malfunction indicator lamp condition	<input type="checkbox"/> Always ON <input type="checkbox"/> Sometimes ON <input type="checkbox"/> Always OFF <input type="checkbox"/> Good condition
Diagnostic trouble code	First check: <input type="checkbox"/> No code <input type="checkbox"/> Malfunction code (_____)
	Second check: <input type="checkbox"/> No code <input type="checkbox"/> Malfunction code (_____)

NOTE:

The above form is a standard sample. It should be modified according to conditions characteristic of each market.

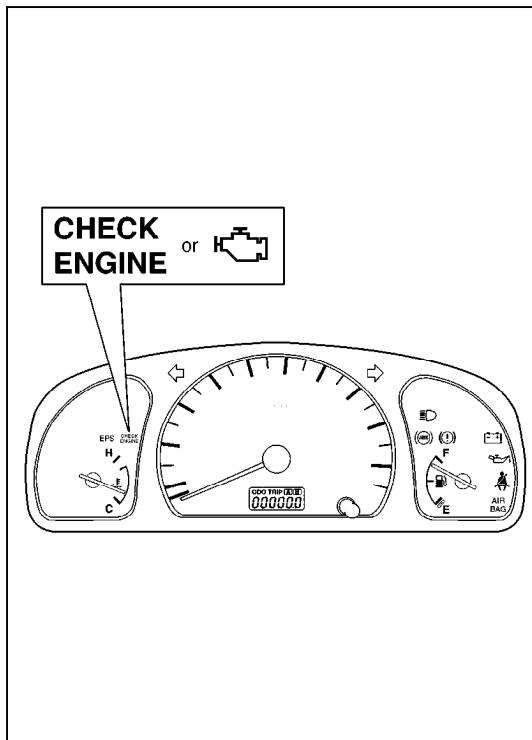

MALFUNCTION INDICATOR LAMP (MIL) CHECK

- 1) Turn ON ignition switch (but the engine at stop) and check that MIL lights.
If MIL does not light up (or MIL dims), go to "Diagnostic Flow Table A-1" for troubleshooting.
If MIL flashes, go to "Diagnostic Flow Table A-3" for troubleshooting (vehicle without EGR valve).
- 2) Start engine and check that MIL turns OFF.
If MIL remains ON and no DTC is stored in ECM, go to "Diagnostic Flow Table A-2" for troubleshooting.

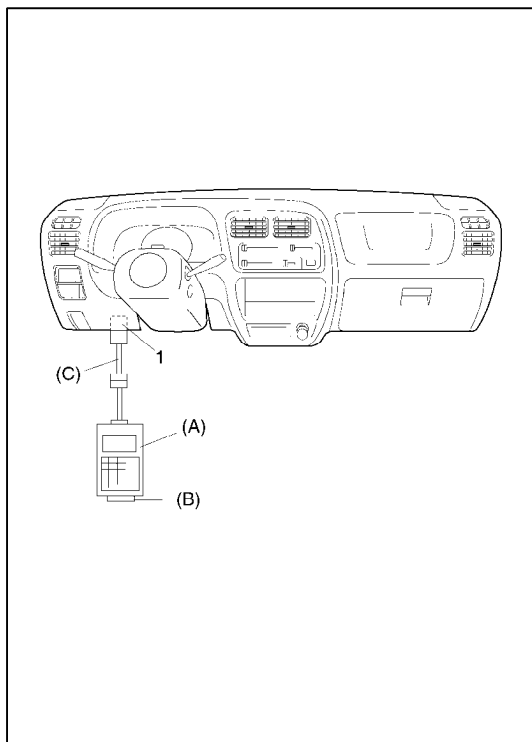

DIAGNOSTIC TROUBLE CODE (DTC) CHECK

[Using SUZUKI scan tool]

- 1) Prepare SUZUKI scan tool (Tech-1).
- 2) With ignition switch OFF, connect it to data link connector (DLC) (1) located on underside of instrument panel at driver's seat side.

Special Tool:

(A): 09931-76011 (SUZUKI scan tool)

(B): Mass storage cartridge

(C): 09931-76030 (16/14 pin DLC cable)

- 3) Turn ignition switch ON and confirm that MIL lights.
- 4) Read DTC, pending DTC and freeze frame data according to instructions displayed on scan tool and print it or write it down. Refer to scan tool operator's manual for further details.

If communication between scan tool and ECM is not possible, check if scan tool is communicable by connecting it to ECM in another vehicle. If communication is possible in this case, scan tool is in good condition. Then check data link connector and serial data line (circuit) in the vehicle with which communication was not possible.

- 5) After completing the check, turn ignition switch off and disconnect scan tool from data link connector.

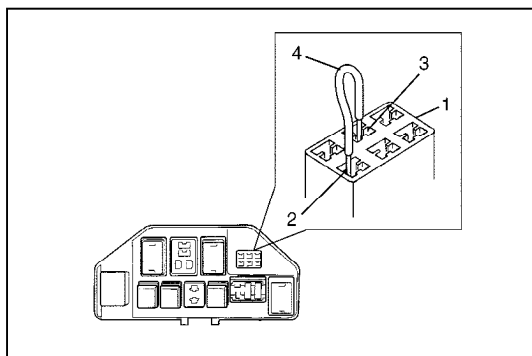

[Without using SUZUKI scan tool] (Vehicle without EGR valve)

- 1) Check malfunction indicator lamp referring to "Malfunction Indicator Lamp Check" in this section.
- 2) With the ignition switch OFF position, connect diagnosis switch terminal (3) and ground terminal (2) in monitor connector (1) with service wire (4).
- 3) With the ignition switch ON position and leaving engine OFF, read DTC from flashing pattern of malfunction indicator lamp. Refer to "Diagnostic Trouble Code Table".
If lamp does not flash or remains ON or OFF, go to "Diagnostic Flow Table A-4".

NOTE:

- If abnormality or malfunction lies in two or more areas, malfunction indicator lamp indicates applicable codes three times each.

And flashing of these codes is repeated as long as diagnosis terminal is grounded and ignition switch is held at ON position.

- Take a note of diagnostic trouble code indicated first.

- 4) After completing the check, turn the ignition switch OFF position and disconnect service wire from monitor coupler.

DIAGNOSTIC TROUBLE CODE (DTC) CLEARANCE**[Using SUZUKI scan tool]**

- 1) Connect SUZUKI scan tool (Tech-1) to data link connector in the same manner as when making this connection for DTC check.
- 2) Turn ignition switch ON.
- 3) Erase DTC and pending DTC according to instructions displayed on scan tool. Refer to scan tool operator's manual for further details.
- 4) After completing the clearance, turn ignition switch off and disconnect scan tool from data link connector.

NOTE:

DTC and freeze frame data stored in ECM memory are also cleared in following cases. Be careful not to clear them before keeping their record.

- When power to ECM is cut off (by disconnecting battery cable, removing fuse or disconnecting ECM connectors)
- When the same malfunction (DTC) is not detected again during 40 engine warm-up cycles.

[Without using SUZUKI scan tool]

- 1) Turn the ignition switch OFF position.
- 2) Disconnect battery negative cable for specified time below to erase diagnostic trouble code stored in ECM memory and reconnect it.

Time required to erase DTC:

Ambient temperature	Time to cut power to ECM
Over 0°C (32°F)	30 sec. or longer
Under 0°C (32°F)	Not specifiable. Select a place with higher than 0°C (32°F) temperature.

DIAGNOSTIC TROUBLE CODE (DTC) TABLE

DTC NO.	DETECTING ITEM	DETECTING CONDITION (DTC will set when detecting:)	MIL (vehicle with EGR valve)	MIL (vehicle without EGR valve)
P0105 (No.11)	Manifold absolute pressure circuit malfunction	Low pressure-high vacuum-low voltage (or MAP sensor circuit shorted to ground) High pressure-low vacuum-high voltage (or MAP sensor circuit open)	1 driving cycle	1 driving cycle
P0110 (No.18)	Intake air temp. circuit malfunction	Intake air temp. circuit low input Intake air temp. circuit high input	1 driving cycle	1 driving cycle
P0115 (No.19)	Engine coolant temp. circuit malfunction	Engine coolant temp. circuit low input Engine coolant temp. circuit high input	1 driving cycle	1 driving cycle
P0120 (No.13)	Throttle position circuit malfunction	Throttle position circuit low input Throttle position circuit high input	1 driving cycle	1 driving cycle
P0121	Throttle position circuit performance problem	Poor performance of TP sensor	2 driving cycles	Not applicable
P0130	HO2S circuit malfunction (Sensor-1)	Min. output voltage of HO2S-higher than specification Max. output voltage of HO2S-lower than specification	2 driving cycles	Not applicable
P0133	HO2S circuit slow response (Sensor-1)	Response time of HO2S-1 output voltage between rich and lean is longer than specification.	2 driving cycles	Not applicable
P0134 (No.14)	HO2S circuit no activity detected (Sensor-1)	Output voltage of HO2S-1 fails to go above or below specification (or circuit is open or short).	2 driving cycles	Not applicable
P0135	HO2S heater circuit malfunction (Sensor-1)	Terminal voltage is lower than specification at heater OFF or it is higher at heater ON.	2 driving cycles	Not applicable
P0136	HO2S circuit malfunction (Sensor-2)	HO2S-2 voltage is higher than specification	2 driving cycles	Not applicable
P0141	HO2S heater circuit malfunction (Sensor-2)	Terminal voltage is lower than specification at heater OFF or it is higher at heater ON. (or heater circuit or short)	2 driving cycles	Not applicable
P0148	Fuel pressure control valve circuit malfunction	Fuel pressure control valve circuit is open or shorted to ground.	☆1 driving cycle	Not applicable
P0171	Fuel system too lean	Short term fuel trim or total fuel trim (short and long terms added) is larger than specification for specified time or longer. (fuel trim toward rich side is large.)	2 driving cycles	Not applicable
P0172	Fuel system too rich	Short term fuel trim or total fuel trim (short and long term added) is smaller than specification for specified time or longer. (fuel trim toward lean side is large.)	2 driving cycles	Not applicable

DTC NO.	DETECTING ITEM	DETECTING CONDITION (DTC will set when detecting:)	MIL (vehicle with EGR valve)	MIL (vehicle without EGR valve)
P0300 P0301 P0302 P0303 P0304	Random misfire detected Cylinder 1 misfire detected Cylinder 2 misfire detected Cylinder 3 misfire detected Cylinder 4 misfire detected	Misfire of such level as to cause damage to three way catalyst	MIL flashing during misfire detection	Not applicable
		Misfire of such level as to deteriorate emission but not to cause damage to three way catalyst	2 driving cycles	Not applicable
P0335 (No.23)	Crankshaft position sensor circuit malfunction	No signal for 2 sec. During engine cranking	1 driving cycle	1 driving cycle
P0340 (No.15)	Camshaft position sensor circuit malfunction	No signal during engine running	1 driving cycle	1 driving cycle
P0400	Exhaust gas recirculation flow malfunction detected	Excessive or insufficient EGR flow	2 driving cycles	Not applicable
P0420	Catalyst system efficiency below threshold	Output waveforms of HO2S-1 and HO2S-2 are similar. (Time from output voltage change of HO2S-1 to that of HO2S-2 is shorter than specification.)	2 driving cycles	Not applicable
P0443	Purge control valve circuit malfunction	Purge control valve circuit is open or shorted to ground	2 driving cycles	Not applicable
P0480	Radiator cooling fan control circuit malfunction	Radiator cooling fan relay terminal voltage is low when fan command is not outputted	2 driving cycles	Not applicable
P0500 (No.16)	Vehicle speed sensor malfunction	No signal while running during fuel cut at decelerating	2 driving cycles	1 driving cycle
P0505	Idle control system malfunction	No closed signal to IAC valve is detected	2 driving cycles	Not applicable
P1450	Barometric pressure sensor circuit malfunction	Barometric pressure is lower or higher than specification. (or sensor malfunction)	1 driving cycle	Not applicable
P1451	Barometric pressure sensor performance problem	Difference between manifold absolute pressure (MAP sensor value) and barometric pressure (barometric pressure sensor value) is larger than specification during cranking.	2 driving cycles	Not applicable
P1500	Starter signal circuit malfunction	Starter signal is not inputted from engine cranking till its start and after or it is always inputted	2 driving cycles	Not applicable
P1510	ECM backup power source malfunction	No backup power after starting engine	1 driving cycle	Not applicable

DTC NO.	DETECTING ITEM	DETECTING CONDITION (DTC will set when detecting:)	MIL
P1620 (No.84)	ECU code not registered	Refer to Section 8G.	
P1621 (No.83)	No ECU code transmitted from Immobilizer Control Module		
P1622 (No.82)	Faulty in ECM		
P1623 (No.81)	ECU code not matched		

Note:

- For () marked No. in DTC column, it is used for vehicle without EGR valve.
- DTC No.12 appears when none of the other codes is identified (vehicle without EGR valve). It can be checked by flashing pattern of MIL.
- For star (☆) marked items in MIL column, MIL does not light even when DTC is detected. Bear this in mind when diagnosing troubles.

FAIL-SAFE TABLE

When any of the following DTCs is detected, ECM enters fail-safe mode as long as malfunction continues to exist but that mode is canceled when ECM detects normal condition after that.

DTC NO.	DETECTED ITEM	FAIL-SAFE OPERATION (SYMPTOM)
P0105 (No.11)	Manifold absolute pressure sensor circuit malfunction	<ul style="list-style-type: none"> ● ECM (PCM) uses value determined by throttle opening and engine speed. ● ECM (PCM) stops EGR, EVAP purge and idle air control.
P0110 (No.18)	Intake air temp. sensor circuit malfunction	<ul style="list-style-type: none"> ● ECM (PCM) controls actuators assuming that intake air temperature is 20°C (68°F). ● ECM (PCM) stops EGR and idle air control.
P0115 (No.19)	Engine coolant temp. sensor circuit malfunction	<ul style="list-style-type: none"> ● ECM (PCM) controls actuators assuming that engine coolant temperature is 80°C (176°F). ● ECM (PCM) operates radiator fan. ● ECM (PCM) stops EGR, A/C and idle air control.
P0120 (No.13)	Throttle position sensor circuit malfunction	<ul style="list-style-type: none"> ● ECM (PCM) controls actuators assuming that throttle opening is 20°. ● ECM (PCM) stops idle air control.
P0340 (No.15)	Camshaft position sensor circuit malfunction	ECM controls injection system sequential injection to synchronous injection. (Cranking for a few seconds to start engine)
P0500 (No.16)	Vehicle speed sensor malfunction	ECM stops idle air control.
P1450	Barometric pressure sensor low/high input	ECM controls actuators assuming that barometric pressure is 100 kPa (760 mmHg).

VISUAL INSPECTION

Visually check following parts and systems.

INSPECTION ITEM	REFERRING SECTION
<ul style="list-style-type: none"> ● Engine oil ----- level, leakage ● Engine coolant ----- level, leakage ● Fuel ----- level, leakage ● Air cleaner element ----- dirt, clogging ● Battery ----- fluid level, corrosion of terminal ● Water pump belt ----- tension, damage ● Throttle cable ----- play, installation ● Vacuum hoses of air intake system ----- disconnection, looseness, deterioration, bend ● Connectors of electric wire harness ----- disconnection, friction ● Fuses ----- burning ● Parts ----- installation, bolt ----- looseness ● Parts ----- deformation ● Other parts that can be checked visually 	<p>Section 0B Section 0B Section 0B Section 0B Section 0B Section 6E Section 6E Section 8</p>
<p>Also check following items at engine start, if possible</p> <ul style="list-style-type: none"> ● Malfunction indicator lamp ● Charge warning lamp ● Engine oil pressure warning lamp ● Engine coolant temp. meter ● Fuel level meter <div style="display: flex; align-items: center; margin-left: 100px;"> <div style="border-left: 1px solid black; border-right: 1px solid black; height: 20px; margin-right: 5px;"></div> <div style="border-left: 1px solid black; border-right: 1px solid black; height: 20px; margin-right: 5px;"></div> <div style="border-left: 1px solid black; border-right: 1px solid black; height: 20px; margin-right: 5px;"></div> <div style="border-left: 1px solid black; border-right: 1px solid black; height: 20px; margin-right: 5px;"></div> <div style="border-left: 1px solid black; border-right: 1px solid black; height: 20px; margin-right: 5px;"></div> <div style="margin-left: 5px;">} Operation</div> </div> <ul style="list-style-type: none"> ● Abnormal air being inhaled from air intake system ● Exhaust system ----- leakage of exhaust gas, noise ● Other parts that can be checked visually 	<p>Section 6 Section 6H Section 8 (section 6 for pressure check) Section 8 Section 8</p>

ENGINE BASIC INSPECTION

This check is very important for troubleshooting when ECM has detected no DTC and no abnormality has been found in visual inspection.

Follow the flow table carefully.

STEP	ACTION	YES	NO
1	Was "ENGINE DIAG. FLOW TABLE" performed?	Go to Step 2.	Go to "ENGINE DIAG. FLOW TABLE".
2	Check battery voltage. Is it 11 V or more?	Go to Step 3.	Charge or replace battery.
3	Is engine cranked?	Go to Step 4.	Go to "DIAGNOSIS" in Section 6G.
4	Does engine start?	Go to Step 5.	Go to Step 7.
5	Check idle speed as follows: 1) Warm up engine to normal operating temp. 2) Shift transmission to neutral position. 3) All of electrical loads are switched off. 4) Check engine idle speed with scan tool. See Fig. 1. Is it 700 – 800 r/min?	Go to Step 6.	Go to "ENGINE DIAGNOSIS TABLE".
6	Check ignition timing as follows: 1) When not using SUZUKI scan tool, disconnect scan tool from DLC and connect test switch terminal of monitor coupler to ground. See Fig. 2. When using SUZUKI scan tool, select "MISC" mode on SUZUKI scan tool and fix ignition timing to initial one. See Fig. 3. 2) Open the engine service hole cover behind the front seats and remove the inspection hole cap on the transmission case to observe ignition timing. 3) Using timing light (1), check initial ignition timing. See Fig. 4. Is it $5^{\circ} \pm 3^{\circ}$ BTDC at specified idle speed?	Go to "ENGINE DIAGNOSIS TABLE".	Check ignition control related parts referring to Section 6F.
7	Check immobilizer system malfunction as follows (if equipped): 1) Check MIL (malfunction indicator lamp) for flashing. Is it flashing when ignition switch is turned to ON position?	Go to "DIAGNOSIS" in Section 8G.	Go to Step 8.
8	Check fuel supply as follows: 1) Check to make sure that enough fuel is filled in fuel tank. 2) Turn ON ignition switch for 2 seconds and then OFF. See Fig. 5. Is fuel return pressure (returning sounds) felt from fuel feed hose (1) when ignition switch is turned ON?	Go to Step 10.	Go to Step 9.
9	Check fuel pump for operating. 1) Was fuel pump operating sound heard from fuel filler for about 2 seconds after ignition switch ON and stop?	Go to "DIAG. FLOW TABLE B-3".	Go to "DIAG. FLOW TABLE B-2".

STEP	ACTION	YES	NO
10	Check ignition spark as follows: 1) Disconnect injector couplers. 2) Remove spark plugs and connect them to high tension cords. 3) Ground spark plugs. 4) Crank engine and check if each spark plug sparks. Is it in good condition?	Go to Step 11.	Go to "DIAGNOSIS" in Section 6F.
11	Check fuel injector for operation as follows: 1) Install spark plugs and connect injector connectors. 2) Using sound scope (1), check operating sound of each injector (2) when cranking engine. See Fig. 6. Was injector operating sound heard from all injectors?	Go to "ENGINE DIAGNOSIS TABLE".	Go to "DIAG. FLOW TABLE B-1".

Fig. 1 for Step 5



Fig. 2 for Step 6

When not using SUZUKI scan tool:

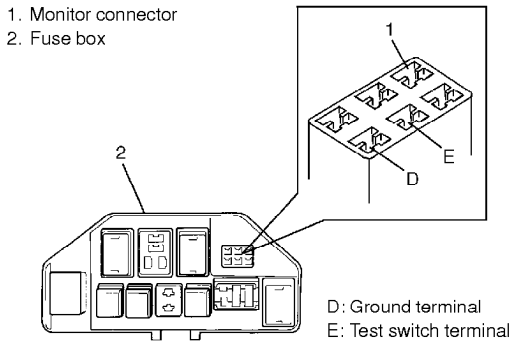

Fig. 3 for Step 6

When using SUZUKI scan tool

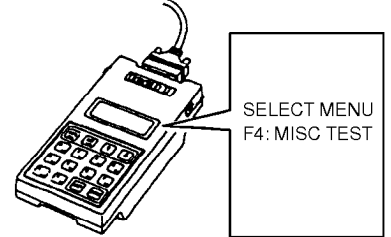

Fig. 4 for Step 6

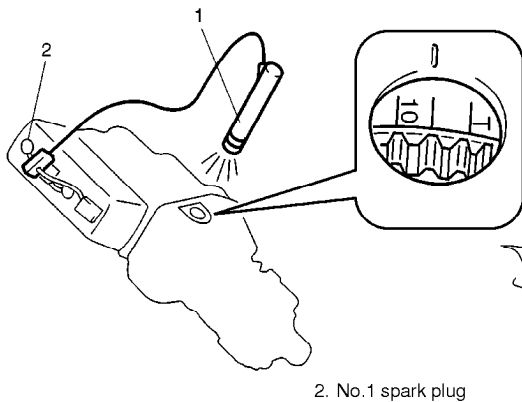

Fig. 5 for Step 8

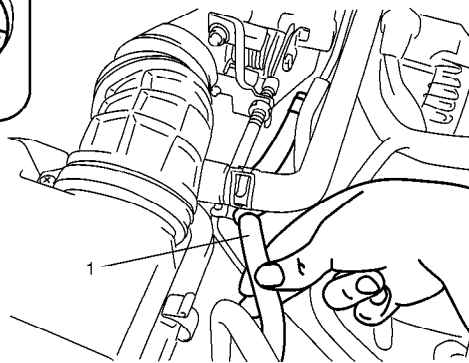
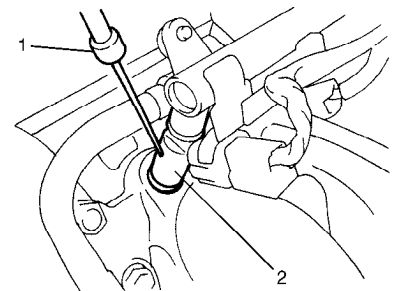

Fig. 6 for Step 11



ENGINE DIAGNOSIS TABLE

Perform troubleshooting referring to following table when ECM has no DTC and no abnormality found in visual inspection and engine basic inspection previously.

Condition	Possible Cause	Referring Item
Hard Starting (Engine cranks OK)	<p>Ignition system out of order</p> <ul style="list-style-type: none"> ● Faulty ignition coil or high-tension cord <p>Engine and emission control system out of order</p> <ul style="list-style-type: none"> ● Faulty CMP sensing rotor or CKP sensing rotor ● Faulty idle air control system ● Faulty ECT sensor, TP sensor, CKP sensor, CMP sensor or MAP sensor ● Fuel pressure out of specification ● Faulty fuel injector ● Faulty ECM ● Malfunctioning PCV system <p>Low compression</p> <ul style="list-style-type: none"> ● Improper valve lash ● Improper valve timing ● Compression leak from valve seat ● Sticky valve stem ● Weak or damaged valve springs ● Compression leak at cylinder head gasket ● Sticking or damaged piston ring ● Worn piston, ring or cylinder ● Faulty fuel pressure control valve 	<p>Diagnosis in Section 6F.</p> <p>CMP sensing rotor or CKP sensing rotor inspection in Section 6E. Diagnostic Flow Table B-4 ECT sensor, TP sensor, CKP sensor, CMP sensor or MAP sensor in Section 6E. Diagnostic Flow Table B-3 Diagnostic Flow Table B-1 Inspection of ECM and its circuit in Section 6E. PCV hose and PCV valve in Section 6E.</p> <p>Compression check in Section 6A. Valve lash check in Section 6A. Timing belt and belt tensioner in Section 6A. Valves and cylinder head in Section 6A. Valves and cylinder head in Section 6A. Valves spring in Section 6A. Valves and cylinder head in Section 6A. Piston rings in Section 6A. Pistons and piston rings in Section 6A. Fuel pressure control valve in Section 6E.</p>

Condition	Possible Cause	Reference Item
Engine has no power	<p>Engine overheating</p> <p>Ignition system out of order</p> <ul style="list-style-type: none"> ● Faulty ignition coil or high-tension cord <p>Engine and emission control system out of order.</p> <ul style="list-style-type: none"> ● Fuel pressure out of specification ● Faulty injector ● Faulty TP sensor, ECT sensor or MAP sensor ● Faulty ECM ● Malfunctioning EGR valve (if equipped) ● Maladjusted accelerator cable play <p>Low compression</p> <p>Others</p> <ul style="list-style-type: none"> ● Dragging brakes ● Slipping clutch 	<p>Refer to "Overheating" of this table.</p> <p>Diagnosis in Section 6F.</p> <p>Diagnostic Flow Table B-3 Diagnostic Flow Table B-1 TP sensor, ECT sensor or MAP sensor in Section 6E. Inspection of ECM and its circuit in Section 6E. EGR system inspection in Section 6E. Accelerator cable play in Section 6E.</p> <p>Previously outlined.</p> <p>Diagnosis in Section 5. Diagnosis in Section 7C.</p>
Improper engine idling or engine fails to idle	<p>Ignition system out of order</p> <ul style="list-style-type: none"> ● Faulty ignition coil or high-tension cord <p>Engine overheating</p> <p>Engine and emission control system out of order.</p> <ul style="list-style-type: none"> ● Fuel pressure out of specification ● Faulty idle air control system ● Faulty evaporative emission control system ● Faulty injector ● Faulty ECT sensor, TP sensor or MAP sensor ● Malfunctioning PCV system ● Faulty ECM ● Faulty EGR system (if equipped) <p>Low compression</p> <p>Others</p>	<p>Diagnosis in Section 6F.</p> <p>Refer to "Overheating" of this table.</p> <p>Diagnostic Flow Table B-3 Diagnostic Flow Table B-4 EVAP control system check in Section 6E.</p> <p>Diagnostic Flow Table B-1 ECT sensor, TP sensor or MAP sensor in Section 6E. PCV hose and PCV valve in Section 6F. Inspection of ECM and its circuit in Section 6E. EGR system in Section 6E.</p> <p>Previously outlined.</p>

Condition	Possible Cause	Reference Item
<p>Engine hesitates (Momentary lack of response as the accelerator is depressed. Can occur at all vehicle speeds. Usually most severe when first trying to make the vehicle move, as from a stop sign.)</p>	<p>Ignition system out of order</p> <ul style="list-style-type: none"> ● Faulty ignition coil or high-tension cords <p>Engine overheating</p> <p>Engine and emission control system out of order.</p> <ul style="list-style-type: none"> ● Fuel pressure out of specification ● Faulty injector ● Faulty TP sensor, ECT sensor or MAP sensor ● Faulty ECM ● Malfunctioning EGR valve (if equipped) <p>Low compression</p>	<p>Diagnosis in Section 6F.</p> <p>Refer to "Overheating" of this table.</p> <p>Diagnostic Flow Table B-3 Diagnostic Flow Table B-1 TP sensor, ECT sensor or MAP sensor in Section 6E. Inspection of ECM and its circuit in Section 6E. EGR system in Section 6E.</p> <p>Previously outlined.</p>
<p>Surges (Engine power variation under steady throttle or cruise. Feels like the vehicle speeds up and down with no change in the accelerator pedal.)</p>	<p>Ignition system out of order</p> <ul style="list-style-type: none"> ● Faulty ignition coil or high-tension cord <p>Engine and emission control system out of order.</p> <ul style="list-style-type: none"> ● Variable fuel pressure ● Faulty MAP sensor (if equipped) ● Faulty injector ● Faulty ECM ● Malfunctioning EGR valve (if equipped) 	<p>Diagnosis in Section 6F.</p> <p>Diagnostic Flow Table B-3 MAP sensor in Section 6E. Diagnostic Flow Table B-1 Inspection of ECM and its circuit in Section 6E. EGR system in Section 6E.</p>
<p>Excessive detonation (The engine makes sharp metallic knocks that change with throttle opening. Sounds like pop corn popping.)</p>	<p>Engine overheating</p> <p>Ignition system out of order.</p> <ul style="list-style-type: none"> ● Faulty spark plug <p>Engine and emission control system out of order.</p> <ul style="list-style-type: none"> ● Clogged fuel filter and fuel lines ● Malfunctioning EGR valve (if equipped) ● Poor performance of ECT sensor or MAP sensor ● Faulty injector ● Faulty ECM <p>Others</p> <ul style="list-style-type: none"> ● Excessive combustion chamber deposits 	<p>Refer to "Overheating" of this table.</p> <p>Spark plugs in Section 6F.</p> <p>Diagnostic Flow Table B-3 EGR system in Section 6E. ECT sensor or MAP sensor in Section 6E. Diagnostic Flow Table B-1 Inspection of ECM and its circuit in Section 6E.</p> <p>Piston and cylinder head in Section 6A.</p>

Condition	Possible Cause	Reference Item
Overheating	<ul style="list-style-type: none"> ● Inoperative thermostat ● Faulty radiator fan motor or its circuit ● Loose or slip water pump belt ● Poor water pump performance ● Clogged or leaky radiator ● Improper engine oil grade ● Clogged oil filter or oil strainer ● Poor oil pump performance ● Dragging brakes ● Slipping clutch ● Blown cylinder head gasket 	<p>Thermostat in Section 6B.</p> <p>Radiator fan control system check in Section 6E.</p> <p>ITEM1-1 Drive belt inspection and change in Section 0B.</p> <p>Water pump in Section 6B.</p> <p>Radiator in Section 6B.</p> <p>ITEM1-4 Engine oil and oil filter change in Section 0B.</p> <p>Oil pressure check in Section 6A.</p> <p>Oil pressure check in Section 6A.</p> <p>Diagnosis in Section 5.</p> <p>Diagnosis in Section 7C.</p> <p>Valves and cylinder head inspection in Section 6A.</p>
Poor gasoline mileage	<p>Ignition system out of order.</p> <ul style="list-style-type: none"> ● Faulty ignition coil or high-tension cord <p>Engine and emission control system out of order.</p> <ul style="list-style-type: none"> ● Fuel pressure out of specification ● Faulty TP sensor, ECT sensor or MAP sensor ● Faulty injector ● Faulty ECM ● Malfunctioning EGR valve (if equipped) ● High idle speed <p>Low compression</p> <p>Others</p> <ul style="list-style-type: none"> ● Poor valve seating ● Dragging brakes ● Slipping clutch ● Thermostat out of order ● Improper tire pressure 	<p>Diagnosis in Section 6F.</p> <p>Diagnostic Flow Table B-3 TP sensor, ECT sensor or MAP sensor in Section 6E.</p> <p>Diagnostic Flow Table B-1 Inspection of ECM and its circuit in Section 6E.</p> <p>EGR system in Section 6E.</p> <p>Refer to item "Improper engine idle speed" previously outlined.</p> <p>Previously outlined.</p> <p>Valves and cylinder head in Section 6A.</p> <p>Diagnosis in Section 5.</p> <p>Diagnosis in Section 7C.</p> <p>Thermostat in Section 6B.</p> <p>Refer to Section 3F.</p>

Condition	Possible Cause	Reference Item
Excessive engine oil consumption	Oil entering combustion chamber <ul style="list-style-type: none"> ● Sticky piston ring ● Worn piston and cylinder ● Worn piston ring groove and ring ● Improper location of piston ring gap ● Worn or damaged valve stem seal ● Worn valve stem 	Piston and cylinder in Section 6A. Cylinders, pistons and piston rings in Section 6A. Pistons and piston rings in Section 6A. Pistons installation in Section 6A. Valves and cylinder head in Section 6A. Valves inspection in Section 6A.
Low oil pressure	<ul style="list-style-type: none"> ● Improper oil viscosity ● Malfunctioning oil pressure switch ● Clogged oil strainer ● Functional deterioration of oil pump ● Worn oil pump relief valve ● Excessive clearance in various sliding parts 	ITEM1-4 Engine oil and oil filter change in Section 0B. Oil pressure switch in Section 8. Oil pan and oil pump strainer in Section 6A. Oil pump in Section 6A. Oil pump in Section 6A. Refer to Section 6A.
Engine noise Note: Before checking the mechanical noise, make sure that: <ul style="list-style-type: none"> ● Ignition timing is properly adjusted. ● Specified spark plug is used. ● Specified fuel is used. 	Valve noise <ul style="list-style-type: none"> ● Improper valve lash ● Worn valve stem and guide ● Weak or broken valve spring ● Warped or bent valve ● Loose camshaft housing bolts Piston, ring and cylinder noise <ul style="list-style-type: none"> ● Worn piston, ring and cylinder bore Connecting rod noise <ul style="list-style-type: none"> ● Worn crankpin bearing ● Worn crankpin ● Loose connecting rod nuts ● Low oil pressure Crankshaft noise <ul style="list-style-type: none"> ● Low oil pressure ● Worn crankshaft journal bearing ● Worn crankshaft journal ● Loose lower crankcase (bearing cap) bolts ● Excessive crankshaft thrust play 	Valve lash in Section 6A. Valves and cylinder head in Section 6A. Valve springs in Section 6A. Valves and cylinder head in Section 6A. Camshaft in Section 6A. Pistons and cylinders in Section 6A. Crankpin and connecting rod bearing in Section 6A. Crankpin and connecting rod bearing in Section 6A. Connecting rod in Section 6A. Previously outlined. Previously outlined. Crankshaft and bearing in Section 6A. Crankshaft and bearing in Section 6A. Crankshaft in Section 6A. Crankshaft in Section 6A.

Condition	Possible Cause	Referring Item
Excessive hydrocarbon (HC) emission or Excessive carbon monoxide (CO) emission	<p>Ignition system out of order</p> <ul style="list-style-type: none"> ● Faulty ignition coil or high-tension cord <p>Engine and Emission control system out of order.</p> <ul style="list-style-type: none"> ● Fuel pressure out of specification ● Lead contamination of three way catalytic converter (if equipped) ● Malfunctioning PCV system ● Faulty EVAP control system ● Closed loop system (A/F feed back compensation) fails (vehicle with HO2S) <ul style="list-style-type: none"> – Faulty TP sensor – Faulty ECT sensor or MAP sensor – Faulty oxygen sensor ● Faulty injector ● Faulty ECM <p>Low compression</p>	<p>Diagnosis in Section 6F.</p> <p>Diagnostic Flow Table B-3 Maintenance in Section 6K.</p> <p>PCV hose and PCV valve in Section 6E. EVAP control system check in Section 6E. Check oxygen sensor output voltage. Refer to DTC P0130 Table in this section.</p> <p>Diagnostic Flow Table B-1 Inspection of ECM and its circuit in Section 6E.</p> <p>Previously outlined.</p>
Excessive nitrogen oxides (NOx) emission	<p>Engine and emission control system out of order</p> <ul style="list-style-type: none"> ● Fuel pressure out of specification ● Lead contamination of three way catalytic converter (if equipped) ● Closed loop system (A/F feed back compensation) fails <ul style="list-style-type: none"> – Faulty TP sensor – Faulty ECT sensor or MAP sensor – Faulty oxygen sensor ● Faulty injector ● Faulty ECM <p>● Faulty EGR system (if equipped)</p>	<p>Diagnostic Flow Table B-3 Maintenance in Section 6K.</p> <p>Check oxygen sensor output voltage Refer to DTC P0130 Table in this section.</p> <p>Diagnostic Flow Table B-1 Inspection of ECM and its circuit in Section 6E. EGR system in Section 6E.</p>

SCAN TOOL DATA

As the data values given below are standard values estimated on the basis of values obtained from the normally operating vehicles by using a scan tool, use them as reference values. Even when the vehicle is in good condition, there may be cases where the checked value does not fall within each specified data range. Therefore, judgment as abnormal should not be made by checking with these data alone.

Also, conditions in the below table that can be checked by the scan tool are those detected by ECM and output from ECM as commands and there may be cases where the engine or actuator is not operating (in the condition) as indicated by the scan tool. Be sure to use the timing light to check the ignition timing.

NOTE:

- With the generic scan tool, only star (☆) marked data in the table below can be read.
- The triangle (Δ) marked data in the table below can not be read for vehicle without EGR valve.
- When checking the data with the engine running at idle or racing, be sure to shift M/T gear to the neutral gear position and pull the parking brake fully. Also, if nothing or “no load” is indicated, turn OFF A/C, all electric loads and all the other necessary switches.

	SCAN TOOL DATA	CONDITION		REFERENCE VALUES
☆	FUEL SYSTEM B1 (FUEL SYSTEM STATUS)	At specified idle speed after warming up		CLOSED (closed loop)
☆	CALC LOAD (CALCULATED LOAD VALUE)	At specified idle speed with no load after warming up		3 – 9%
		At 2500 r/min with no load after warming up		12 – 17%
☆	COOLANT TEMP. (ENGINE COOLANT TEMP.)	At specified idle speed after warming up		80 – 100°C, 176 – 212°F
☆	SHORT FT B1 (SHORT TERM FUEL TRIM)	At specified idle speed after warming up		–20 – +20%
☆	LONG FT B1 (LONG TERM FUEL TRIM)	At specified idle speed after warming up		–15 – +15%
☆	MAP (INTAKE MANIFOLD ABSOLUTE PRESSURE)	At specified idle speed with no load after warming up		26 – 43 kPa, 195 – 322 mmHg
☆	ENGINE SPEED	At idling with no load after warming up		Desired idle speed ± 50 r/min
☆	VEHICLE SPEED	At stop		0 km/h, 0 MPH
☆	IGNITION ADVANCE (IGNITION TIMING ADVANCE FOR NO.1 CYLINDER)	At specified idle speed with no load after warming up		6 – 16° BTDC
☆	INTAKE AIR TEMP.	At specified idle speed after warming up		Ambient temp. +35°C (63°F) –5°C (–9°F)
Δ ☆	MAF (MASS AIR FLOW RATE)	At specified idle speed with no load after warming up		1 – 4 gm/sec
☆	THROTTLE POS (THROTTLE POSITION)	Ignition switch ON/engine stopped	Throttle valve fully closed	7 – 18%
			Throttle valve fully open	70 – 90%
☆	O2S B1 S1 (HEATED OXYGEN SENSOR-1)	At specified idle speed after warming up		0.01 – 0.95 V
Δ ☆	O2S B1 S2 (HEATED OXYGEN SENSOR-2)	When engine is running at 2000 r/min. for 3 min or longer after warming up.		0.01 – 0.95 V

SCAN TOOL DATA		CONDITION		REFERENCE VALUES
	DESIRED IDLE (DESIRED IDLE SPEED)	At idling with no load after warming up		750 r/min
	TP SENSOR VOLT (THROTTLE POSITION SENSOR OUTPUT VOLTAGE)	Ignition switch ON/engine stopped	Throttle valve fully closed	More than 0.1 V
			Throttle valve fully open	Less than 4.8 V
	INJ PULSE WIDTH (FUEL INJECTION PULSE WIDTH)	At specified idle speed with no load after warming up		2.0 – 3.6 msec.
		At 2500 r/min with no load after warming up		2.0 – 3.6 msec.
	IAC FLOW DUTY (IDLE AIR CONTROL FLOWDUTY)	At idling with no load after warming up		5 – 25%
	TOTAL FT B1	At specified idle speed after warming up		–35 – +35%
	BATTERY VOLTAGE	Ignition switch ON/engine stop		12 – 15 V
	CANIST PRG DUTY (EVAP CANISTER PURGE FLOW DUTY)	_____		0 – 100%
	CLOSED THROT POS (CLOSED THROTTLE POSITION)	Throttle valve at idle position		ON
		Throttle valve opens larger than idle position		OFF
	FUEL CUT	When engine is at fuel cut condition		ON
		Other than fuel cut condition		OFF
	RADIATOR FAN (RADIATOR FAN CONTROL RELAY)	Ignition switch ON	Engine coolant temp.: 85 °C (185°F) or lower	OFF
			Engine coolant temp.: 90 °C (194°F) or higher	ON

	ELECTRIC LOAD	Ignition switch ON/Headlight, small light and rear window defogger all turned OFF		OFF
		Ignition switch ON/Headlight, small light or rear window defogger turned ON		ON
	A/C SWITCH	Engine running after warming up, A/C not operating		OFF
		Engine running after warming up, A/C operating		ON
	EGR VALVE	At specified idle speed after warming up		0%
Δ	FUEL TANK LEVEL	_____		0 – 100%
	BAROMETRIC PRESS	_____		Display the barometric pressure
	FUEL PUMP	Within 3 seconds after ignition switch ON or engine running		ON
		Engine stop at ignition switch ON.		OFF
	BRAKE SW	Ignition switch ON	Brake pedal is depressing	ON
			Brake pedal is releasing	OFF
	BLOWER FAN	Ignition switch ON	Blower fan switch ON	ON
			Blower fan switch OFF	OFF
	FUEL PRES CONT VALVE (FUEL PRESSURE CONTROL VALVE)	For a while after engine start, when engine coolant temp. 100°C or higher and intake air temp. 65°C or higher		ON
		Other than above		OFF

SCAN TOOL DATA DEFINITIONS

FUEL SYSTEM (FUEL SYSTEM STATUS)

Air/fuel ratio feedback loop status displayed as either open or closed loop. Open indicates that ECM ignores feedback from the exhaust oxygen sensor.

Closed indicates final injection duration is corrected for oxygen sensor feedback.

CALC LOAD (CALCULATED LOAD VALUE, %)

Engine load displayed as a percentage of maximum possible load. Value is calculated mathematically using the formula: actual (current) intake air volume ÷ maximum possible intake air volume x 100%.

COOLANT TEMP.

(ENGINE COOLANT TEMPERATURE, °C, °F)

It is detected by engine coolant temp. sensor

SHORT FT B1 (SHORT TERM FUEL TRIM, %)

Short term fuel trim value represents short term corrections to the air/fuel mixture computation. A value of 0 indicates no correction, a value greater than 0 means an enrichment correction, and a value less than 0 implies an enleanment correction.

LONG FT B1 (LONG TERM FUEL TRIM, %)

Long term fuel trim Value represents long term corrections to the air/fuel mixture computation. A value of 0 indicates no correction, a value greater than 0 means an enrichment correction, and a value less than 0 implies an enleanment correction.

MAP (INTAKE MANIFOLD ABSOLUTE PRESSURE, kPa, inHg)

It is detected by manifold absolute pressure sensor and used (among other things) to compute engine load.

ENGINE SPEED (rpm)

It is computed by reference pulses from crankshaft position sensor.

VEHICLE SPEED (km/h, MPH)

It is computed based on pulse signals from vehicle speed sensor.

IGNITION ADVANCE

(IGNITION TIMING ADVANCE FOR NO.1 CYLINDER, °)

Ignition timing of NO.1 cylinder is commanded by ECM. The actual ignition timing should be checked by using the timing light.

INTAKE AIR TEMP. (°C, °F)

It is detected by intake air temp. sensor and used to determine the amount of air passing into the intake manifold as air density varies with temperature.

MAF (MASS AIR FLOW RATE, gm/s, lb/min)

It represents total mass of air entering intake manifold which is computed based on signals from MAP sensor, IAT sensor, TP sensor, etc.

THROTTLE POS

(ABSOLUTE THROTTLE POSITION, %)

When throttle position sensor is fully closed position, throttle opening is indicated as 0% and 100% full open position.

OXYGEN SENSOR B1 S1

(HEATED OXYGEN SENSOR-1, V)

It indicates output voltage of HO2S-1 installed on exhaust manifold (pre-catalyst).

OXYGEN SENSOR B1 S2

(HEATED OXYGEN SENSOR-2, V)

It indicates output voltage of HO2S-2 installed on exhaust pipe (post-catalyst). It is used to detect catalyst deterioration.

DESIRED IDLE (DESIRED IDLE SPEED, rpm)

The Desired Idle Speed is an ECM internal parameter which indicates the ECM requested idle. If the engine is not running, this number is not valid.

TP SENSOR VOLT (THROTTLE POSITION SENSOR OUTPUT VOLTAGE, V)

The Throttle Position Sensor reading provides throttle valve opening information in the form of voltage.

INJ PULSE WIDTH

(FUEL INJECTION PULSE WIDTH, msec.)

This parameter indicates time of the injector drive (valve opening) pulse which is output from ECM (but injector drive time of NO.1 cylinder for multiport fuel injection).

IAC FLOW DUTY (IDLE AIR (SPEED) CONTROL DUTY, %)

This parameter indicates current flow time rate within a certain set cycle of IAC valve (valve opening rate) which controls the amount of bypass air (idle speed).

TOTAL FUEL TRIM (%)

The value of Total Fuel Trim is obtained by putting values of short Term Fuel Trim and Long Term Fuel Trim together. This value indicates how much correction is necessary to keep the air/fuel mixture stoichiometrical.

BATTERY VOLTAGE (V)

This parameter indicates battery positive voltage inputted from main relay to ECM.

CANIST PURGE DUTY (EVAP CANISTER PURGE FLOW DUTY, %)

This parameter indicates valve ON (valve open) time rate within a certain set cycle of EVAP purge solenoid valve which controls the amount of EVAP purge. 0% means that the purge valve is completely closed while 100% is a fully open valve.

CLOSED THROTTLE POSITION (ON/OFF)

This parameter will read ON when throttle valve is fully closed, or OFF when the throttle is not fully closed.

FUEL CUT (ON/OFF)

ON : Fuel being cut (output signal to injector is stopped)
OFF : Fuel not being cut

RADIATOR FAN (RADIATOR FAN CONTROL RELAY, ON/OFF)

ON : Command for condenser fan control relay operation being output.
OFF : Command for relay operation not being output.

ELECTRIC LOAD (ON/OFF)

ON : Headlight, small light, heater fan or rear window defogger ON signal inputted.
OFF : Above electric loads all turned OFF.

A/C SWITCH (ON/OFF)

ON : Command for A/C operation being output from ECM to A/C amplifier.
OFF : Command for A/C operation not being output.

FUEL TANK LEVEL (%)

This parameter indicates approximate fuel level in the fuel tank. As the detectable range of the fuel level sensor is set as 0 to 100%, however, with some models whose fuel tank capacity is smaller, the indicated fuel level may be only 70% even when the fuel tank is full.

EGR VALVE (%)

This parameter indicates opening rate of EGR valve which controls the amount of EGR flow.

FUEL PRES CONT VALVE (FUEL PRESSURE CONTROL VALVE, ON/OFF)

ON : Fuel pressure control valve closes the passage to intake manifold and open the air passage.
OFF : Fuel pressure control valve closes the air passage and open the passage to intake manifold.

INSPECTION OF ECM AND ITS CIRCUITS

ECM and its circuits can be checked at ECM wiring connectors by measuring resistance.

CAUTION:

ECM cannot be checked by itself. It is strictly prohibited to connect voltmeter or ohmmeter to ECM with connector disconnected from it.

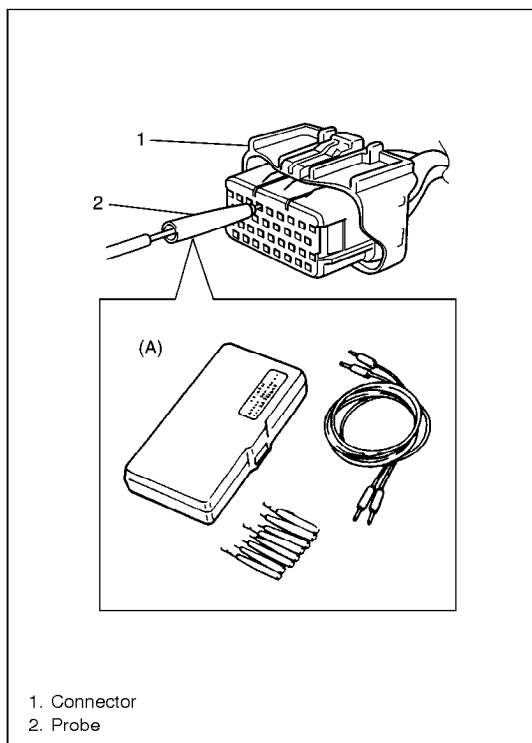

RESISTANCE CHECK

- 1) Disconnect ECM couplers from ECM with ignition switch OFF.

CAUTION:

- Never touch terminals of ECM itself or connect voltmeter or ohmmeter.
- Never insert tester probe from the wire harness side of connector.

- 2) Check resistance between each terminal of couplers disconnected, using a special tool.

Special Tool

(A): 09932-76010

CAUTION:

- Be sure to connect ohmmeter probe from wire terminal side of coupler.
- Be sure to turn OFF ignition switch for this check.
- Resistance in table below represents that when parts temperature is 20°C (68°F).

TERMINALS	CIRCUIT	STANDARD RESISTANCE
C23-6 to L20-2/3	HO2S-1 heater (if equipped)	5 – 6.4 Ω
L20-1 to L20-17	HO2S-2 heater (if equipped)	11.7 – 14.3 Ω
C23-1 to L20-2/3	No.1 injector	10 – 15 Ω
C23-10 to L20-2/3	No.2 injector	10 – 15 Ω
C23-2 to L20-2/3	No.3 injector	10 – 15 Ω
C23-11 to L20-2/3	No.4 injector	10 – 15 Ω
C23-28 to L20-2/3	EGR valve (stepper motor coil 4) (if equipped)	20 – 24 Ω
C23-19 to L20-2/3	EGR valve (stepper motor coil 3) (if equipped)	20 – 24 Ω
C23-27 to L20-2/3	EGR valve (stepper motor coil 2) (if equipped)	20 – 24 Ω
C23-18 to L20-2/3	EGR valve (stepper motor coil 1) (if equipped)	20 – 24 Ω
C23-5 to L20-2/3	EVAP canister purge valve	30 – 34 Ω
L20-32 to L20-17	Fuel pump relay	56 – 146 Ω
C23-4 to L20-2/3	Fuel pressure control valve	37 – 44 Ω
L20-11 to L20-2/3	Radiator fan control relay	56 – 146 Ω
L20-8 to L20-12	Main relay	56 – 146 Ω
C23-17 to Body ground	Ground	Continuity
C23-8 to Body ground	Ground	Continuity
C23-9 to Body ground	Ground	Continuity

COMPONENT LOCATION

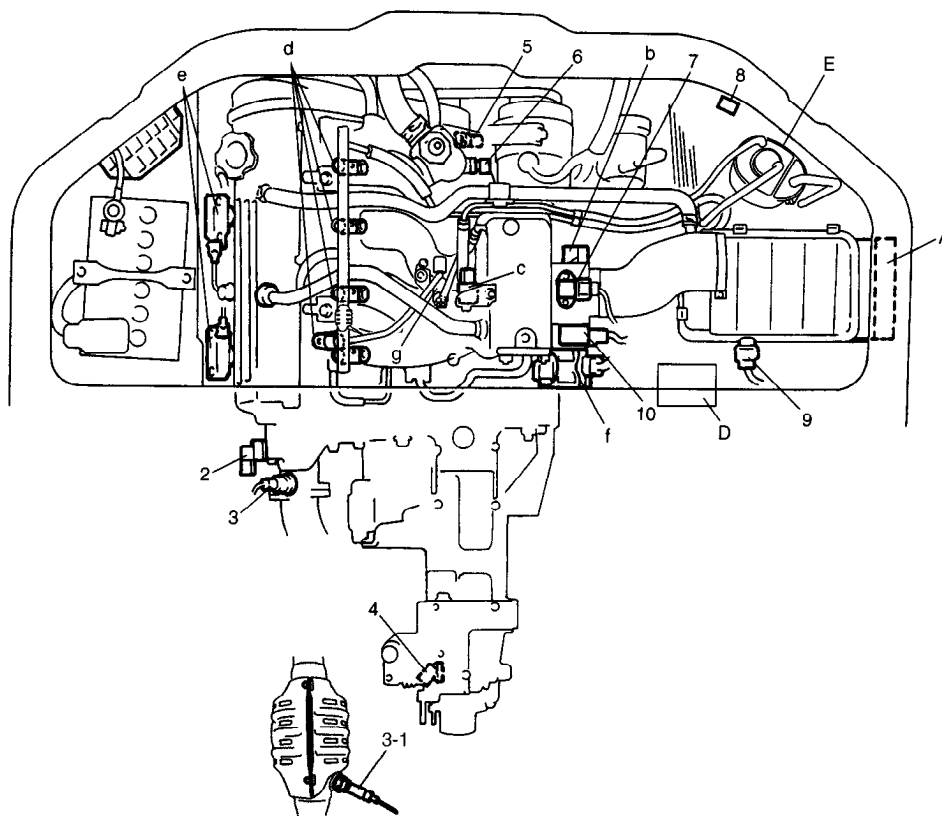
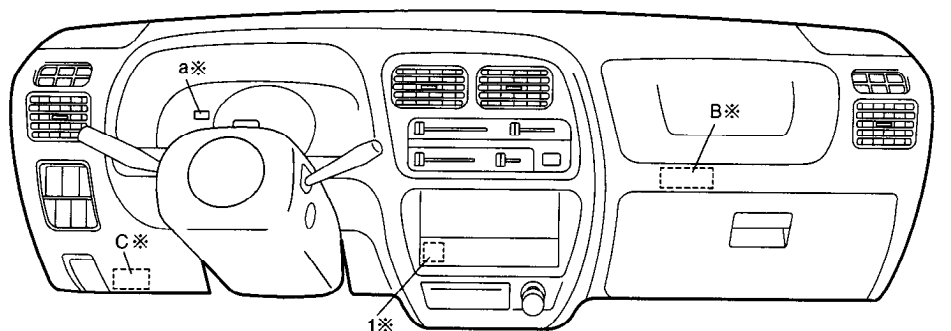

- 1. CO adjusting resistor (if equipped)
- 2. CMP sensor
- 3. HO2S-1 (if equipped)
- 3-1. HO2S-2 (if equipped)
- 4. VSS
- 5. CKP sensor
- 6. ECT sensor
- 7. MAP sensor
- 8. Connector for ignition timing adjusting resistor (if equipped)
- 9. IAT sensor
- 10. TP sensor

- a: MIL
- b: IAC valve
- c: EVAP canister purge valve
- d: Fuel injector
- e: Ignitor coil
- f: EGR valve (if equipped)
- g: Fuel pressure control valve

- A: ECM
- B: A/C control module (if equipped)
- C: DLC
- D: ABS hydraulic unit (if equipped)
- E: EVAP canister

NOTE:
 Above figure shows left-hand steering vehicle.
 For right-hand steering vehicle, parts with (*) are installed at the other side.

TABLE A-1 MALFUNCTION INDICATOR LAMP CIRCUIT CHECK – LAMP DOES NOT COME “ON” AT IGNITION SWITCH ON (BUT ENGINE AT STOP)

CIRCUIT DESCRIPTION

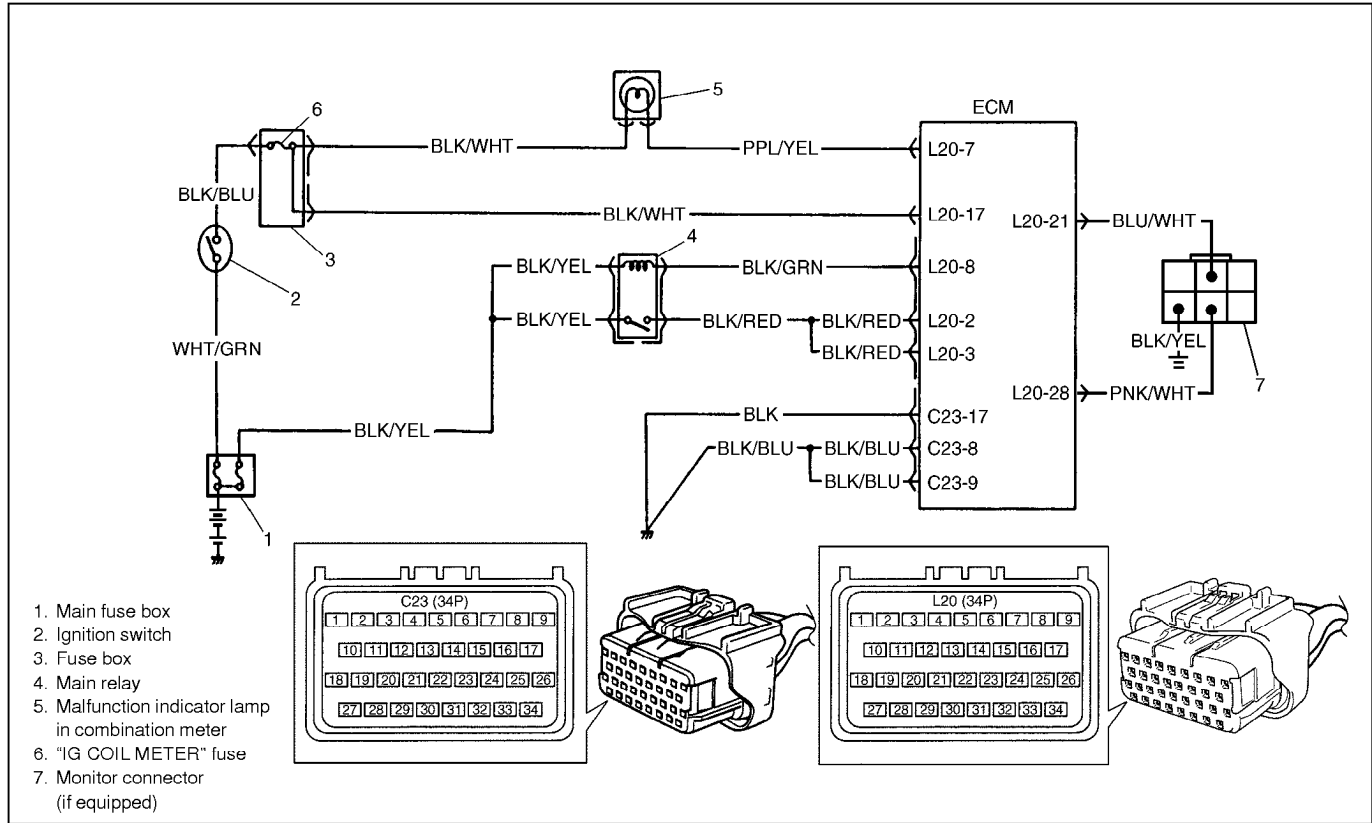

When the ignition switch is turned ON, ECM causes the main relay to turn ON (close the contact point). Then, ECM being supplied with the main power, turns ON the malfunction indicator lamp (MIL). When the engine starts to run and no malfunction is detected in the system, MIL goes OFF but if a malfunction was or is detected, MIL remains ON even when the engine is running.

INSPECTION

STEP	ACTION	YES	NO
1	MIL Power Supply Check 1) Turn ignition switch ON. Do other indicator/warning lights in combination meter come ON?	Go to Step 2.	Main fuse blown, ignition switch malfunction, "BLK/WHT" circuit between "IG COIL METER" fuse and combination meter or poor coupler connection at combination meter.
2	ECM Power and Ground Circuit Check Does engine start?	Go to Step 3.	Go to TABLE A-3 ECM POWER AND GROUND CIRCUIT CHECK. If engine is not cranked, go to DIAGNOSIS in Section 8G.
3	MIL Circuit Check 1) Turn ignition switch OFF and disconnect connectors from ECM. 2) Check for proper connection to ECM at terminal L20-7. 3) If OK, then using service wire, ground terminal L20-7 in connector disconnected. Does MIL turn on at ignition switch ON?	Test switch terminal circuit shorted to ground or "PNK/WHT" wire shorted to ground (vehicle with monitor connector). Substitute a known-good ECM and recheck.	Bulb burned out, "PPL/YEL" wire circuit open or "PNK/WHT" wire shorted to ground.

TABLE A-2 MALFUNCTION INDICATOR LAMP CIRCUIT CHECK – LAMP REMAINS “ON” AFTER ENGINE STARTS

WIRING DIAGRAM/CIRCUIT DESCRIPTION – Refer to table A-1.

INSPECTION

STEP	ACTION	YES	NO
1	Diagnostic Trouble Code (DTC) check 1) Check DTC referring to DTC CHECK section. Is there any DTC(s)?	Go to Step 2 of ENGINE DIAG. FLOW TABLE.	Go to Step 2.
2	DTC check Start engine and recheck DTC while engine running. Is there any DTC(s)?		Go to Step 3.
3	MIL Circuit check 1) Turn OFF ignition switch. 2) Disconnect connectors from ECM. Does MIL turn ON at ignition switch ON?	“PPL/YEL” wire circuit shorted to ground.	Substitute a known-good ECM and recheck.

TABLE A-3 MALFUNCTION INDICATOR LAMP CIRCUIT CHECK – MIL FLASHES AT IGNITION SWITCH ON (VEHICLE WITH MONITOR CONNECTOR)

WIRING DIAGRAM/CIRCUIT DESCRIPTION – Refer to table A-1.

INSPECTION

STEP	ACTION	YES	NO
1	MIL flashing pattern check: 1) With the ignition switch ON position, check MIL flashing pattern. Does MIL flashing pattern indicate DTC (diagnostic trouble code)?	Go to Step 2.	Go to “Diagnosis” in section 8G.
2	Diagnosis switch terminal check: 1) With ignition switch OFF position, disconnect ECM electrical connectors. 2) Check for continuity from L20-21 terminal of ECM connector to ground. Is there continuity?	“BLU/WHT” wire (diagnosis switch terminal) shorted to ground circuit. If OK, substitute a known-good ECM and recheck.	Substitute a known-good ECM and recheck.

TABLE A-4 MALFUNCTION INDICATOR LAMP CIRCUIT CHECK – MIL DOES NOT FLASH, JUST REMAINS ON OR JUST REMAINS OFF EVEN WITH GROUNDING DIAGNOSIS SWITCH TERMINAL (VEHICLE WITH MONITOR CONNECTOR)

WIRING DIAGRAM/CIRCUIT DESCRIPTION – Refer to table A-1.

INSPECTION

STEP	ACTION	YES	NO
1	Diagnosis switch terminal circuit check: 1) With ignition switch OFF position, disconnect ECM electrical connectors. 2) Connect jumper wire from monitor connector "b" terminal to monitor connector "d" terminal. See Fig.1. 3) Check for continuity from L20-21 terminal of ECM connector to ground. Is there continuity?	Go to Step 2.	"BLU/WHT" wire (diagnosis switch terminal), "BLK/YEL" wire of monitor connector open. If OK, substitute a known-good ECM and recheck.
2	Test switch terminal circuit check: 1) Check for continuity from L20-28 terminal of ECM connector to ground. Is there continuity?	"PNK/WHT" wire (test switch terminal) shorted to ground circuit. If OK, substitute a known-good ECM and recheck.	Poor connection of ECM connector. If OK, substitute a known-good ECM and recheck.

Fig. 1 for Step 1

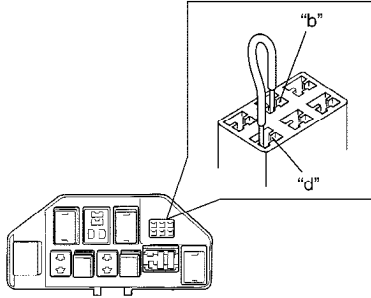
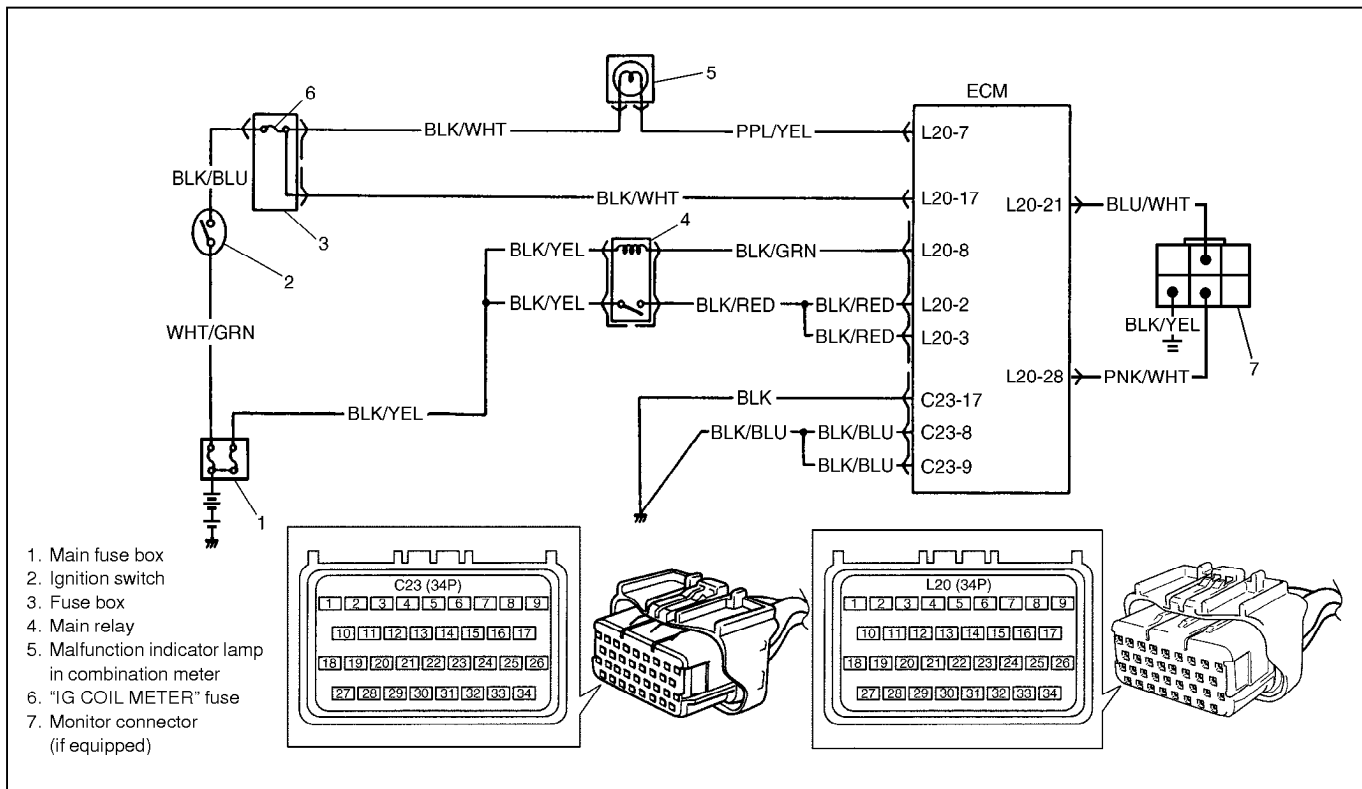

TABLE A-5 ECM POWER AND GROUND CIRCUIT CHECK – MIL DOESN'T LIGHT AT IGNITION SWITCH ON AND ENGINE DOESN'T START THOUGH IT IS CRANKED UP

CIRCUIT DESCRIPTION



When the ignition switch turned ON, the main relay turns ON (the contact point closes) and the main power is supplied to ECM.

INSPECTION

STEP	ACTION	YES	NO
1	Main Relay Operating Sound Check Is operating sound of main relay heard at ignition switch ON?	Go to Step 5.	Go to Step 2.
2	Main Relay Check 1) Turn OFF ignition switch and remove main relay (1). 2) Check for proper connection to main relay (1) at terminal 3 and 4. 3) Check resistance between each two terminals. See Fig. 1 and 2. Between terminals A and B: Infinity Between terminals C and D: 56 – 146 Ω (at 20°C, 68°F) 4) Check that there is continuity between terminals 1 and 2 when battery is connected to terminals 3 and 4. See Fig. 3. Is main relay in good condition?	Go to Step 3.	Replace main relay.
3	Fuse Check Is main fuse (3) in good condition? See Fig. 1.	Go to Step 4.	Check for short in circuits connected to this fuse.
4	ECM Power Circuit Check 1) Turn OFF ignition switch, disconnect connectors from ECM and install main relay. 2) Check for proper connection to ECM at terminals L20-17, L20-8, L20-2 and L20-3. 3) If OK, then measure voltage between terminal L20-8 and ground, L20-17 and ground with ignition switch ON. Is each voltage 10 – 14 V?	Go to Step 5.	"BLK/WHT", "BLK/YEL" or "BLK/RED" circuit open.

STEP	ACTION	YES	NO
5	ECM Power Circuit Check 1) Using service wire, ground terminal L20-8 and measure voltage between terminal L20-2 and ground at ignition switch ON. Is it 10 – 14 V?	Check ground circuits “BLK” and “BLK/BLU” for open. If OK, then substitute a known-good ECM and recheck.	Go to Step 6.
6	Is operating sound of main relay heard in Step 1?	Go to Step 7.	“BLK/RED” or “BLK/BLU” wire open.
7	Main Relay Check 1) Check main relay according to procedure in Step 2. Is main relay in good condition?	“BLK/YEL” or “BLK/RED” wire open.	Replace main relay.

Fig. 1 for Step 2 and 3

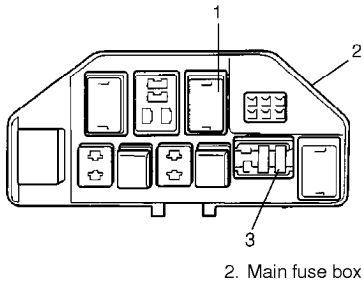

Fig. 2 for Step 2

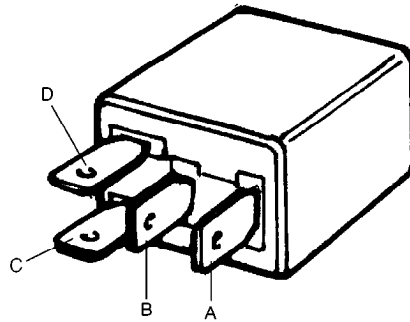
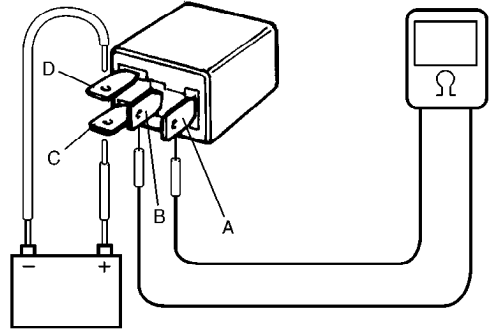
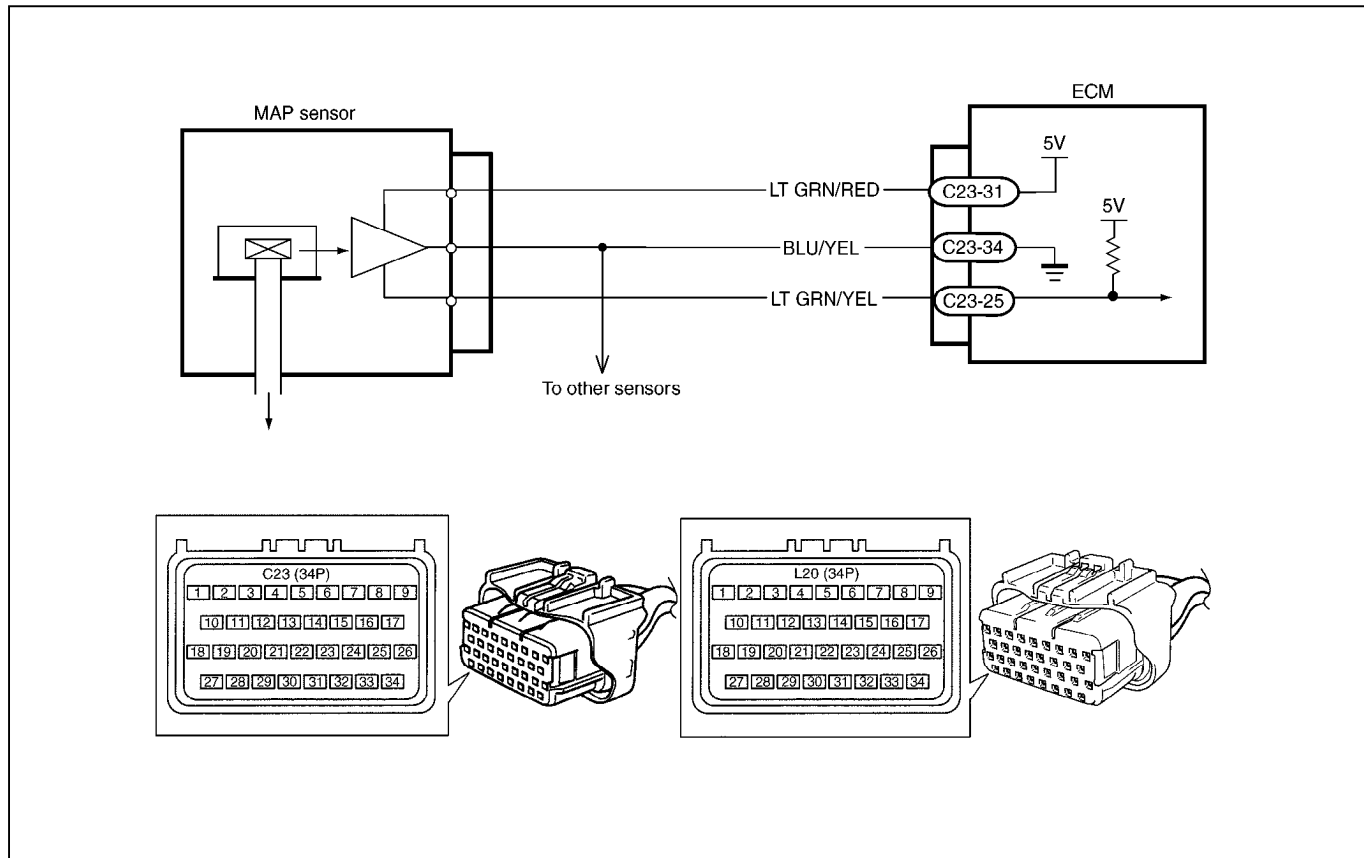

Fig. 3 for Step 2



DTC P0105 MANIFOLD ABSOLUTE PRESSURE (MAP) CIRCUIT (DTC No.11) MALFUNCTION

CIRCUIT DESCRIPTION



DTC DETECTING CONDITION	POSSIBLE CAUSE
<ul style="list-style-type: none"> MAP sensor signal is 0.75 V or lower. (Low pressure – High vacuums – Low voltage) MAP sensor signal is 4.49 V or higher. (High pressure – Low vacuums – High voltage) 	<ul style="list-style-type: none"> “BLU/YEL” circuit open “LT GRN/RED” circuit open or shorted to ground “LT GRN/YEL” circuit open or shorted to ground MAP sensor malfunction ECM malfunction

NOTE:

- When DTC P0105 (No.11), P0110 (No.18), P0115 (No.19) and P0120 (No.13) are indicated together, it is possible that “BLU/YEL” circuit is open.

DTC CONFIRMATION PROCEDURE

- 1) Clear DTC, start engine and keep it at idle for 1 min.
- 2) Select “DTC” mode on scan tool and check DTC.

INSPECTION

STEP	ACTION	YES	NO
1	Was "ENGINE DIAG. FLOW TABLE" performed?	Go to Step 2.	Go to "ENGINE DIAG. FLOW TABLE".
2	Check MAP Sensor and Its Circuit. 1) Connect scan tool to DLC with ignition switch OFF. 2) Turn ignition switch ON. 3) Check intake manifold pressure. See Fig. 1. Is it 146 kPa (43.2 inHg) or 0 kPa (0 inHg)?	Go to Step 3.	Intermittent trouble. Check for intermittent referring to "INTERMITTENT AND POOR CONNECTION" in Section 0A.
3	Check Wire Harness. 1) Disconnect MAP sensor connector with ignition switch OFF. 2) Check for proper connection of MAP sensor at "LT GRN/YEL" and "BLU/YEL" wire terminals. 3) If OK, then with ignition switch ON, check voltage at each of "LT GRN/RED" and "LT GRN/YEL" wire terminals and body ground. See Fig. 1. Is voltage about 4 – 6 V at each terminal?	Go to Step 4.	"LT GRN/RED" wire open or shorted to ground circuit or shorted to power circuit, "LT GRN/YEL" wire open or shorted to ground, poor C23-25 connection or C23-31 connection. If wire and connection are OK, confirm that MAP sensor is normal and then substitute a known-good ECM and recheck. NOTE: When battery voltage is applied to "LT GRN/RED" wire, it is possible that MAP sensor is also faulty.
4	Check MAP sensor referring to "MAP Sensor Inspection" in Section 6E. Is it in good condition?	"LT GRN/RED" wire shorted to "LT GRN/YEL" wire, "BLU/YEL" wire open, poor C23-34 connection. If wire and connection are OK, substitute a known-good ECM and recheck.	Replace MAP sensor.

Fig. 1 for Step 3

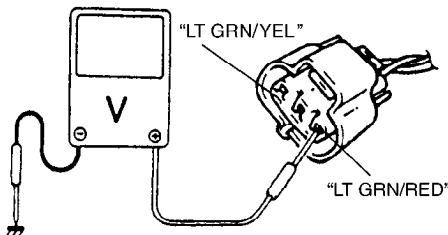

DTC P0110 (DTC No.18) INTAKE AIR TEMP. (IAT) CIRCUIT MALFUNCTION

CIRCUIT DESCRIPTION

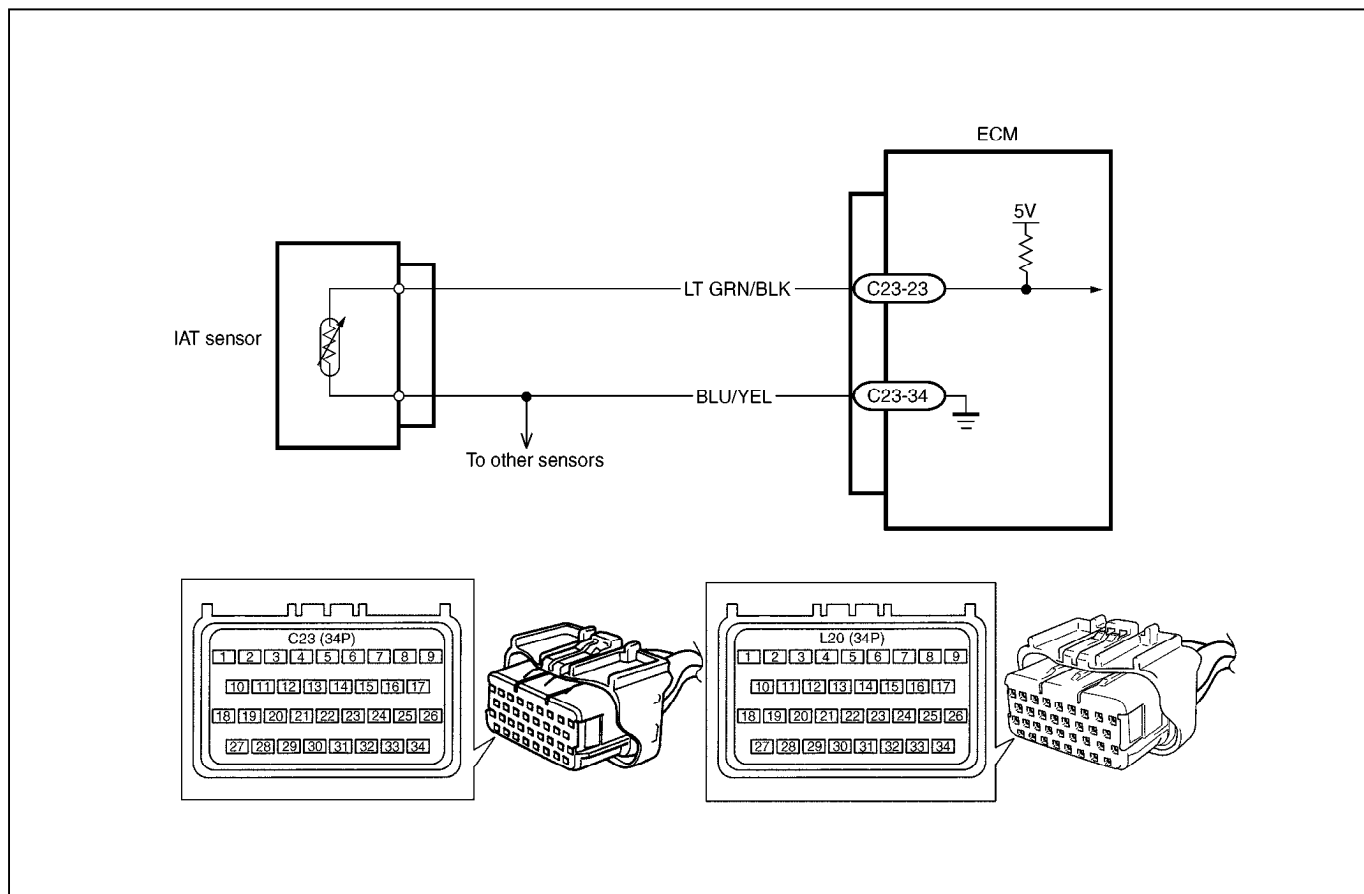

DTC DETECTING CONDITION	POSSIBLE CAUSE
<ul style="list-style-type: none"> ● Low intake air temperature (High voltage-High resistance) ● High intake air temperature (Low voltage-Low resistance) 	<ul style="list-style-type: none"> ● "LT GRN/BLK" circuit open or shorted to power. ● "BLU/YEL" circuit open ● IAT sensor malfunction ● ECM malfunction

NOTE:

- When DTC P0105 (No.11), P0110 (No.18), P0115 (No.19) and P0120 (No.13) are indicated together, it is possible that "BLU/YEL" circuit is open.
- Before inspecting, be sure to check that ambient temperature is higher than -40°C (-40°F).

DTC CONFIRMATION PROCEDURE

- 1) Clear DTC, start engine and keep it at idle for 1 min.
- 2) Select "DTC" mode no scan tool and check DTC.

INSPECTION

STEP	ACTION	YES	NO
1	Was "ENGINE DIAG. FLOW TABLE" performed?	Go to Step 2.	Go to "ENGINE DIAG. FLOW TABLE".
2	Check IAT Sensor and Its Circuit. 1) Connect scan tool to DLC with ignition switch OFF. 2) Turn ignition switch ON. 3) Check intake air temp. displayed on scan tool. Is -40°C (-40°F) or 119°C (246°F) indicated?	Go to Step 3.	Intermittent trouble. Check for intermittent referring to "Intermittent and Poor Connection" in Section 0A.
3	Check Wire Harness. 1) Disconnect IAT sensor connector with ignition switch OFF. 2) Check for proper connection to IAT sensor at "LT GRN/BLK" and "BLU/YEL" wire terminals. 3) If OK, then with ignition switch ON, is voltage applied to "LT GRN/BLK" wire terminal about 4 – 6 V? See Fig. 1.	Go to Step 5.	"LT GRN/BLK" wire open or shorted to power, or poor C23-23 connection. If wire and connection are OK, substitute a known-good ECM and recheck.
4	Does scan tool indicate -40°C (-40°F) at Step 2.	Go to Step 6.	Go to Step 5.
5	Check Wire Harness 1) Check intake air temp. displayed on scan tool with ignition switch ON. Is -40°C (-40°F) indicated?	Replace IAT sensor.	"LT GRN/BLK" wire shorted to ground. If wire is OK, substitute a known-good ECM and recheck.
6	Check Wire Harness. 1) Using service wire, connect IAT sensor connector terminals. 2) Check intake air temp. displayed on scan tool with ignition switch ON. See Fig. 2. Is 119°C (246°F) indicated?	Replace IAT sensor.	"LT GRN/BLK" wire open or poor C23-34 connection. If wire and connection are OK, substitute a known-good ECM and recheck.

Fig. 1 for Step 3

Fig. 2 for Step 4

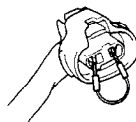
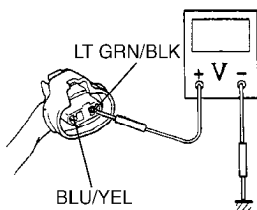

DTC P0115 ENGINE COOLANT TEMPERATURE (ECT) CIRCUIT (DTC No.19) MALFUNCTION

CIRCUIT DESCRIPTION

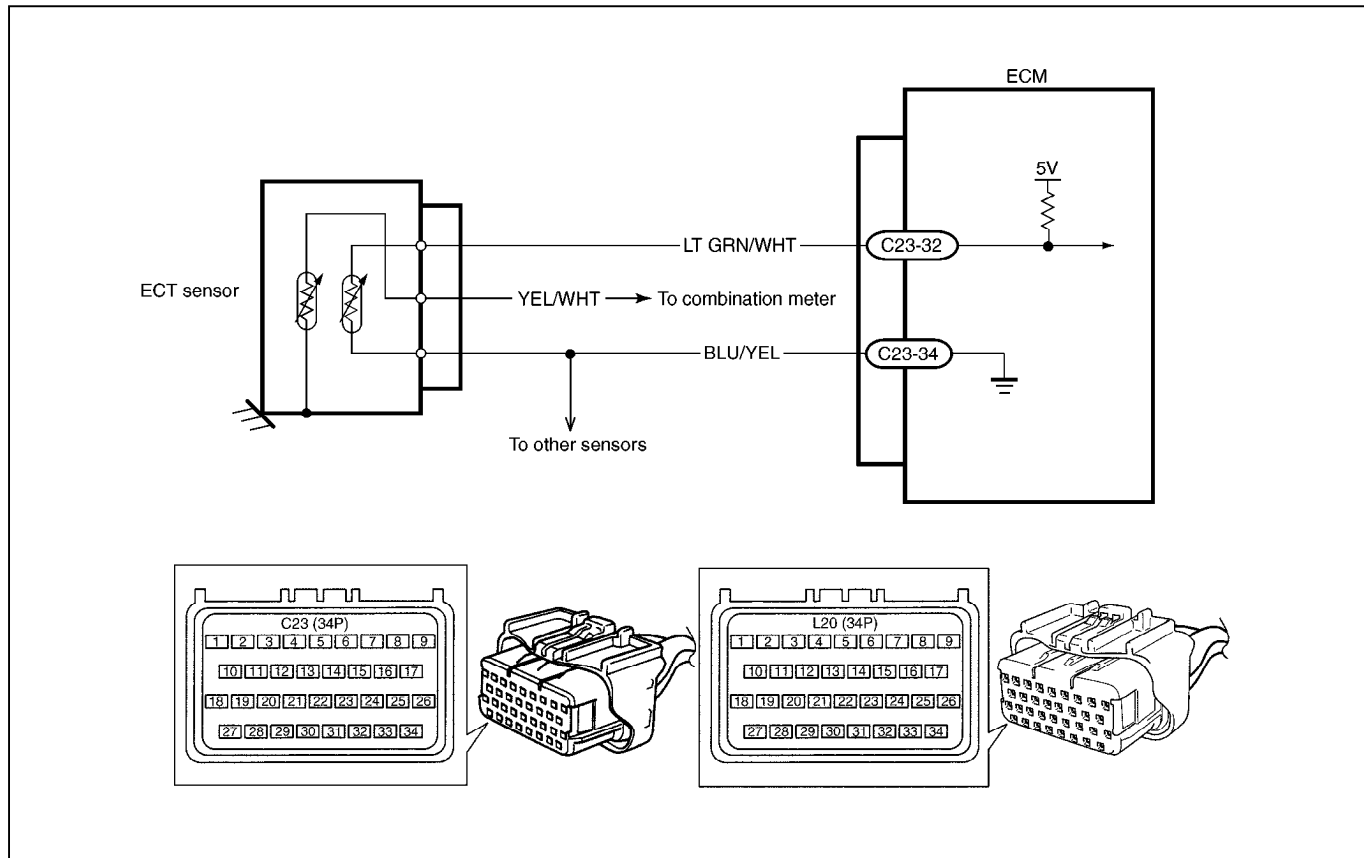

DTC DETECTING CONDITION	POSSIBLE CAUSE
<ul style="list-style-type: none"> ● Low engine coolant temperature (High voltage-High resistance) ● High engine coolant temperature (Low voltage-Low resistance) 	<ul style="list-style-type: none"> ● "LT GRN/WHT" circuit open or shorted to power ● "BLU/YEL" circuit open ● ECT sensor malfunction ● ECM malfunction

NOTE:

- When DTC P0105 (No.11), P0110 (No.18), P0115 (No.19) and P0120 (No.13) are indicated together, it is possible that "BLU/YEL" circuit is open.
- Before inspecting, be sure to check that coolant temp. meter in combination meter indicates normal operating temperature (Engine is not overheating).

DTC CONFIRMATION PROCEDURE

- 1) Clear DTC, start engine and keep it at idle for 1 min.
- 2) Select "DTC" mode on scan tool and check DTC.

INSPECTION

STEP	ACTION	YES	NO
1	Was "ENGINE DIAG. FLOW TABLE" performed?	Go to Step 2.	Go to "ENGINE DIAG. FLOW TABLE".
2	Check ECT Sensor and Its Circuit. 1) Connect scan tool with ignition switch OFF. 2) Turn ignition switch ON. 3) Check engine coolant temp. displayed on scan tool. See Fig. 1. Is -40°C (-40°F) or 119°C (246°F) indicated?	Go to Step 3.	Intermittent trouble. Check for intermittent referring to "Intermittent and Poor Connection" in Section 0 A.
3	Check Wire Harness. 1) Disconnect ECT sensor connector. 2) Check engine coolant temp. displayed on scan tool. Is -40°C (-40°F) indicated?	Replace ECT sensor.	"LT GRN/WHT" wire shorted to ground. If wire is OK, substitute a known-good ECM and recheck.
4	Does scan tool indicate -40°C (-40°F) at Step 2.	Go to Step 6.	Go to Step 5.
5	Check Wire Harness. 1) Disconnect ECT sensor connector with ignition switch OFF. 2) Check for proper connection to ECT sensor at "BLU/YEL" and "LT GRN/WHT" wire terminals. 3) If OK, then with ignition switch ON, is voltage applied to "LT GRN/WHT" wire terminal about 4 – 6 V? See Fig. 1.	Go to Step 4.	"LT GRN/WHT" wire open or shorted to power, or poor C23-32 connection. If wire and connection are OK, substitute a known-good ECM and recheck.
6	Check Wire Harness. 1) Using service wire, connect ECT sensor connector terminals. See Fig. 2. 2) Turn ignition switch ON and check engine coolant temp. displayed on scan tool. Is 119°C (246°F) indicated?	Replace ECT sensor.	"BLU/YEL" wire open or poor C23-34 connection. If wire and connection are OK, substitute a known-good ECM and recheck.

Fig. 1 for Step 5

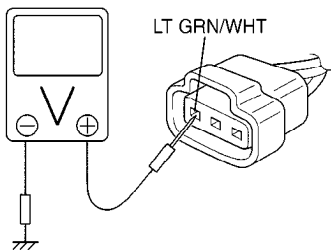
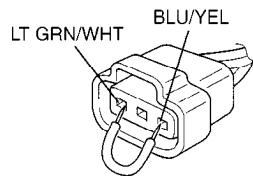
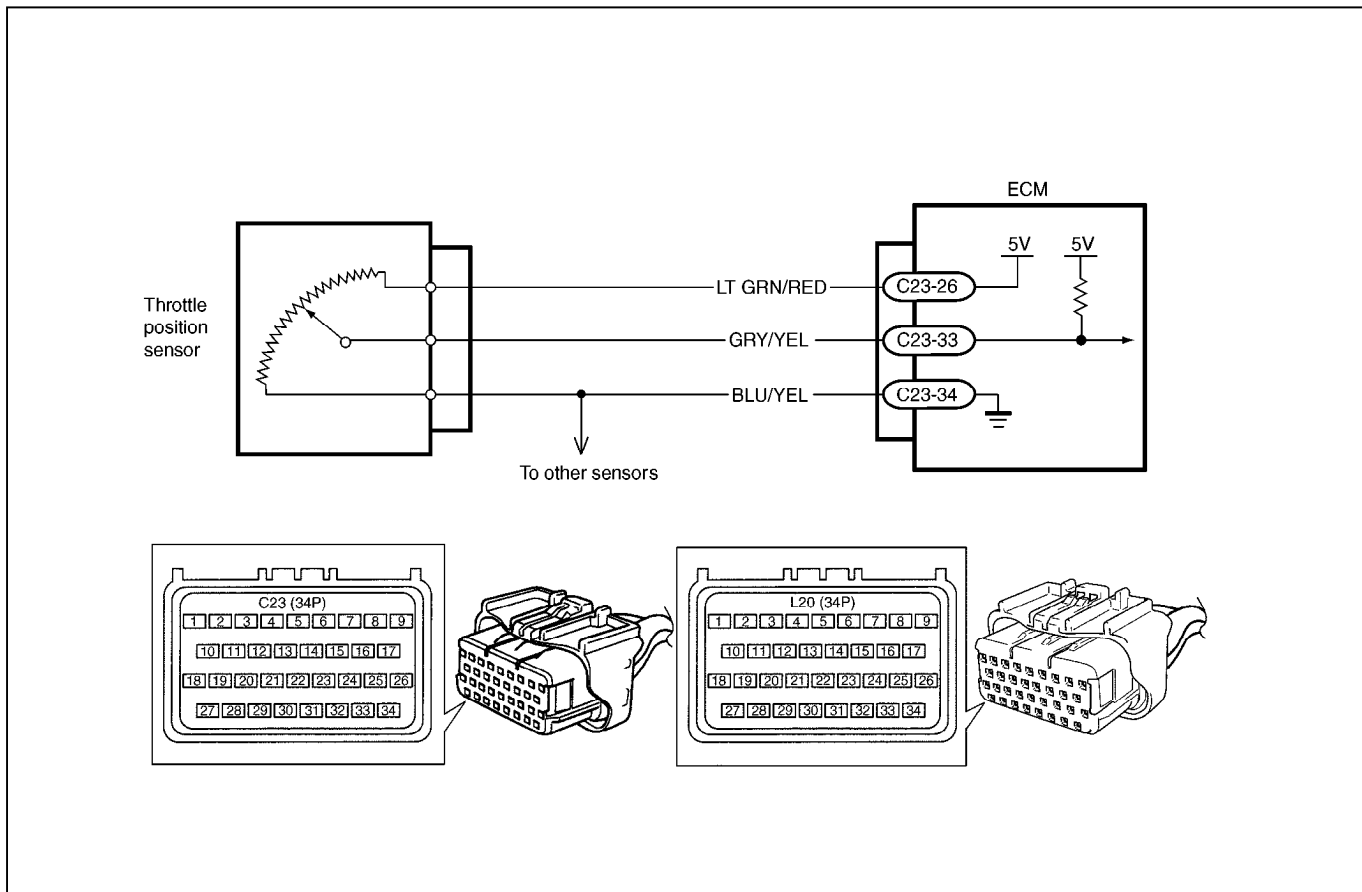

Fig. 2 for Step 6



DTC P0120 (DTC No.13) THROTTLE POSITION CIRCUIT MALFUNCTION

CIRCUIT DESCRIPTION



DTC DETECTING CONDITION	POSSIBLE CAUSE
<ul style="list-style-type: none"> ● Signal voltage high ● Signal voltage low 	<ul style="list-style-type: none"> ● “BLU/YEL” circuit open ● “GRY/YEL” circuit open or shorted to ground ● “LT GRN/RED” circuit open or shorted to power or ground ● TP sensor malfunction ● ECM malfunction

NOTE:

When DTC P0105 (No.11), P0110 (No.18), P0115 (No.19) and P0120 (No.13) are indicated together, it is possible that “BLU/YEL” circuit is open.

DTC CONFIRMATION PROCEDURE

- 1) Clear DTC, start engine and keep it at idle for 1 min.
- 2) Select “DTC” mode on scan tool and check DTC.

INSPECTION

STEP	ACTION	YES	NO
1	Was "ENGINE DIAG. FLOW TABLE" performed?	Go to Step 2.	Go to "ENGINE DIAG. FLOW TABLE".
2	Check TP Sensor and Its Circuit. 1) Connect scan tool to DLC with ignition switch OFF and then turn ignition switch ON. 2) Check throttle valve opening percentage displayed on scan tool. Is it displayed 0% or 100%?	Go to Step 3.	Intermittent trouble. Check for intermittent referring to "Intermittent and Poor Connection" in Section 0 A.
3	Check Wire Harness. 1) Disconnect connector from TP sensor with ignition switch OFF. 2) Check for proper connection to TP sensor at "LT GRN/RED", "GRY/YEL" and "BLU/YEL" wire terminal. 3) If OK, then with ignition switch ON, check voltage at each of "LT GRN/RED" and "GRY/YEL" wire terminals and body ground. See Fig. 1. Is voltage about 4 – 6 V at each terminal?	Go to Step 4.	"LT GRN/YEL" wire open, "LT GRN/YEL" wire shorted to ground circuit or power circuit or "BLU/YEL" wire, "GRY/YEL" wire open or shorted to ground circuit or poor C23-26 or C23-33 connection. If wire and connection are OK, substitute a known-good ECM and recheck.
4	Check TP Sensor. 1) Check resistance between terminals of TP sensor. See Fig. 2. Between 1 and 2: 2.5 – 6.0 kΩ Between 1 and 3: Varying according to throttle valve opening (0.02 – 6.0 kΩ) Are measured values within specifications?	"BLU/YEL" wire open or poor C23-34 connection. If wire and connection are OK, substitute a known-good ECM and recheck.	Replace TP sensor.

Fig. 1 for Step 3

Fig. 2 for Step 4

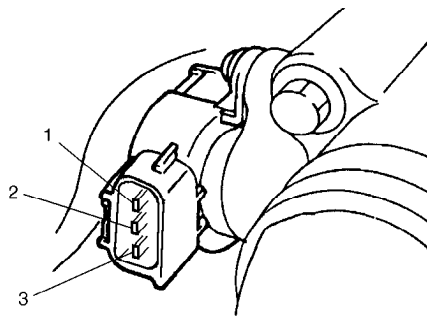
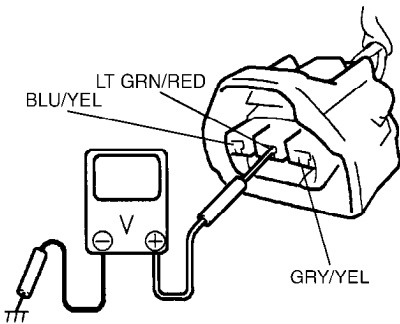

DTC P0121 THROTTLE POSITION CIRCUIT RANGE/PERFORMANCE PROBLEM

WIRING DIAGRAM – Refer to DTC P0120 section.

CIRCUIT DESCRIPTION

DTC DETECTING CONDITION	POSSIBLE CAUSE
<ul style="list-style-type: none"> ● After engine warmed up. ● Difference between actual throttle opening (detected from TP sensor) and opening calculated by ECM (Obtained on the basis of engine speed and intake manifold pressure) is larger than specified value. <p>※ 2 driving cycle detection logic, continuous monitoring</p>	<ul style="list-style-type: none"> ● TP sensor malfunction ● High resistance in the circuit ● ECM malfunction

DTC CONFIRMATION PROCEDURE

WARNING:

- **When performing a road test, select a place where there is no traffic or possibility of a traffic accident and be very careful during testing to avoid occurrence of an accident.**
- **Road test should be carried out with 2 persons, a driver and a tester, on a level road.**

- 1) Turn ignition switch OFF. Clear DTC with ignition switch ON, check vehicle and environmental condition for:
 - Altitude (barometric pressure): 2400 m, 8000 ft or less (560 mmHg, 75 kPa or more)
 - Ambient temp.: –10°C, 14°F or higher
 - Intake air temp.: 70°C, 158°F or lower
 - Engine coolant temp.: 70°C, 158°F or higher
- 2) Warm up engine to normal operating temperature.
- 3) Increase vehicle speed to 30 – 40 mph, 50 – 60 km/h in 3rd gear and hold throttle valve at that opening position for 1 min.
- 4) Stop vehicle.
- 5) Check DTC in “DTC” mode and pending DTC in “PENDING DTC” mode.

INSPECTION

STEP	ACTION	YES	NO
1	Was “ENGINE DIAG. FLOW TABLE” performed?	Go to Step 2.	Go to “ENGINE DIAG. FLOW TABLE”.
2	Check TP Sensor and Its Circuit. 1) Turn ignition switch OFF and connect SUZUKI scan tool to DLC. 2) Turn ignition switch ON and check TP sensor output voltage when throttle valve is at idle position and fully opened. See Fig. 1.	If OK, substitute a known-good ECM and recheck.	Go to Step 3.
3	Check TP Sensor. 1) Turn ignition switch OFF. 2) Disconnect TP sensor connector. 3) Check for proper connection to TP sensor at each terminal. 4) If OK, then measure resistance between terminals and check if each measured value is as specified below. See Fig. 2. Between 1 and 2: 2.5 – 6.0 kΩ Between 1 and 3: 0.02 Ω – 6.0 kΩ, varying according to throttle valve opening. Are measured values as specified?	High resistance in “LT GRN/RED”, “GRY/YEL” or “BLU/YEL” circuit. If wire and connection are OK, substitute a known-good ECM and recheck.	Replace TP sensor.

Fig. 1 for Step 2

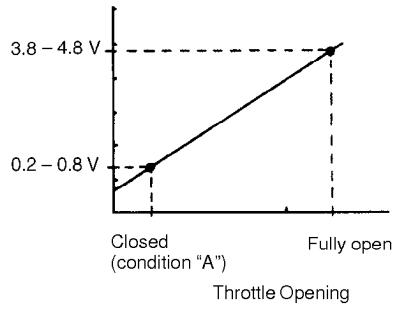
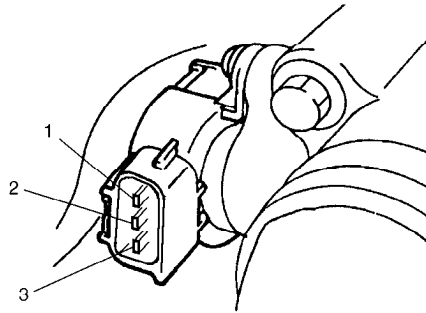
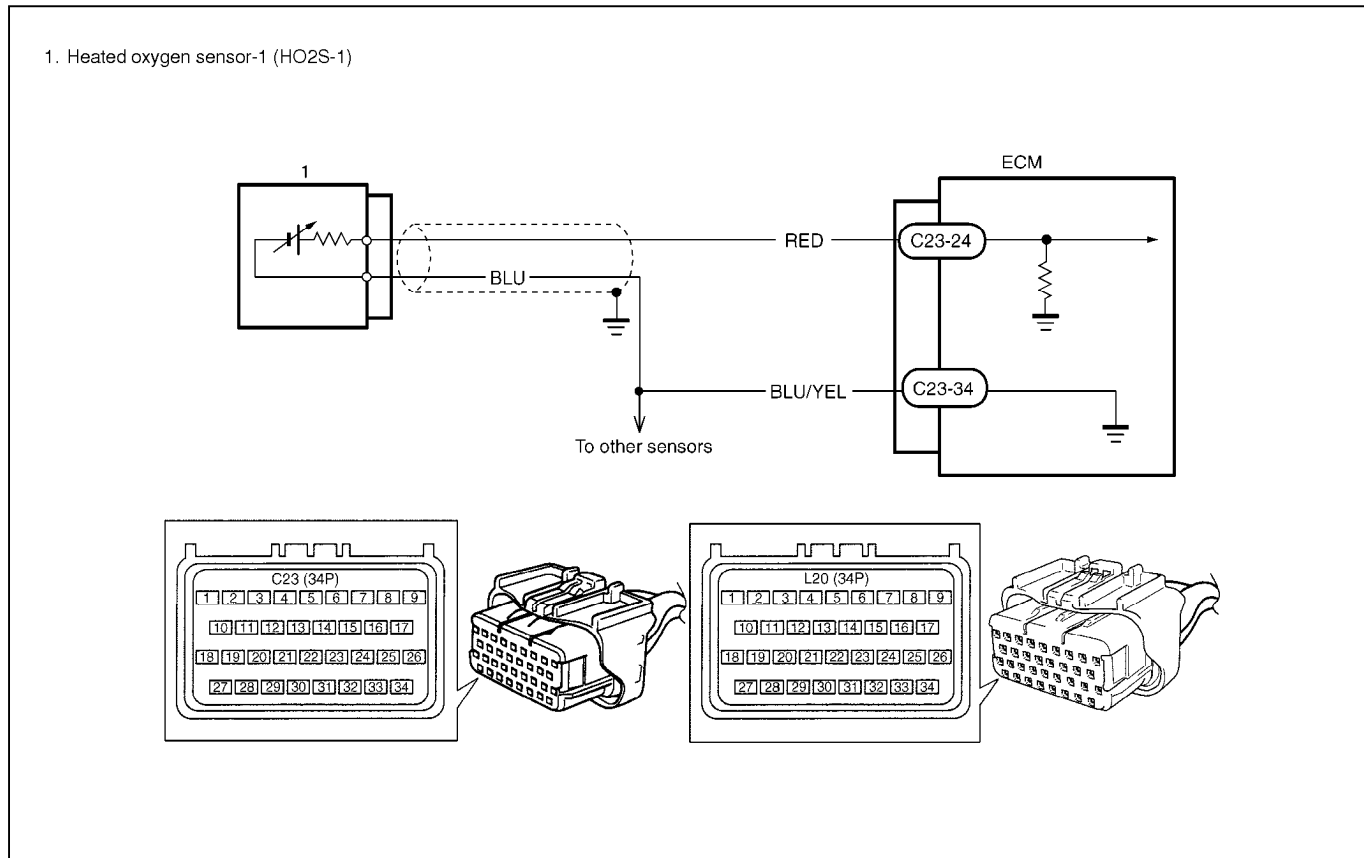

Fig. 2 for Step 3



DTC P0130 HEATED OXYGEN SENSOR (HO2S) CIRCUIT MALFUNCTION (SENSOR-1)

CIRCUIT DESCRIPTION



DTC DETECTING CONDITION	POSSIBLE CAUSE
<ul style="list-style-type: none"> When running at idle speed after engine warmed up and running at specified vehicle speed, HO2S-1 output voltage does not go below 0.3 V or over 0.6 V. * 2 driving cycle detection logic, Monitoring once/1 driving. 	<ul style="list-style-type: none"> Heated oxygen sensor-1 malfunction "BLU/YEL", "BLU" or "RED" circuit open (poor connection) or short

DTC CONFIRMATION PROCEDURE

WARNING:

- When performing a road test, select a place where there is no traffic or possibility of a traffic accident and be very careful during testing to avoid occurrence of an accident.
- Road test should be carried out with 2 persons, a driver and a tester.

- Turn ignition switch OFF. Clear DTC with ignition switch ON, check vehicle and environmental condition for:
 - Altitude (barometric pressure): 2400 m, 8000 ft or less (560 mmHg, 75 kPa or more)
 - Ambient temp.: -10°C , 14°F or higher
 - Intake air temp.: 70°C , 158°F or lower
- Warm up engine to normal operating temperature.
- Drive vehicle at 30 – 40 mph, 50 – 60 km/h for 2 min.
- Stop vehicle and run engine at idle for 2 min.
- Check DTC in "DTC" mode and pending DTC in "PENDING DTC" mode.

INSPECTION

STEP	ACTION	YES	NO
1	Was "ENGINE DIAG. FLOW TABLE" performed?	Go to Step 2.	Go to "ENGINE DIAG. FLOW TABLE".
2	Is there DTC(s) other than HO2S-1 (DTC P0130)?	Go to applicable DTC Diag. Flow Table.	Go to Step 3.
3	1) Connect scan tool to DLC with ignition switch OFF. 2) Warm up engine to normal operating temperature and keep it at 2000 r/min. for 60 sec. 3) Repeat racing engine (Repeat depressing accelerator pedal 5 to 6 times continuously and take foot off from pedal to enrich and enlean A/F mixture). See Fig. 1. Does HO2S-1 output voltage deflect between 0.3 V and over 0.6 V repeatedly?	Intermittent trouble. Check for intermittent referring to "Intermittent and Poor Connection" in Section 0A.	Check "RED", "BLU" and "BLU/YEL" wires for open and short, and connections for poor connection. If wires and connections are OK, replace HO2S-1.

Fig. 1 for Step 3

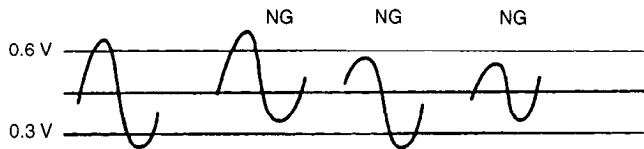

DTC P0133 HEATED OXYGEN SENSOR (HO2S) CIRCUIT SLOW RESPONSE (SENSOR-1)

WIRING DIAGRAM – Refer to DTC P0130 section.

CIRCUIT DESCRIPTION

DTC DETECTING CONDITION	POSSIBLE CAUSE
<ul style="list-style-type: none"> When running at specified idle speed after engine warmed up and running at specified vehicle speed, response time (time to change from lean to rich or from rich to lean) of HO2S-1 output voltage is about 1 sec. at minimum or average time of 1 cycle is 5 sec. at minimum. See. Fig. 1 * 2 driving cycle detection logic, Monitoring once/1 driving. 	<ul style="list-style-type: none"> Heated oxygen sensor-1 malfunction

Fig. 1

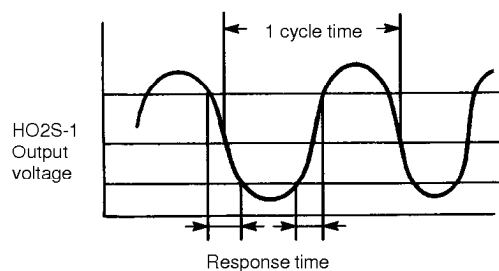

DTC CONFIRMATION PROCEDURE – Refer to DTC P0130 section.

INSPECTION

STEP	ACTION	YES	NO
1	Was "ENGINE DIAG. FLOW TABLE" performed?	Go to Step 2.	Go to "ENGINE DIAG. FLOW TABLE".
2	Is there DTC(s) other than HO2S-1 (DTC P0133)?	Go to applicable DTC Diag. Flow Table.	Replace HO2S-1.

DTC P0134 (No.14) HEATED OXYGEN SENSOR (HO2S) CIRCUIT NO ACTIVITY DETECTED (SENSOR-1)

WIRING DIAGRAM/CIRCUIT DESCRIPTION – Refer to DTC P0130 section.

DTC DETECTING CONDITION	POSSIBLE CAUSE
<ul style="list-style-type: none"> ● Engine warmed up. ● While running under other than high load and high engine speed conditions or at specified idle speed (engine is closed loop condition), HO2S-1 output voltage is high or low continuously. <p>※ 2 driving cycle detection logic, Continuous monitoring.</p>	<ul style="list-style-type: none"> ● “RED” or “BLU/YEL” circuit open or short ● Heated oxygen sensor malfunction ● Fuel system malfunction ● Exhaust gas leakage

DTC CONFIRMATION PROCEDURE – Refer to DTC P0130 section.

INSPECTION

STEP	ACTION	YES	NO
1	Was “ENGINE DIAG. FLOW TABLE” performed?	Go to Step 2.	Go to “ENGINE DIAG. FLOW TABLE”.
2	Is there DTC(s) other than Fuel system (DTC P0171/P0172) and HO2S-1 (DTC P0134)?	Go to applicable DTC Diag. Flow Table.	Go to Step 3.
3	<p>Check HO2S-1 and Its Circuit.</p> <p>1) Connect scan tool to DLC with ignition switch OFF.</p> <p>2) Warm up engine to normal operating temperature and keep it at 2000 r/min. for 60 sec.</p> <p>3) Repeat racing engine (Repeat depressing accelerator pedal 5 to 6 times continuously and take foot off from pedal to enrich and enlean A/F mixture).</p> <p>Does HO2S-1 output voltage deflect between 0.3 V and over 0.6 V repeatedly?</p>	Go to DTC P0171 and P0172 Diag. Flow Table (Fuel System Check).	Check “RED” and “BLU/YEL” wires for open and short, and connections for poor connection. If wires and connections are OK, replace HO2S-1.

DTC P0135 HEATED OXYGEN SENSOR (HO2S) HEATER CIRCUIT MALFUNCTION (SENSOR-1)

CIRCUIT DESCRIPTION

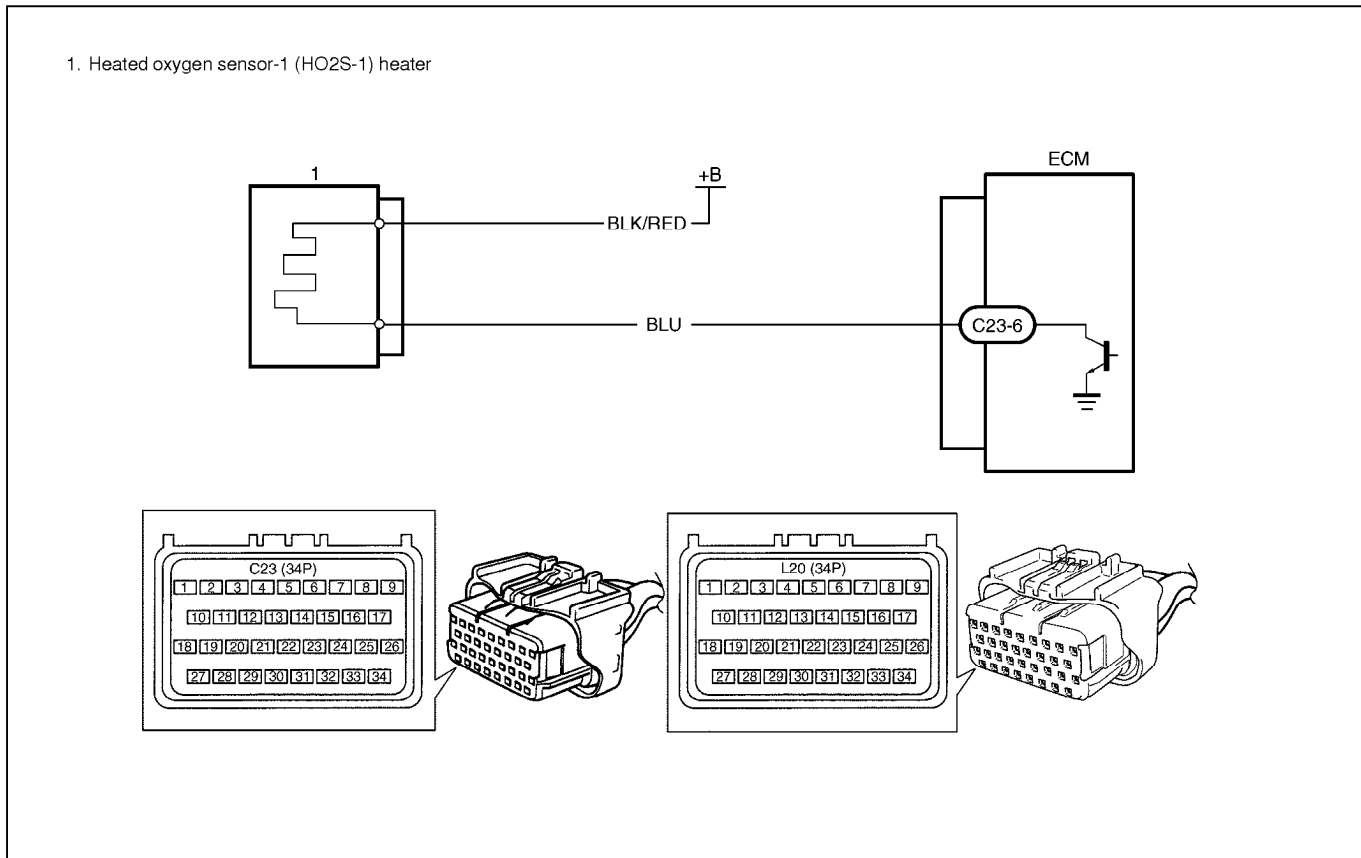

DTC DETECTING CONDITION	POSSIBLE CAUSE
<p>DTC will set when A or B condition is met.</p> <p>A:</p> <ul style="list-style-type: none"> ● Low voltage at terminal C23-6 when engine is running at high load. <p>B:</p> <ul style="list-style-type: none"> ● High voltage at terminal C23-6 when engine is running under condition other than above. <p>* 2 driving cycle detection logic, Continuous monitoring.</p>	<ul style="list-style-type: none"> ● HO2S-1 heater circuit open or shorted to ground ● ECM malfunction

DTC CONFIRMATION PROCEDURE

WARNING:

- When performing a road test, select a place where there is no traffic or possibility of a traffic accident and be very careful during testing to avoid occurrence of an accident.
- Road test should be carried out with 2 persons, a driver and a tester.

- 1) Turn ignition switch OFF.
- 2) Clear DTC with ignition switch ON, start engine and keep it at idle for 1 min.
- 3) Start vehicle and depress accelerator pedal fully for 5 sec. or longer.
- 4) Stop vehicle.
- 5) Check DTC in "DTC" mode and pending DTC in "PENDING DTC" mode.

INSPECTION

STEP	ACTION	YES	NO
1	Was "ENGINE DIAG. FLOW TABLE" performed?	Go to Step 2.	Go to "ENGINE DIAG. FLOW TABLE".
2	Check HO2S-1 Heater Circuit. 1) Disconnect HO2S-1 electrical connector and ECM electrical connectors with ignition switch OFF. 2) Check "BLK/RED" and "BLU" wires for open or short. Are "BLK/RED" and "BLU" wires in good condition?	Intermittent trouble Check for intermittent referring to "Intermittent and Poor Connection" in Section 0A.	Go to Step 3.
3	Check Heater of Sensor-1. 1) Disconnect HO2S-1 coupler with ignition switch OFF. 2) Check for proper connection to HO2S-1 at "BLK/RED" and "BLU" wire terminals. 3) If OK, then check heater resistance. See Fig. 1. Is it 5 – 6.4 Ω at 20°C, 68°F?	"BLU" wire open or shorted to ground or poor connection at C23-6. If wire and connection are OK, substitute a known-good ECM and recheck.	Replace HO2S-1.

Fig. 1 for Step 3

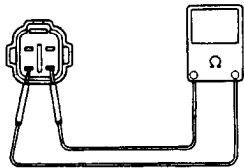

DTC P0136 HEATED OXYGEN SENSOR (HO2S) CIRCUIT MALFUNCTION (SENSOR-2)

CIRCUIT DESCRIPTION

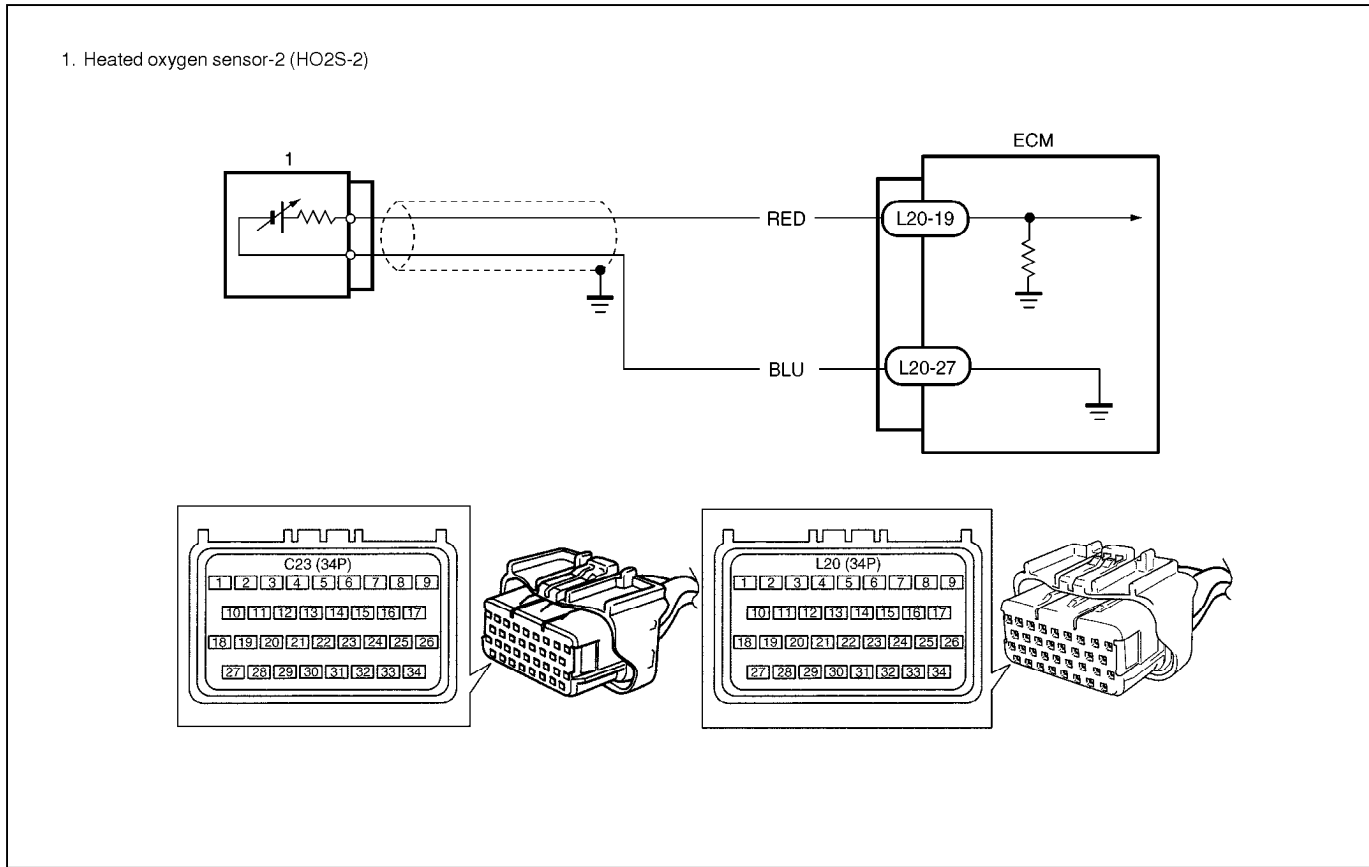

DTC DETECTING CONDITION	POSSIBLE CAUSE
Engine is warmed up and HO2S-2 voltage is 4.5 V or more. (circuit open) ※ 2 driving cycle detection logic, monitoring once/1 driving.	<ul style="list-style-type: none"> ● Exhaust gas leakage ● "RED" or "BLU" circuit open or short ● Heated oxygen sensor-2 malfunction ● Fuel system malfunction

DTC CONFIRMATION PROCEDURE**WARNING:**

- When performing a road test, select a place where there is no traffic or possibility of a traffic accident and be very careful during testing to avoid occurrence of an accident.
- Road test should be carried out with 2 persons, a driver and a tester, on a level road.

1) Turn ignition switch OFF.

Clear DTC with ignition switch ON, check vehicle and environmental condition for:

- Altitude (barometric pressure): 2400 m, 8000 ft or less (560 mmHg, 75 kPa or more)
- Ambient temp.: -10°C , 14°F or higher
- Intake air temp.: 70°C , 158°F or lower
- No exhaust gas leakage and loose connection

2) Warm up engine to normal operating temperature.

3) Drive vehicle under usual driving condition for 5 min. and check HO2S-2 output voltage and “short term fuel trim” with “Data List” mode on scan tool, and write it down.

4) Stop vehicle (don't turn ignition switch OFF).

5) Increase vehicle speed to higher than 20 mph, 32 km/h and then stop vehicle.

6) Repeat above steps 5) 4 times.

7) Increase vehicle speed to about 50 mph (80 km/h) in 3rd gear.

8) Release accelerator pedal and with engine brake applied, keep vehicle coasting (fuel cut condition) for 10sec. or more.

9) Stop vehicle (don't turn ignition switch OFF) and run engine at idle for 2 min.

After this step 9), if “Oxygen Sensor Monitoring TEST COMPLETED” is displayed in “READINESS TESTS” mode and DTC is not displayed in “DTC” mode, confirmation test is completed.

If “TEST NOT COMPLTD” is still being displayed, proceed to next step 10).

10) Drive vehicle under usual driving condition for 10 min. (or vehicle is at a stop and run engine at idle for 10 min. or longer)

11) Stop vehicle (don't turn ignition switch OFF). Confirm test results according to “Test Result Confirmation Flow Table” in “DTC CONFIRMATION PROCEDURE” of DTC P0420.

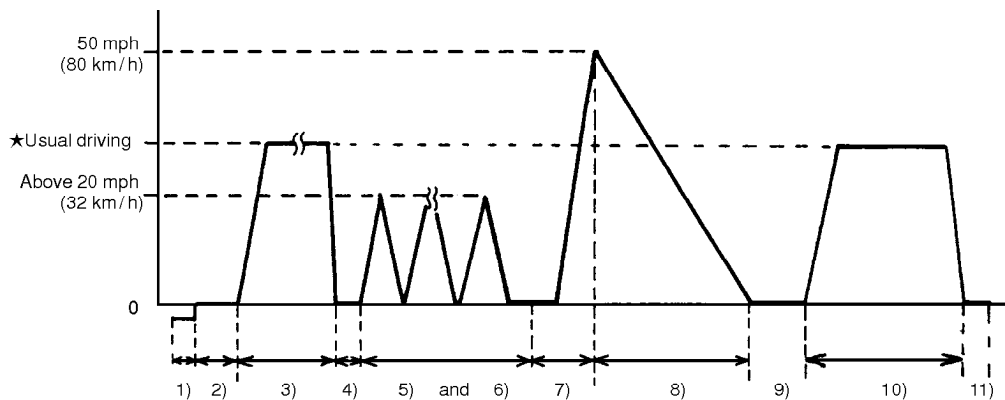

★Usual driving: Driving at 30 – 40 mph, 50 – 60 km/h including short stop according to traffic signal. (under driving condition other than high-load, high-engine speed, rapid accelerating and decelerating)

INSPECTION

STEP	ACTION	YES	NO
1	Was "ENGINE DIAG. FLOW TABLE" performed?	Go to Step 2.	Go to "ENGINE DIAG. FLOW TABLE".
2	Check exhaust system for leakage, loose connection and damage. Is it good condition?	Go to Step 3.	Repair or replace.
3	Check HO2S-2 and Its Circuit. Was HO2S-2 output voltage indicated on scan tool in step 3) of DTC confirmation test less than 1.275 V?	Go to Step 4.	"BLU" or "RED" circuit open or HO2S-2 malfunction.
4	Check Short Term Fuel Trim. Did short term fuel trim vary within -20 - +20% range in step 3) of DTC confirmation test?	Check "RED" and "BLU" wire for open and short, and connection for poor connection. If wire and connection are OK, replace HO2S-2.	Check fuel system. Go to DTC P0171/P0172 Diag. Flow Table.

DTC P0141 HEATED OXYGEN SENSOR (HO2S) HEATER CIRCUIT MALFUNCTION (SENSOR-2)

CIRCUIT DESCRIPTION

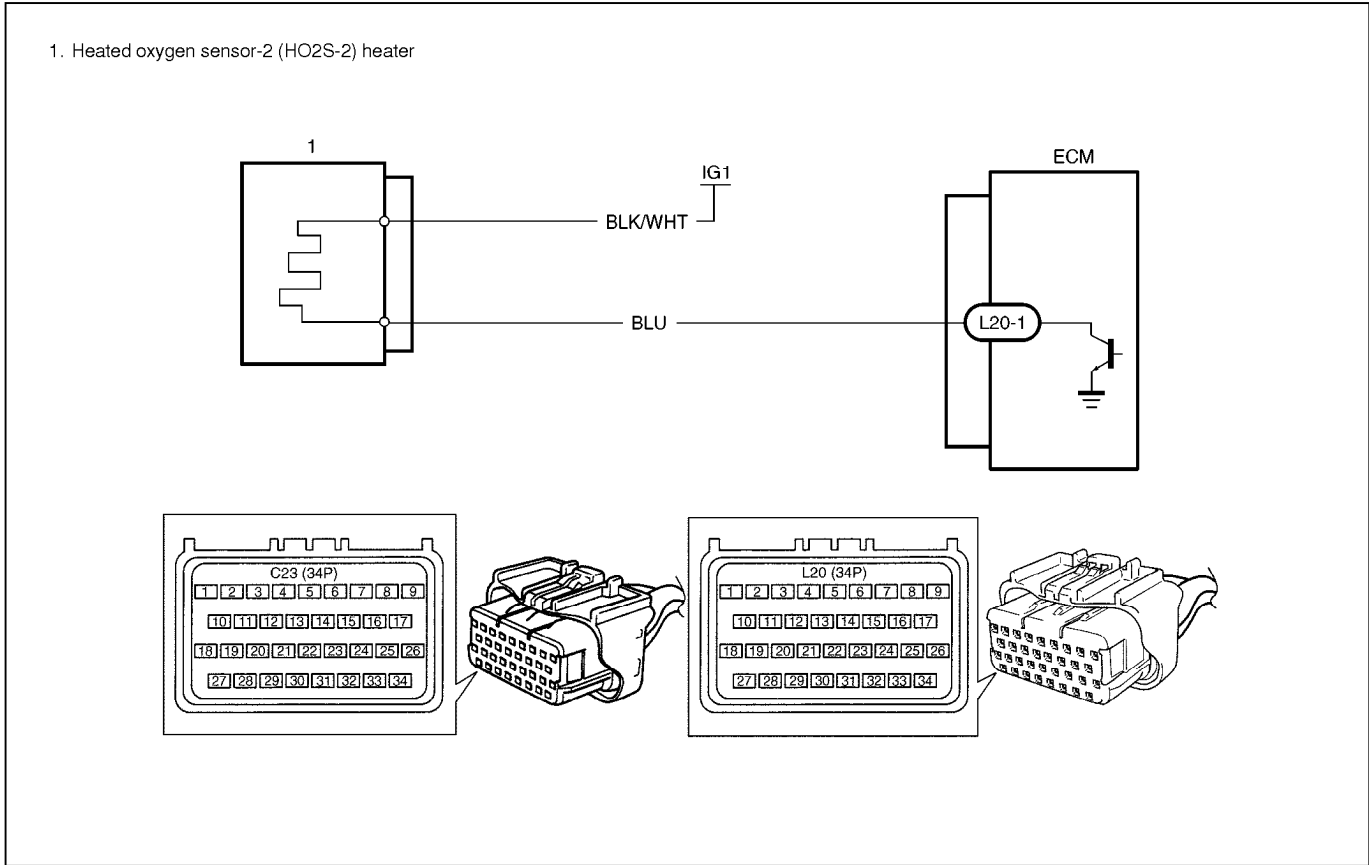

DTC DETECTING CONDITION	POSSIBLE CAUSE
<p>DTC will set when A or B condition it met.</p> <p>A. Low voltage at terminal L20-1 for specified time after engine start or while engine running at high load.</p> <p>B. High voltage at terminal L20-1 while engine running under other than above condition.</p> <p>* 2 driving cycle detection logic, continuous monitoring.</p>	<ul style="list-style-type: none"> ● HO2S-2 heater circuit open or shorted to ground ● ECM malfunction

DTC CONFIRMATION PROCEDURE

- 1) Turn ignition switch OFF once and then ON.
- 2) Clear DTC, start engine and warm up engine to normal operating temperature.
- 3) Keep it at 2000 r/min for 2 min.
- 4) Check pending DTC in "PENDING DTC" mode and DTC in "DTC" mode.

INSPECTION

STEP	ACTION	YES	NO
1	Was "ENGINE DIAG. FLOW TABLE" performed?	Go to Step 2.	Go to "ENGINE DIAG. FLOW TABLE".
2	Check HO2S-2 Heater Circuit. 1) Disconnect HO2S-2 electrical connector and ECM electrical connectors with ignition switch OFF. 2) Check "BLK/WHT" and "BLU" wires for open or short. Are "BLK/WHT" and "BLU" wires in good condition?	Intermittent trouble. Check for intermittent referring to "Intermittent and Poor Connection" in Section 0A.	Go to Step 3.
3	Check Heater or Sensor-2. 1) Disconnect HO2S-2 coupler with ignition switch OFF. 2) Check for proper connection to HO2S-2 at "BLK/WHT" and "BLU" wire terminals. 3) If OK, then check heater for resistance. Is it 11.7 – 14.3 Ω at 20°C, 68°F?	"BLU" wire open or shorted to ground or poor connection at L20-1. If wire and connection are OK, substitute a known-good ECM and recheck.	Replace HO2S-2.

DTC P0148 FUEL PRESSURE CONTROL VALVE CIRCUIT MALFUNCTION

CIRCUIT DESCRIPTION

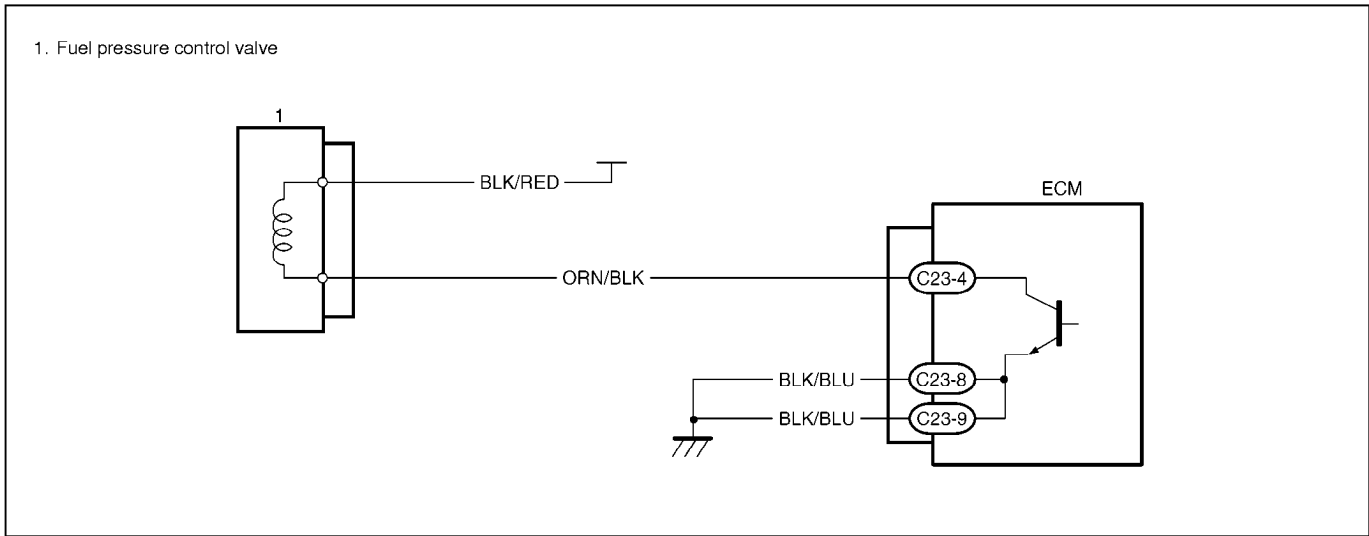

DTC DETECTING CONDITION	POSSIBLE CAUSE
Fuel pressure control valve circuit is opened or shorted.	<ul style="list-style-type: none"> ● "BLK/RED" circuit open or short ● "ORN/BLK" circuit open or short ● Fuel pressure control valve malfunction

DTC CONFIRMATION PROCEDURE

- 1) Connect scan tool to DLC with ignition switch OFF.
- 2) Turn ON ignition switch and clear DTC, pending DTC and freeze frame data by using scan tool.
- 3) Start engine and keep it at idle for 5 sec. or more.
- 4) Check DTC by using scan tool.

INSPECTION

STEP	ACTION	YES	NO
1	Was "ENGINE DIAG. FLOW TABLE" performed?	Go to Step 2.	Go to "ENGINE DIAG. FLOW TABLE".
2	Check fuel pressure control valve operation 1) With ignition switch OFF, disconnect coupler from fuel pressure control valve. 2) Check resistance of fuel pressure control valve. Resistance between two terminals : 37 – 44 Ω at 20°C (68°F) Resistance between terminal and body : 1M Ω or higher Is it as specified?	"ORN/BLK" circuit open or short.	Replace fuel pressure control valve.

Fig. 1 for Step 2

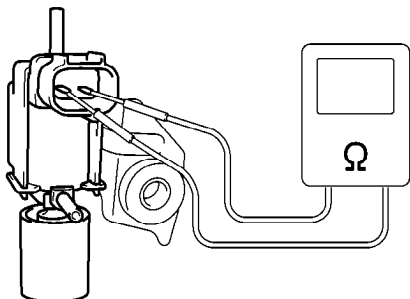

DTC P0171 FUEL SYSTEM TOO LEAN DTC P0172 FUEL SYSTEM TOO RICH

CIRCUIT DESCRIPTION

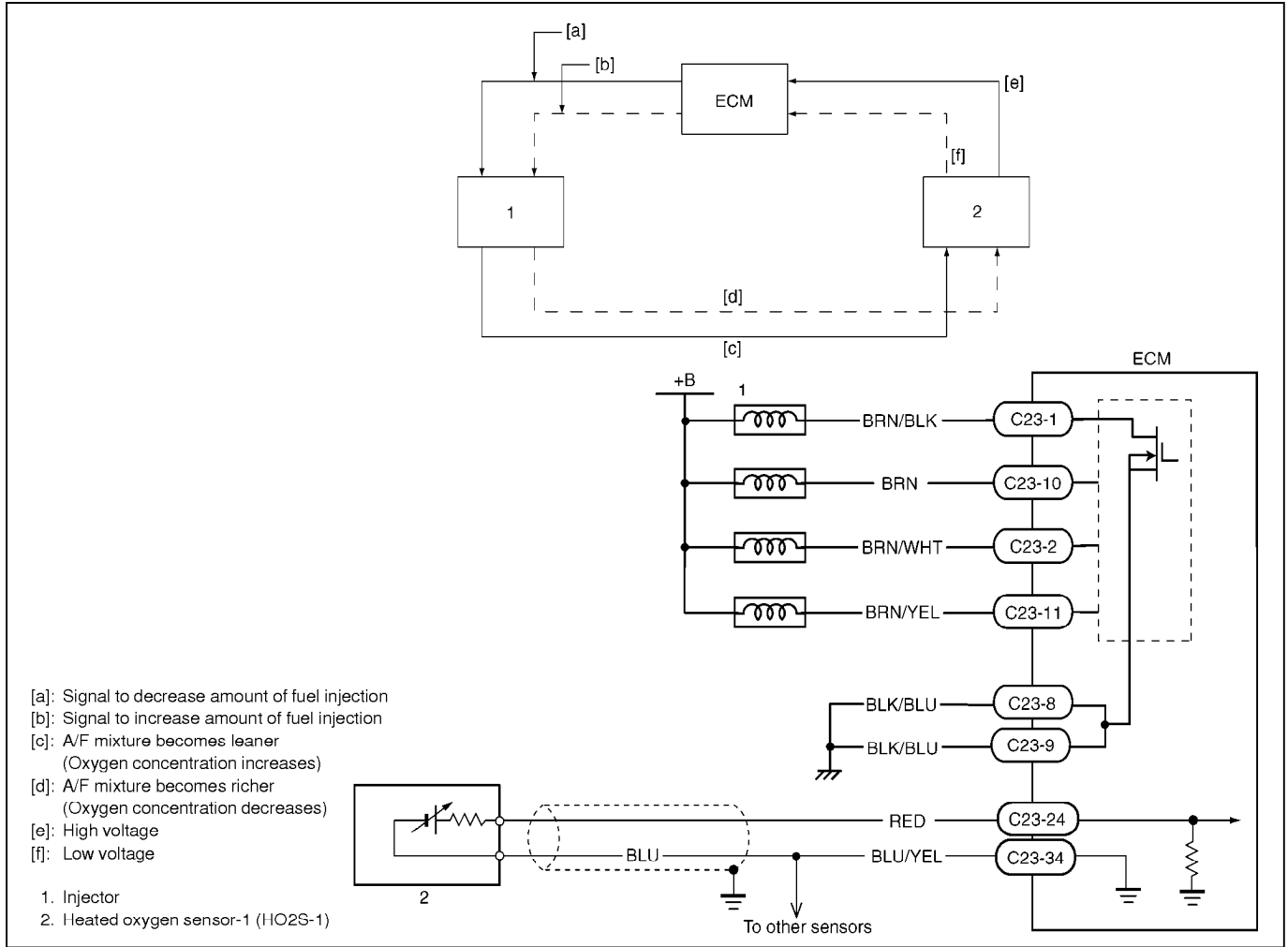

DTC DETECTING CONDITION	POSSIBLE CAUSE
<ul style="list-style-type: none"> ● When following condition occurs while engine running under closed loop condition. <ul style="list-style-type: none"> – Air/fuel ratio too lean (Total fuel trim (short and long terms added) is more than 30%) or – Air/fuel ratio too rich (Total fuel trim is less than –30%) ※ 2 driving cycle detection logic, continuous monitoring. 	<ul style="list-style-type: none"> ● Vacuum leaks (air drawn in). ● Exhaust gas leakage. ● Heated oxygen sensor-1 circuit malfunction. ● Fuel pressure out of specification. ● Fuel injector malfunction (clogged or leakage). ● MAP sensor poor performance. ● ECT sensor poor performance. ● IAT sensor poor performance. ● TP sensor poor performance. ● EVAP control system malfunction. ● PCV valve malfunction.

DTC CONFIRMATION PROCEDURE**WARNING:**

- When performing a road test, select a place where there is no traffic or possibility of a traffic accident and be very careful during testing to avoid occurrence of an accident.
- Road test should be carried out with 2 persons, a driver and a tester on a level road.

- 1) Turn ignition switch OFF.
- 2) Clear DTC with ignition switch ON.
- 3) Check vehicle and environmental condition for:
 - Altitude (barometric pressure): 2400 m, 8000 ft or less (560 mmHg, 75 kPa or more)
 - Ambient temp.: –10°C, 14°F or higher
 - Intake air temp.: 70°C, 158°F or lower
- 4) Start engine and drive vehicle under usual driving condition (described in DTC confirmation procedure of DTC P0136) for 5 min. or longer and until engine is warmed up to normal operating temperature.
- 5) Keep vehicle speed at 30 – 40 mph, 50 – 60 km/h in 5th gear for 5 min. or more.
- 6) Stop vehicle (do not turn ignition switch OFF).
- 7) Check pending DTC in “PENDING DTC” mode and DTC in “DTC” mode.

INSPECTION

STEP	ACTION	YES	NO
1	Was "ENGINE DIAG. FLOW TABLE" performed?	Go to Step 2.	Go to "ENGINE DIAG. FLOW TABLE".
2	Is there DTC(s) other than fuel system (DTC P0171/P0172)?	Go to applicable DTC Diag. Flow Table.	Go to Step 3.
3	Check HO2S-1 Output Voltage. 1) Connect scan tool to DLC with ignition switch OFF. 2) Warm up engine to normal operating temperature and keep it at 2000 r/min. for 60 sec. 3) Repeat racing engine (Repeat depressing accelerator pedal 5 to 6 times continuously and take foot off from pedal to enrich and enlean A/F mixture). Does HO2S-1 output voltage deflect between below 0.3 V and over 0.6 V repeatedly?	Go to Step 4.	Go to DTC P0130 Diag. Flow Table (HO2S-1 circuit check).
4	Check Fuel Pressure (Refer to section 6E for details). 1) Release fuel pressure from fuel feed line. 2) Install fuel pressure gauge. 3) Check fuel pressure. See Fig. 1. With fuel pump operating and engine at stop : 270 – 310 kPa, 2.7 – 3.1 kg/cm ² , 38.4 – 44.0 psi. At specified idle speed : 210 – 260 kPa, 2.1 – 2.6 kg/cm ² , 29.8 – 37.0 psi. Is measured value as specified?	Go to Step 5.	Go to Diag. Flow Table B-3 Fuel Pressure Check.
5	Check Fuel Injectors and Circuit. 1) Using sound scope (1) or such, check operating sound of each injector (2) when engine is running. Cycle of operating sound should vary according to engine speed. See Fig. 2. If no sound or an unusual sound is heard, check injector circuit (wire or coupler) or injector. 2) Turn ignition switch OFF and disconnect a fuel injector connector. 3) Check for proper connection to fuel injector at each terminal. See Fig. 3. 4) If OK, then check injector resistance. Injector Resistance: 10 – 15 ohm at 20°C (68°F) 5) Carry out steps 1) and 3) on each injector. 6) Check each injector for injected fuel volume referring to Section 6E. See Fig. 4. Injected Fuel Volume: 43 – 47 cc/15 sec (1.45/1.51 – 1.58/1.65 US/Imp.oz/15 sec) 7) Check each injector for fuel leakage after injector closed. Fuel Leakage: Less than 1 drop/min. Is check result in step 1) and 3) to 7) satisfactory?	Go to Step 6.	Check injector circuit or replace fuel injector(s).
6	Check EVAP Canister Purge Valve. 1) Disconnect purge hose (1) from EVAP canister. 2) Place finger against the end of disconnected hose. 3) Check that vacuum is not felt there when engine is cool and running at idle. See Fig. 5. Is vacuum felt?	Check EVAP control system (See Section 6E).	Go to Step 7.
7	Check intake manifold absolute pressure sensor for performance (See step 4) of DTC P0105 (No.11) Diag. Flow Table). Is it in good condition?	Go to Step 8.	Repair or replace.

STEP	ACTION	YES	NO
8	Check engine coolant temp. sensor for performance (See Section 6E). Is it in good condition?	Go to Step 9.	Replace engine coolant temp. sensor.
9	Check intake air temp. sensor for performance (See Section 6E). Is it in good condition?	Go to Step 10.	Replace intake air temp. sensor.
10	Check throttle position sensor for performance (See step 4) of DTC P0121 Diag. Flow Table). Is it in good condition?	Go to Step 11.	Replace throttle position sensor.
11	Check PCV valve for valve clogging (See Section 6E). Is it good condition?	Substitute a known-good ECM and recheck.	Replace PCV valve.

Fig. 1 for Step 4

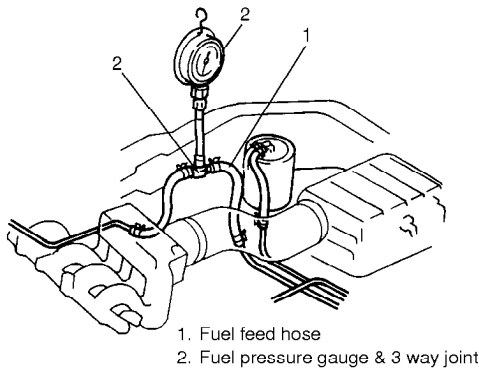

Fig. 2 for Step 5

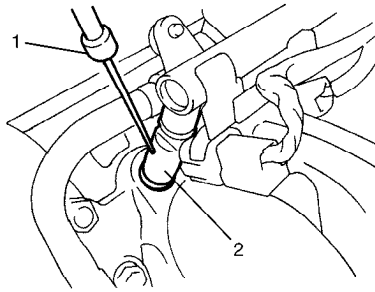

Fig. 3 for Step 5

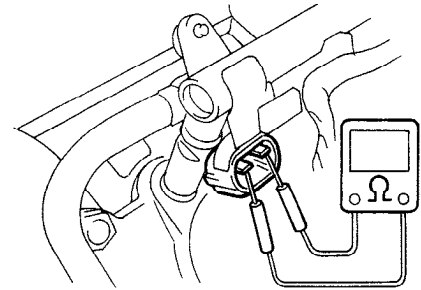

Fig. 4 for Step 5

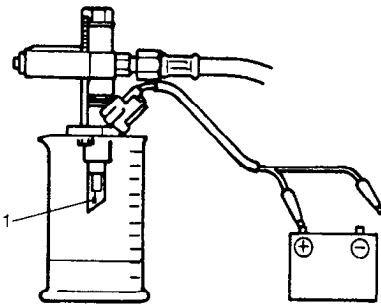
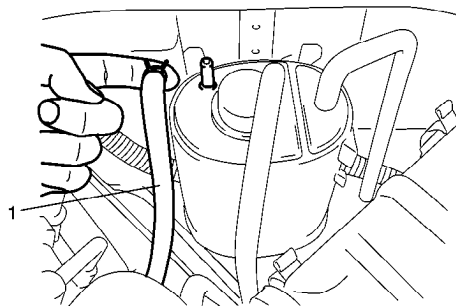
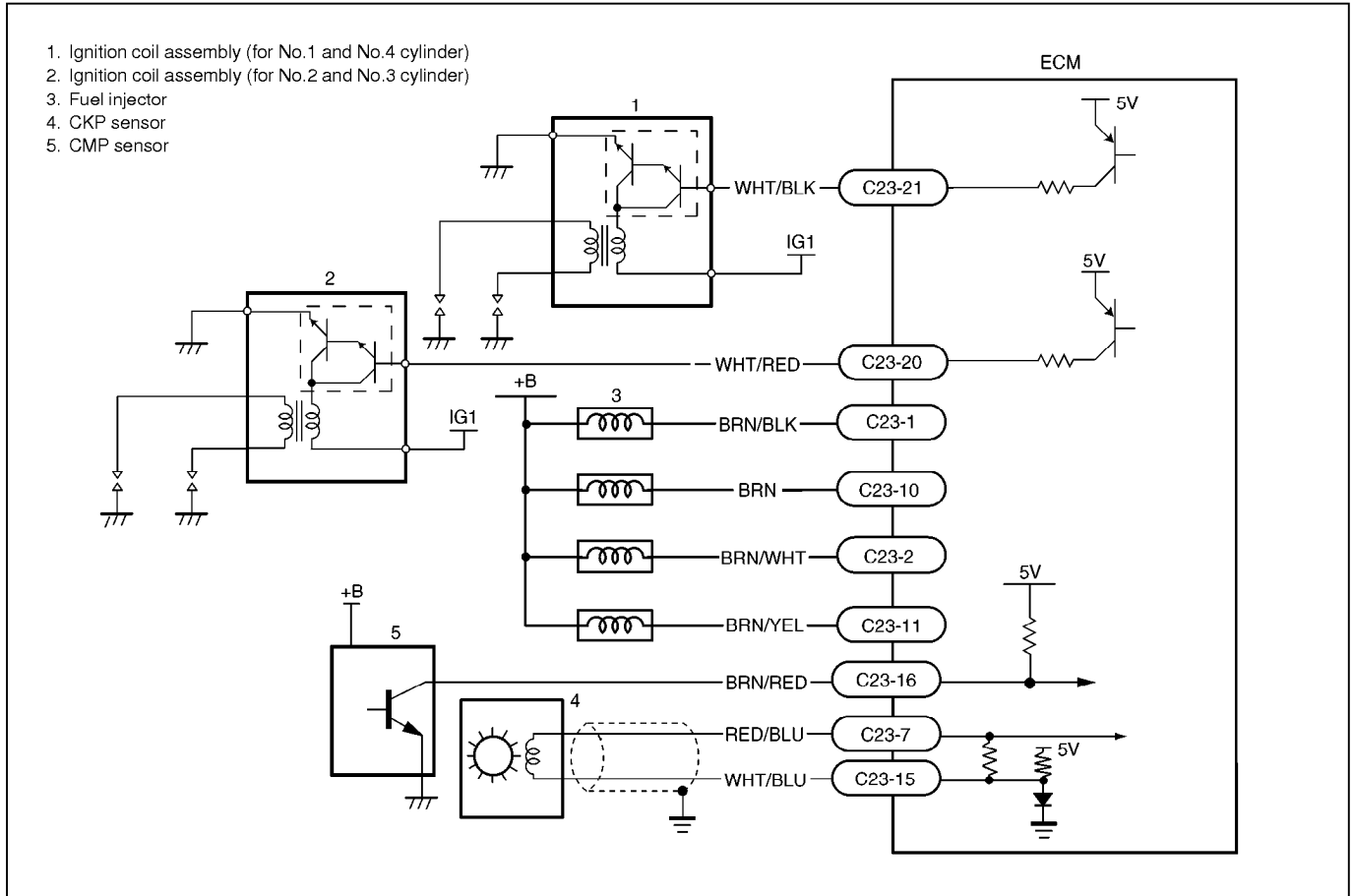

Fig. 5 for Step 6



DTC P0300 RANDOM MISFIRE DETECTED (Misfire detected at 2 or more cylinders)**DTC P0301 CYLINDER 1 MISFIRE DETECTED****DTC P0302 CYLINDER 2 MISFIRE DETECTED****DTC P0303 CYLINDER 3 MISFIRE DETECTED****DTC P0304 CYLINDER 4 MISFIRE DETECTED****CIRCUIT DESCRIPTION**

ECM monitors crankshaft revolution speed and engine speed via the crankshaft position sensor and cylinder No. via the camshaft position sensor. Then it calculates the change in the crankshaft revolution speed and from how many times such change occurred in every 200 or 1000 engine revolutions, it detects occurrence of misfire.

When ECM detects a misfire (misfire rate per 200 revolutions) which can cause overheat and damage to the three way catalytic converter, it makes the malfunction indicator lamp (MIL) flash as long as misfire occurs at that rate. After that, however, when the misfire rate drops, MIL remains ON until it has been judged as normal 3 times under the same driving conditions.

Also, when ECM detects a misfire (misfire rate per 1000 revolutions) which will not cause damage to three way catalytic converter but can cause exhaust emission to be deteriorated, it makes MIL light according to the 2 driving cycle detection logic.

DTC DETECTING CONDITION	POSSIBLE CAUSE
<ul style="list-style-type: none"> ● Engine under other than high revolution condition ● Not on rough road ● Engine speed changing rate ● Manifold absolute pressure changing rate ● Throttle opening changing rate ● Misfire rate per 200 or 1000 engine revolutions (how much and how often crankshaft revolution speed changes) is higher than specified value 	<ul style="list-style-type: none"> ● Engine overheating ● Vacuum leaks (air inhaling) from air intake system ● Ignition system malfunction (spark plug(s), high-tension cord(s), ignition coil assembly) ● Fuel pressure out of specification ● Fuel injector malfunction (clogged or leakage) ● Engine compression out of specification ● Valve lash (clearance) out of specification ● Manifold absolute pressure sensor malfunction ● Engine coolant temp. sensor malfunction ● PCV valve malfunction ● EVAP control system malfunction ● EGR system malfunction

DTC CONFIRMATION PROCEDURE

NOTE:

Among different types of random misfire, if misfire occurs at cylinders 1 and 4 or cylinders 3 and 2 simultaneously, it may not possible to reconfirm DTC by using the following DTC confirmation procedure. When diagnosing the trouble of DTC P0300 (Random misfire detected) of the engine which is apparently misfiring, even if DTC P0300 cannot be reconfirmed by using the following DTC confirmation procedure, proceed to the following Diag. Flow Table.

WARNING:

- When performing a road test, select a place where there is no traffic or possibility of a traffic accident and be very careful during testing to avoid occurrence of an accident.
- Road test should be carried out with 2 persons, a driver and a tester.

- 1) Turn ignition switch OFF.
- 2) Clear DTC with ignition switch ON.
- 3) Check vehicle and environmental condition for:
 - Altitude (barometric pressure): 2400 m, 8000 ft or less (560 mmHg, 75 kPa or more)
 - Ambient temp.: -10°C, 14°F or higher
 - Intake air temp.: 70°C, 158°F or lower
 - Engine coolant temp.: -10 – 110°C, 14 – 230°F
- 4) Start engine and keep it at idle for 2 min. or more.
- 5) Check DTC in “DTC” mode and pending DTC in “PENDING DTC” mode.
- 6) If DTC is not detected at idle, consult usual driving based on information obtained in “Customer complaint analysis” and “Freeze frame data check”.

INSPECTION

STEP	ACTION	YES	NO
1	Was "ENGINE DIAG. FLOW TABLE" performed?	Go to Step 2.	Go to "ENGINE DIAG. FLOW TABLE".
2	Is there DTC other than Fuel system (DTC P0171/P0172) and misfire (DTC P0300-P0304)?	Go to applicable DTC Diag. Flow Table.	Go to Step 3.
3	<p>Check Ignition System.</p> <p>1) Remove spark plugs and check them for;</p> <ul style="list-style-type: none"> ● Air gap: 1.0 – 1.1 mm (0.040 – 0.043 in.) See Fig. 1. ● Carbon deposits/Insulator damage/Plug type <p>If abnormality is found, adjust, clean or replace by referring to Section 6F.</p> <p>2) Disconnect all injector connectors.</p> <p>3) Connect spark plugs to high tension cords and then ground spark plugs.</p> <p>4) Crank engine and check that each spark plug sparks.</p> <p>Are above check results satisfactory?</p>	Go to Step 4.	Check ignition system parts (Refer to Section 6F).
4	<p>Check Fuel Pressure (Refer to Section 6E for details).</p> <p>1) Release fuel pressure from fuel feed line.</p> <p>2) Install fuel pressure gauge. See Fig. 2.</p> <p>3) Check fuel pressure.</p> <p>With fuel pump operating and engine at stop : 270 – 310 kPa, 2.7 – 3.1 kg/cm², 38.4 – 44.0 psi.</p> <p>At specified idle speed : 210 – 260 kPa, 2.1 – 2.6 kg/cm², 29.8 – 37.0 psi.</p> <p>Is measured value as specified?</p>	Go to Step 5.	Go to Diag. Flow Table B-3 fuel pressure check.
5	<p>Check Fuel Injectors and Circuit.</p> <p>1) Using sound scope (1) or such, check operating sound of each injector (2) when engine is running. Cycle of operating sound should vary according to engine speed. See Fig 3.</p> <p>If no sound or an unusual sound is heard, check injector circuit (wire or coupler) or injector.</p> <p>2) Turn ignition switch OFF and disconnect a fuel injector connector.</p> <p>3) Check for proper connection to fuel injector at each terminal. See Fig. 4.</p> <p>4) If OK, then check injector resistance.</p> <p>Injector Resistance: 10 – 15 ohm at 20°C (68°F)</p> <p>5) Carry out steps 1) and 3) on each injector.</p> <p>6) Check each injector for injected fuel volume referring to Section 6E. See Fig. 5.</p> <p>Injected Fuel Volume: 43 – 47 cc/15 sec (1.45/1.51 – 1.58/1.65 US/Imp. oz/15 sec)</p> <p>7) Check each injector for fuel leakage after injector closed.</p> <p>Fuel Leakage: Less than 1 drop/min.</p> <p>Is check result in step 1) and 3) to 7) satisfactory?</p>	Go to Step 6.	Check injector circuit or replace fuel injector(s).

STEP	ACTION	YES	NO
6	Check PCV valve for clogging (See Section 6E). Is it in good condition?	Go to Step 7.	Replace PCV valve.
7	Check EVAP Canister Purge Valve for Closing. 1) Disconnect purge hose (1) from EVAP canister. 2) Place finger against the end of disconnected hose. 3) Check that vacuum is not felt there, when engine is cool and running at idle. See Fig. 6. Is vacuum felt?	Check EVAP control system (See Section 6E).	Go to Step 8.
8	Check manifold absolute pressure sensor for performance (See step 4) DTC P0105 Diag. Flow Table). Is it in good condition?	Go to Step 9.	Repair or replace.
9	Check engine coolant temp. sensor for performance (See Section 6E). Is it in good condition?	Go to Step 10.	Replace engine coolant temp. sensor.
10	Check parts or system which can cause engine rough idle or poor performance. – Engine compression (See Section 6A). – Valve lash (See Section 6A). – Valve timing (Timing belt installation. See Section 6A). Are they in good condition?	Check wire harness and connection of ECM ground, ignition system and fuel injector for intermittent open and short.	Repair or replace.

Fig. 1 for Step 3

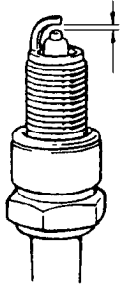

Fig. 2 for Step 4

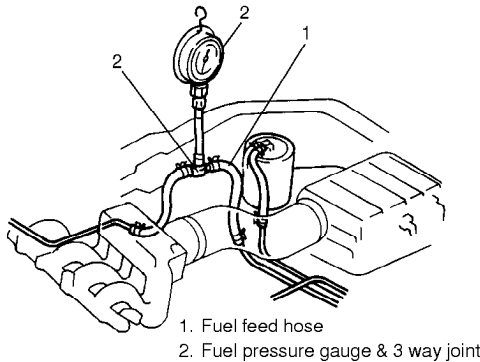

Fig. 3 for Step 5

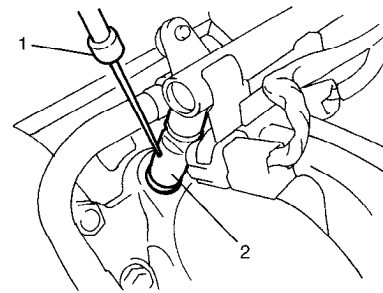

Fig. 4 for Step 4

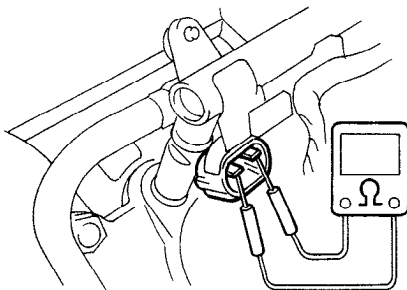

Fig. 5 for Step 5

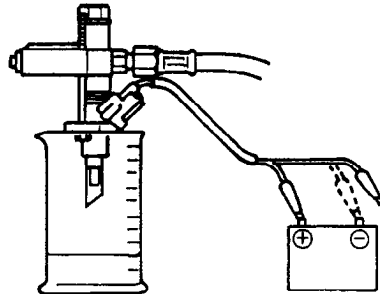
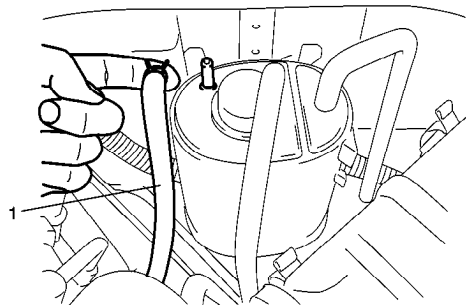
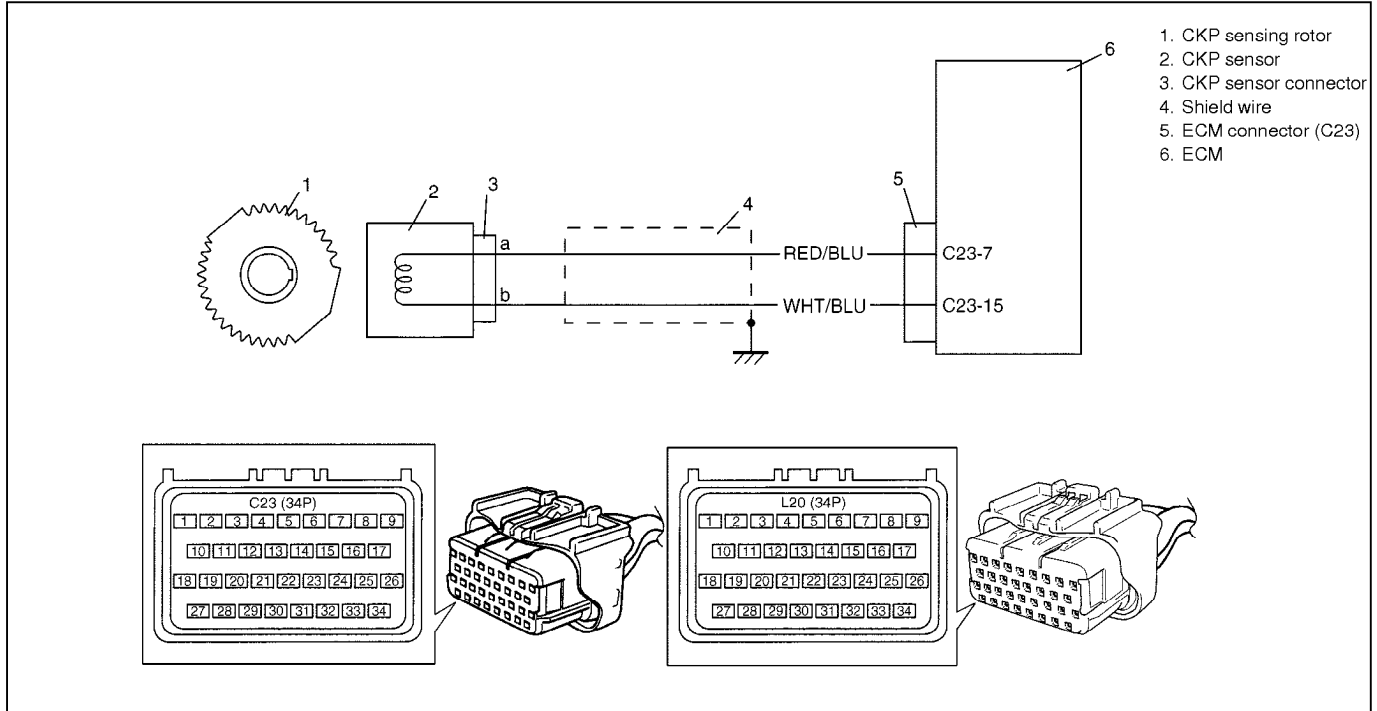

Fig. 6 for Step 7



DTC P0335 CRANKSHAFT POSITION (CKP) SENSOR CIRCUIT (DTC No.23) MALFUNCTION

CIRCUIT DESCRIPTION



DTC DETECTING CONDITION	POSSIBLE CAUSE
<ul style="list-style-type: none"> • NO CKP sensor signal for 2 seconds at engine cranking. 	<ul style="list-style-type: none"> • CKP sensor circuit open or short. • Signal teeth damaged. • CKP sensor malfunction, foreign material being attached or improper installation. • ECM malfunction.

DTC CONFIRMATION PROCEDURE

- 1) Clear DTC and crank engine for 2 sec.
- 2) Select "DTC" mode on scan tool and check DTC.

INSPECTION**NOTE:**

If starter circuit is open (i.e., start signal circuit is OK but starter fails to run), this DTC is stored in memory at starter switch ON, even though CKP sensor is in good condition.

When starter motor fails to run and this DTC appears, check starter circuit first.

STEP	ACTION	YES	NO
1	Was "ENGINE DIAG. FLOW TABLE" performed?	Go to Step 2.	Go to "ENGINE DIAG. FLOW TABLE".
2	Is there DTC P1500 (Engine starter signal circuit)?	Go to DTC P1500 Diag. Flow Table.	Go to Step 3.
3	<p>Check CKP Sensor for Resistance.</p> <p>1) Disconnect CKP sensor connector with ignition switch OFF.</p> <p>2) Then check for proper connection to CKP sensor at "RED/BLU" and "WHT/BLU" wire terminals.</p> <p>3) If OK, measure sensor resistance between terminals. See Fig. 1. CKP sensor resistance: 360 – 460 Ω at 20°C, 68°F</p> <p>4) Measure resistance between each terminal and ground.</p> <p>Insulation resistance: 1 MΩ or more.</p> <p>Were measured resistance values in step 3) and 4) as specified?</p>	Go to Step 4.	Replace CKP sensor.
4	<p>Check visually CKP sensor and pulley for the following. See Fig.2.</p> <ul style="list-style-type: none"> ● Damage ● No foreign material attached. ● Correct installation. <p>Are they in good condition?</p>	<p>"RED/BLU" or "WHT/BLU" wire open or shorted to ground, or poor connection at C23-7 or C23-15.</p> <p>If wire and connection are OK, intermittent trouble or faulty ECM. Recheck for intermittent referring to "Intermittent and Poor Connection" in Section 0A.</p>	Clean, repair or replace.

Fig. 1 for Step 3

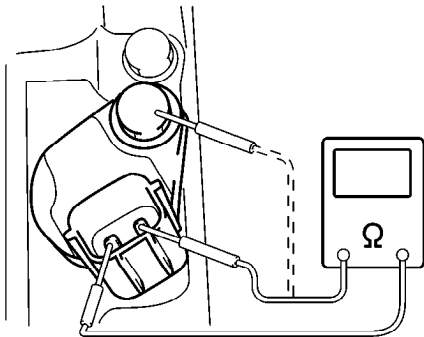
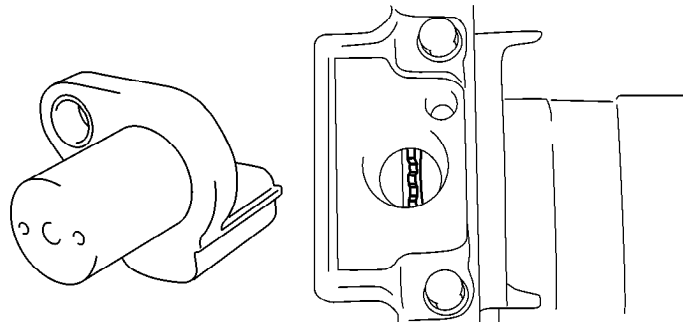
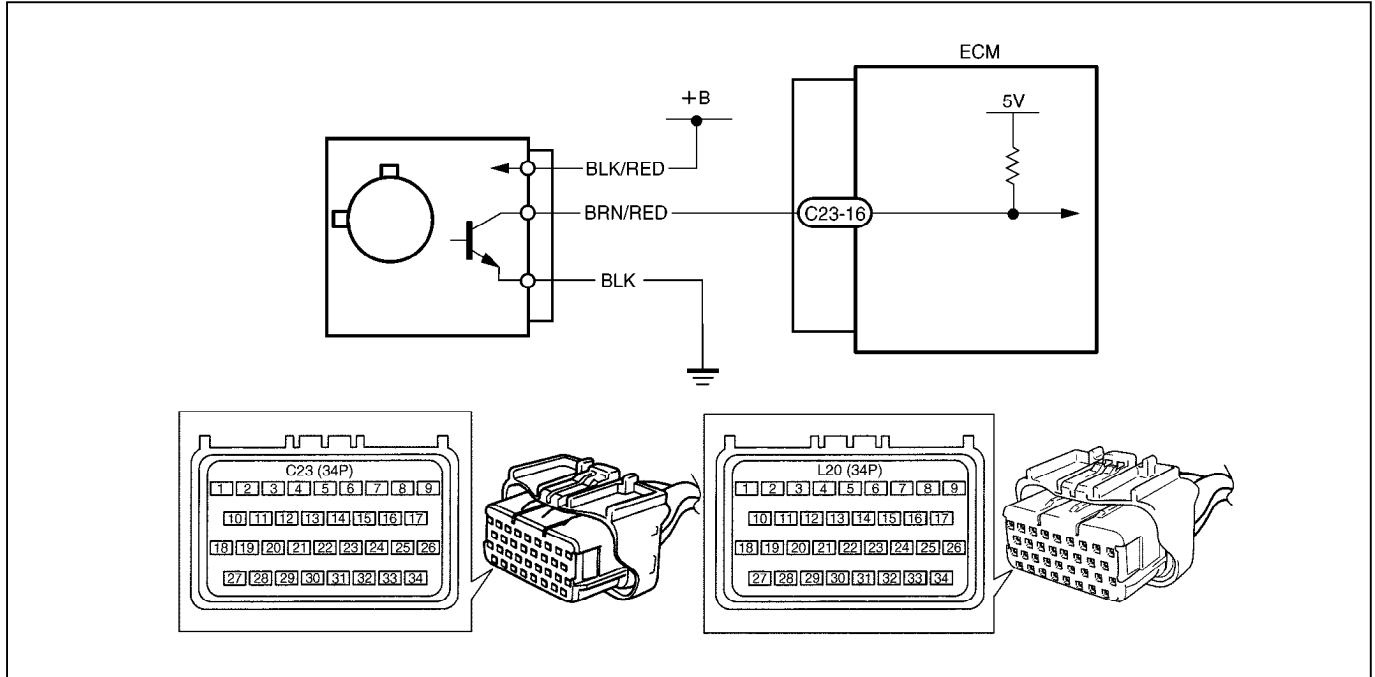

Fig. 2 for Step 4



DTC P0340 CAMSHAFT POSITION (CMP) SENSOR CIRCUIT MALFUNCTION (DTC No.15)

CIRCUIT DESCRIPTION



DTC DETECTING CONDITION	POSSIBLE CAUSE
<ul style="list-style-type: none"> The number of CMP sensor signal pulses is incorrect during 6 revolution of crankshaft. 	<ul style="list-style-type: none"> CMP sensor circuit open or short. Signal rotor teeth damaged. CMP sensor malfunction, foreign material being attached or improper installation. ECM malfunction. CMP sensor phase lag.

DTC CONFIRMATION PROCEDURE

- 1) Clear DTC.
- 2) Start engine and keep it at idle for 1 min.
- 3) Select "DTC" mode on scan tool and check DTC.

INSPECTION

STEP	ACTION	YES	NO
1	Was "ENGINE DIAG. FLOW TABLE" performed?	Go to Step 2.	Go to "ENGINE DIAG. FLOW TABLE".
2	Check CMP Sensor and connector for proper installation. Is CMP sensor installed properly and connector connected securely?	Go to Step 3.	Correct.
3	Check Wire Harness and Connection. 1) Disconnect connector from CMP sensor. 2) Check for proper connection to CMP sensor at each terminal. 3) If OK, turn ignition switch ON and check for voltage at each terminal of sensor connector disconnected. See Fig. 1. Terminal "B+" : 10 – 14 V Terminal "Vout" : 4 – 5 V Terminal "GND" : 0 V Is check result satisfactory?	Go to Step 5.	Go to Step 4.
4	Was terminal "Vout" voltage out of specification in Step 3 check?	"BRN/RED" wire open, short or poor connection. If wire and connection are OK, substitute a known-good ECM and recheck.	"BLK/RED" or "BLK" wire open, short or poor connection.
5	Check Ground Circuit for Open. 1) Turn ignition switch OFF. 2) Check for continuity between "GND" terminal of CMP sensor connector and engine ground. Is continuity indicated?	Go to Step 6.	"BLK" wire open or poor ground connection.
6	Check signal rotor for the following using mirror. See Fig. 2. ● Damage ● No foreign material attached Is it in good condition?	Intermittent trouble or faulty ECM. Faulty CMP sensor. Check for intermittent referring to "Intermittent and Poor Connection" in Section 0A.	Clean rotor teeth.

Fig. 1 for Step 3

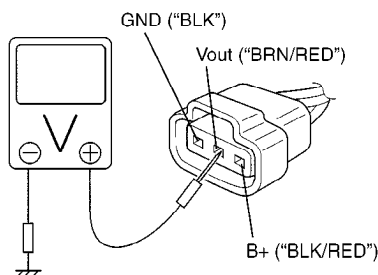
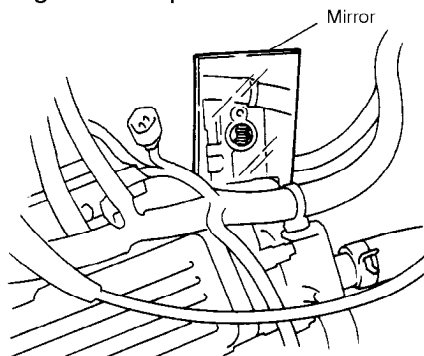
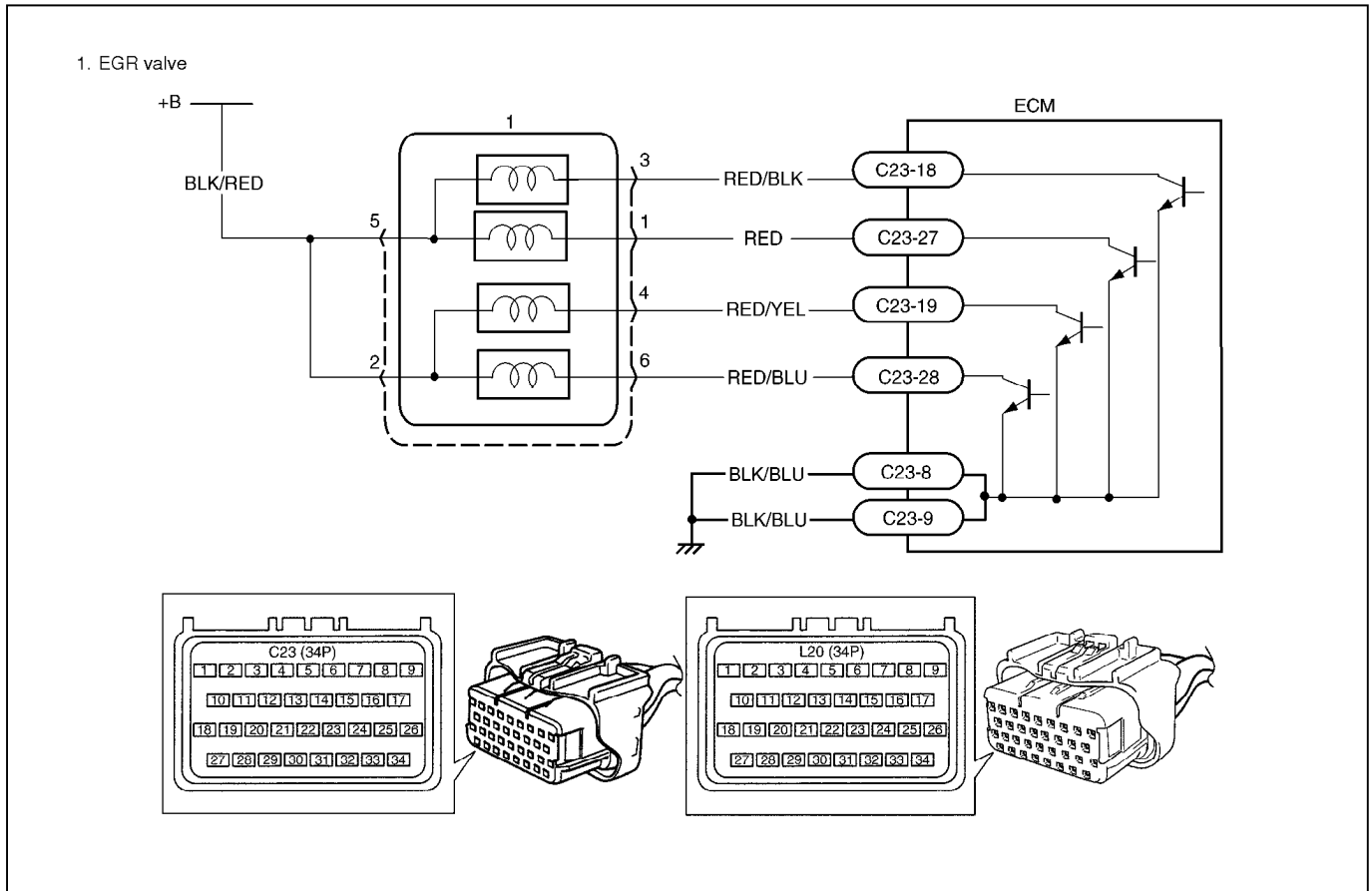

Fig. 2 for Step 7



DTC P0400 EXHAUST GAS RECIRCULATION FLOW MALFUNCTION

CIRCUIT DESCRIPTION



DTC DETECTING CONDITION	POSSIBLE CAUSE
<ul style="list-style-type: none"> ● While running at specified vehicle speed after engine warm-up ● During deceleration (engine speed high with closed throttle position ON) in which fuel cut is involved, difference in intake manifold absolute pressure between when EGR valve is opened at specified value and when it is closed is larger or smaller than specified value. <p>※ 2 driving cycle detection logic, monitoring once/1 driving</p>	<ul style="list-style-type: none"> ● EGR valve or its circuit ● EGR passage ● ECM ● MAP sensor

DTC CONFIRMATION PROCEDURE**WARNING:**

- When performing a road test, select a place where there is no traffic or possibility of a traffic accident and be very careful during testing to avoid occurrence of an accident.
- Road test should be carried out with 2 persons, a driver and a tester, on a level road.

1) Turn ignition switch OFF.

Clear DTC with ignition switch ON, check vehicle and environmental condition for:

- Altitude (barometric pressure): 2400 m, 8000 ft or less (560 mmHg, 75 kPa or more)
- Ambient temp.: -10°C , 14°F or higher
- Intake air temp.: 70°C , 122°F or lower
- Engine coolant temp.: 70°C , 158°F or higher

2) Start engine and warm it up to normal operating temperature ($70 - 110^{\circ}\text{C}$, $158 - 230^{\circ}\text{F}$) and run it at idle for 5 min.

3) Increase vehicle speed to 50 – 55 mph, 80 – 88 km/h in 5th gear.

4) Hold throttle valve at that opening position for 2 min. or longer.

5) Increase engine speed to 4000 r/min. in 3rd gear.

6) Release accelerator pedal and with engine brake applied, keep vehicle coasting (fuel cut condition) till engine speed reaches 1500 r/min.

7) Stop vehicle (don't turn ignition switch OFF) and confirm test results according to following "Test Result Confirmation Flow Table."

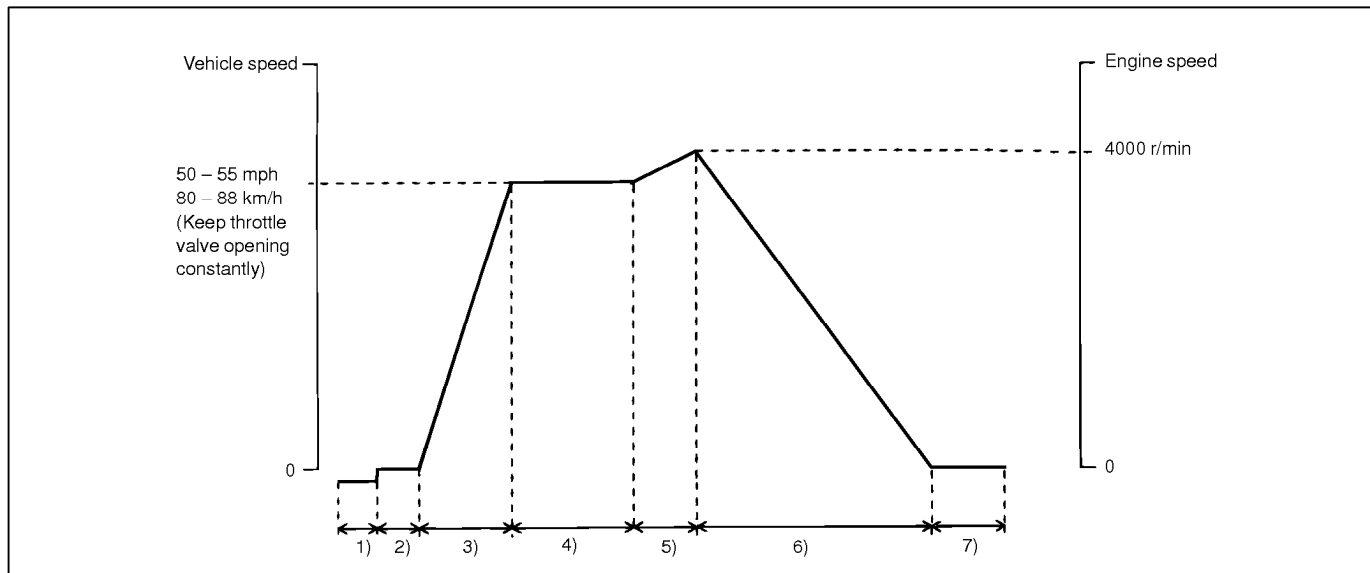
**Test Result Confirmation Flow Table**

STEP	ACTION	YES	NO
1	Check DTC in "DTC" mode and pending DTC in "ON BOARD TEST". Is DTC or pending DTC displayed?	Proceed to applicable DTC flow table.	Go to Step 2.
2	Set scan tool to "READINESS TESTS" mode and check if testing has been completed. Is test completed?	No DTC is detected. (Confirmation test is completed)	Repeat DTC confirmation procedure.

DTC P0400**INSPECTION**

STEP	ACTION	YES	NO
1	Was "ENGINE DIAG. FLOW TABLE" performed?	Go to Step 2.	Go to "ENGINE DIAG. FLOW TABLE".
2	EGR Valve Operation Check: 1) With ignition switch OFF, install SUZUKI scan tool. 2) Check EGR system referring to Section 6E. Is it in good condition?	Go to Step 3.	Go to Step 4.
3	MAP Sensor Check: 1) Check MAP sensor for performance referring to Section 6E. Is check result satisfactory?	Intermittent trouble or faulty ECM. Check for intermittent referring to "Intermittent and Poor Connection" in Section 0A.	Repair or replace.
4	EGR Valve Power Supply Circuit Check: 1) With ignition switch OFF, disconnect EGR valve coupler. 2) With ignition switch ON, check voltage between "a" and ground, "b" and ground. Is each voltage 10 – 14 V?	Go to Step 5.	Faulty "BLK/RED" wire.
5	EGR Valve Stepper Motor Coil Circuit Check: 1) With ignition switch OFF, connect EGR valve coupler and disconnect ECM couplers. 2) Check resistance between L20-2 and C23-18, C23-19, C23-27, C23-28. Is each resistance 20 – 24 Ω at 20°C, 68°F?	Go to Step 6.	Faulty "RED/BLK" "RED", "RED/YEL", "RED/BLU" wire or EGR valve.
6	MAP Sensor Check: 1) Check MAP sensor for performance referring to MAP SENSOR INDIVIDUAL CHECK in Diag. FLOW TABLE P0105. Is check result satisfactory?	EGR passage clogged or EGR valve malfunction. If all above are OK, intermittent trouble or faulty ECM. Check for intermittent referring to "Intermittent and Poor Connection" in Section 0A.	Repair or replace.

Fig. 1 for Step 5

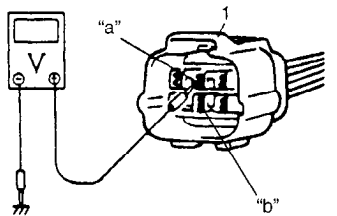

1. EGR valve connector

DTC P0420 CATALYST SYSTEM EFFICIENCY BELOW THRESHOLD

CIRCUIT DESCRIPTION

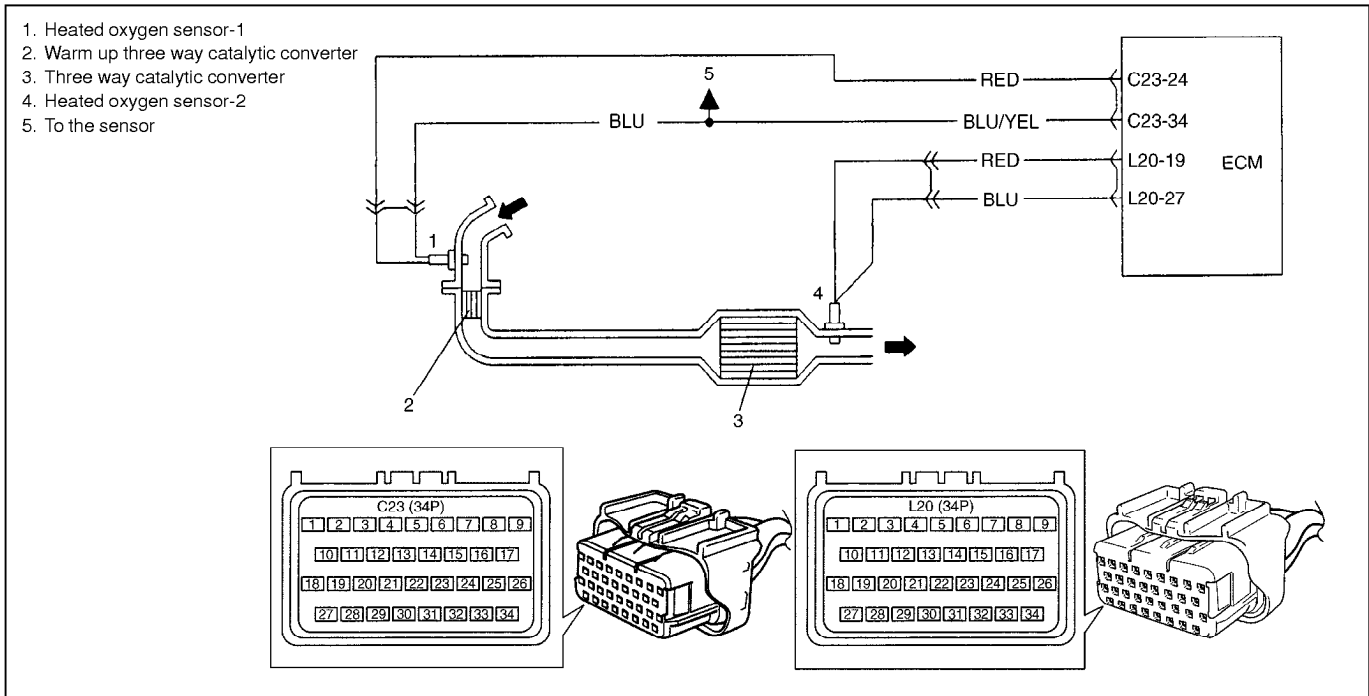

ECM monitors oxygen concentration in the exhaust gas which has passed the three way catalytic converter by HO2S-2.

When the catalyst is functioning properly, the variation cycle of HO2S-2 output voltage (oxygen concentration) is slower than that of HO2S-1 output voltage because of the amount of oxygen in the exhaust gas which has been stored in the catalyst.

Reference

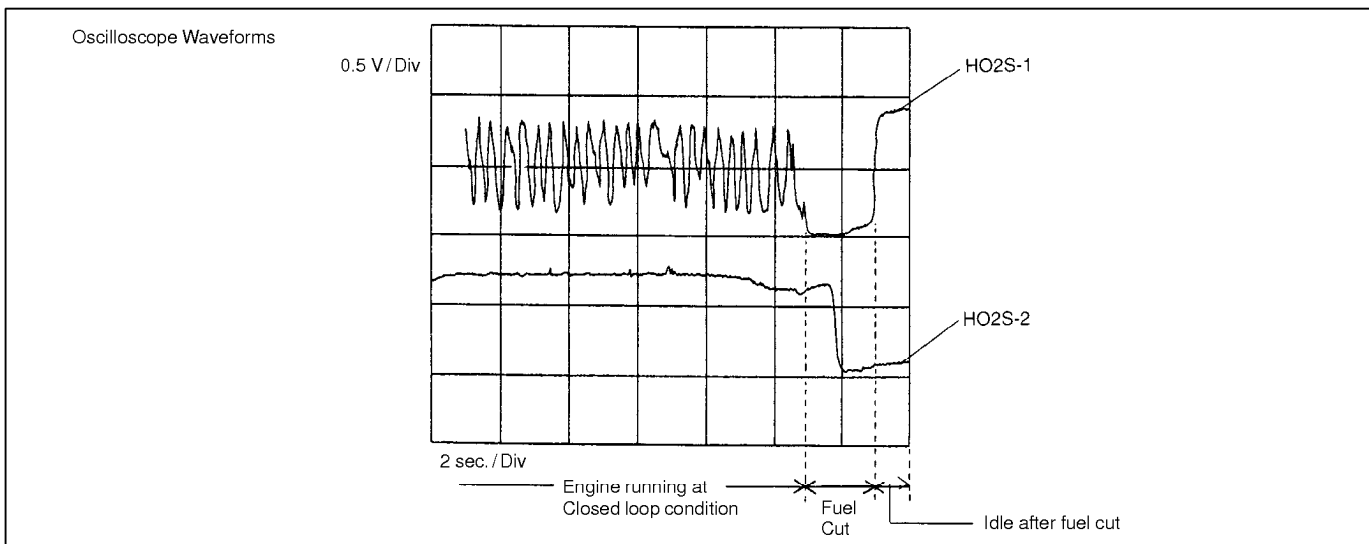

DTC DETECTING CONDITION	POSSIBLE CAUSE
<ul style="list-style-type: none"> ● While vehicle running at constant speed under other than high load. ● Time from rich or lean switching command is output till HO2S-2 output voltage crosses 0.45 V less than specified value. * 2 driving cycle detection logic, monitoring once/1 driving. 	<ul style="list-style-type: none"> ● Exhaust gas leak ● Three way catalytic converter malfunction ● Fuel system malfunction ● HO2S-2 malfunction ● HO2S-1 malfunction

DTC CONFIRMATION PROCEDURE**WARNING:**

- When performing a road test, select a place where there is no traffic or possibility of a traffic accident and be very careful during testing to avoid occurrence of an accident.
- Road test should be carried out with 2 persons, a driver and a tester, on a level road.

1) Turn ignition switch OFF.

Clear DTC with ignition switch ON, check vehicle and environmental condition for:

- Altitude (barometric pressure): 2400 m, 8000 ft or less (560 mmHg, 75 kPa or more)
- Ambient temp.: -10°C , 14°F or higher
- Intake air temp.: 70°C , 158°F or lower
- Engine coolant temp.: $70 - 110^{\circ}\text{C}$, $158 - 230^{\circ}\text{F}$

2) Start engine and drive vehicle at 35 – 45 mph, 55 – 65 km/h for 8 min. or longer.

While this driving, if “Catalyst Monitoring TEST COMPLETED” is displayed in “READINESS TESTS” mode and DTC is not displayed in “DTC” mode, confirmation test is completed.

If “TEST NOT COMPLTD” is still being displayed, continue test driving.

- 3) Decrease vehicle speed at 30 – 40 mph, 50 – 60 km/h, and hold throttle valve at that opening position for 2 min. and confirm that short term fuel trim vary within -20% $-+20\%$ range.
- 4) Stop vehicle (do not turn ignition switch OFF) and confirm test results according to following “Test Result Confirmation Flow Table”.

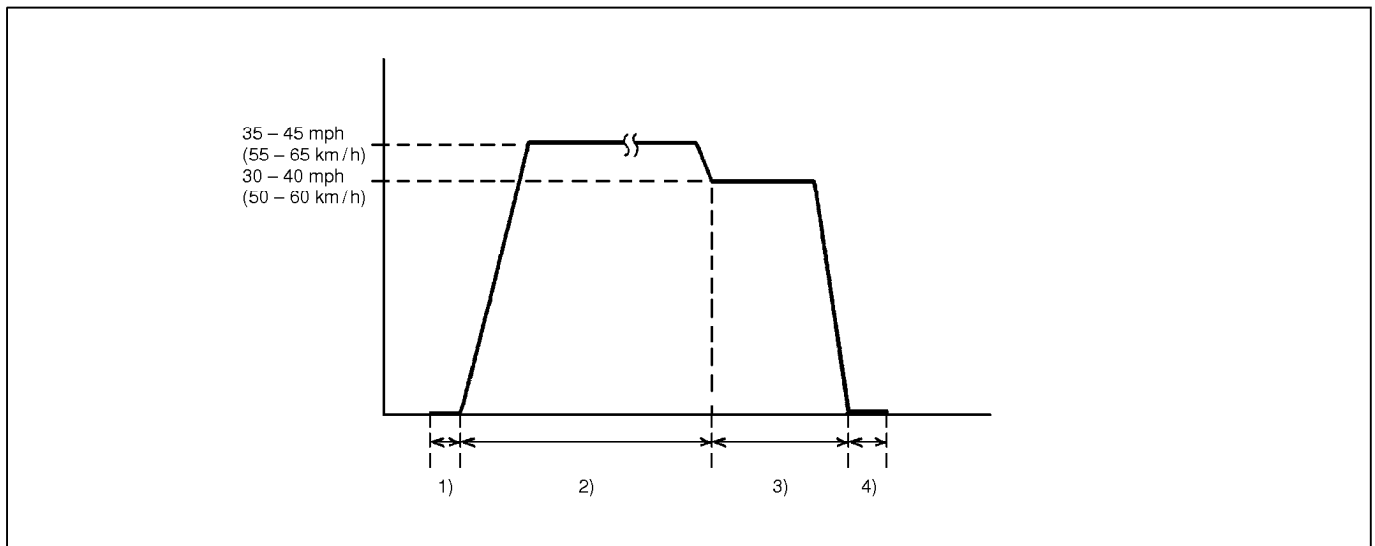
**Test Result Confirmation Flow Table**

STEP	ACTION	YES	NO
1	Check DTC in “DTC” mode and pending DTC in “ON BOARD TEST” or “PENDING DTC” mode. Is DTC or pending DTC displayed?	Proceed to applicable DTC Diag. Flow Table.	Go to Step 2.
2	Set scan tool to “READINESS TESTS” mode and check if testing has been completed. Is test completed?	No DTC is detected (confirmation test is completed).	Repeat DTC confirmation procedure.

DTC P0420**INSPECTION**

STEP	ACTION	YES	NO
1	Was "ENGINE DIAG. FLOW TABLE" performed?	Go to Step 2.	Go to "ENGINE DIAG. FLOW TABLE".
2	Check Short Term Fuel Trim. Did short term fuel trim vary within -20% $-+20\%$ range in step 3) of DTC confirmation test?	Go to Step 3.	Check fuel system. Go to DTC P0171/P0172 Diag. Flow Table.
3	Check HO2S-2 for Output Voltage. Perform steps 1) through 9) of DTC confirmation procedure for DTC P0136 (HO2S-2 malfunction) and check output voltage of HO2S-2 then. Is over 0.6 V and below 0.3 V indicated?	Replace three way catalytic converter.	Check "RED" and "BLU" wires for open and short, and connections for poor connection. If wires and connections are OK, replace HO2S-2.

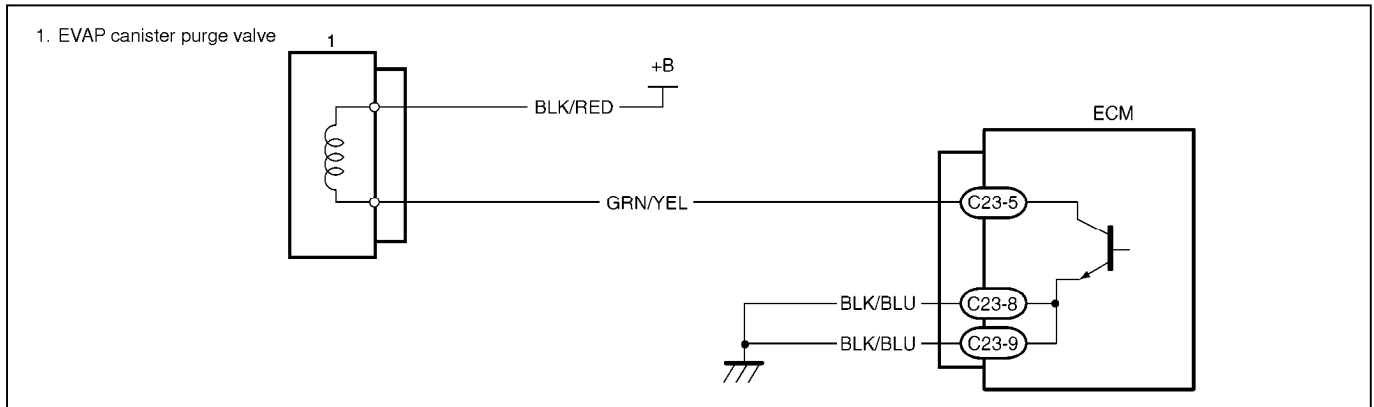
DTC P0443 PURGE CONTROL VALVE CIRCUIT MALFUNCTION**CIRCUIT DESCRIPTION**

DTC DETECTING CONDITION	POSSIBLE CAUSE
Canister Purge control valve circuit is opened or shorted.	<ul style="list-style-type: none"> ● "GRN/YEL" circuit open or short ● "BLK/RED" circuit open or short ● Canister purge valve malfunction ● ECM

DTC CONFIRMATION PROCEDURE

- 1) Connect scan tool to DLC with ignition switch OFF.
- 2) Turn ON ignition switch and clear DTC, pending DTC and freeze frame data by using scan tool.
- 3) Start engine and keep it at idle for 5 sec. or more.
- 4) Check DTC and pending DTC by using scan tool.

INSPECTION

STEP	ACTION	YES	NO
1	Was "ENGINE DIAG. FLOW TABLE" performed?	Go to Step 2.	Go to "ENGINE DIAG. FLOW TABLE".
2	Check EVAP canister purge system for operation referring to "EVAP Canister Purge Inspection" in Section 6E. Is check result satisfactory?	Intermittent trouble or faulty ECM. Check for intermittent referring to "Intermittent and Poor Connection" in Section 0A.	Go to Step 3.
3	Check EVAP canister purge valve operation 1) With ignition switch OFF, disconnect coupler from canister purge valve. 2) Check resistance of EVAP canister purge valve. Resistance between two terminals : 30 – 34 Ω at 20°C (68°F) Resistance between terminal and body : 1M Ω or higher Is it as specified?	"GRN/YEL" circuit open or short.	Replace EVAP canister purge valve.

Fig. 1 for Step 1

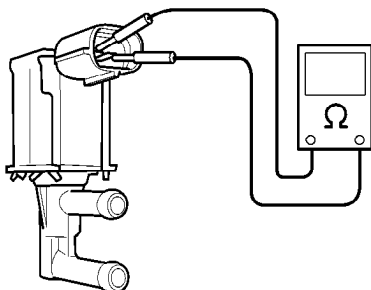

DTC P0480 RADIATOR FAN CONTROL CIRCUIT MALFUNCTION

CIRCUIT DESCRIPTION

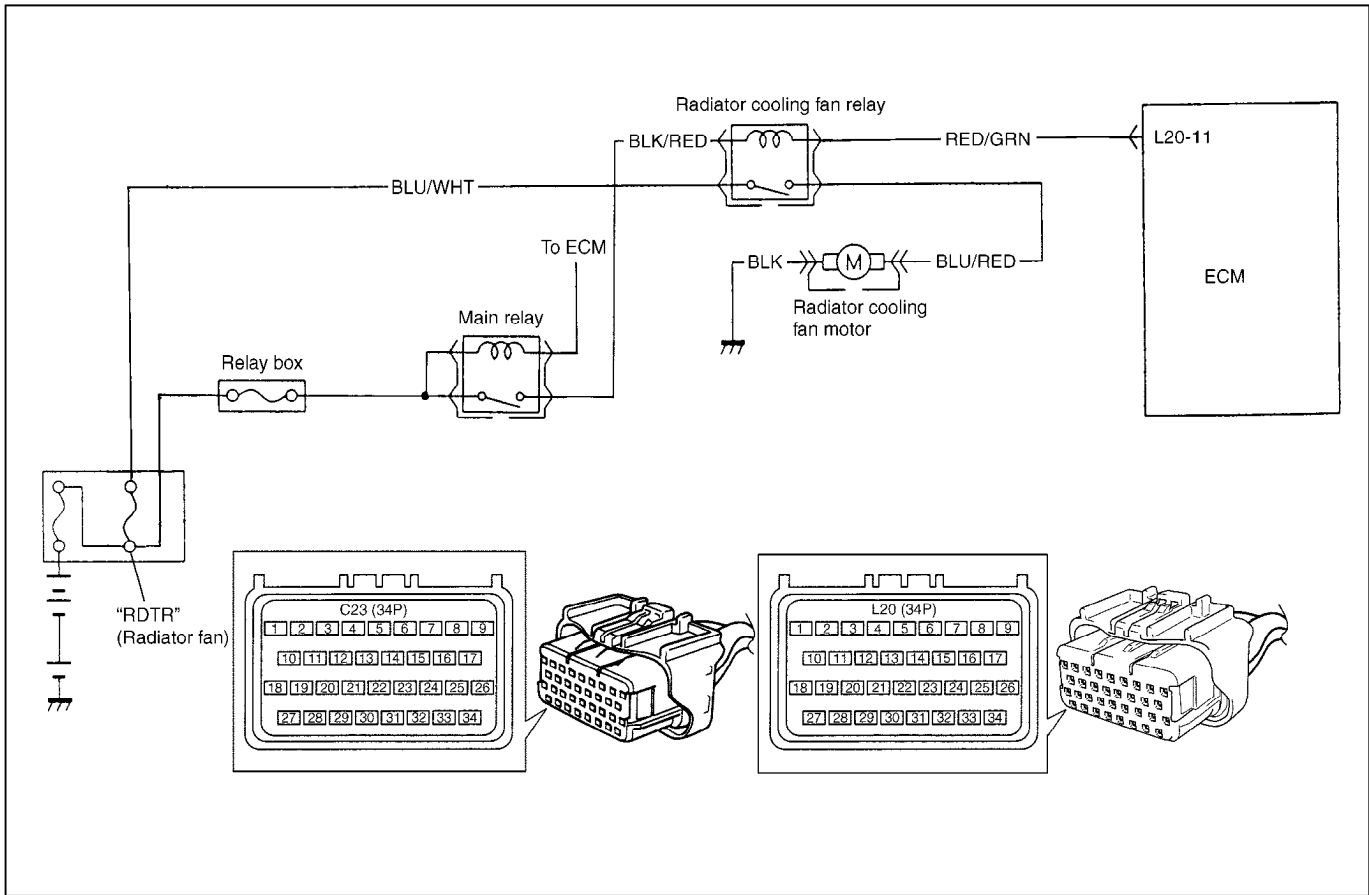

DTC DETECTING CONDITION	POSSIBLE CAUSE
<ul style="list-style-type: none"> ● Low voltage at terminal L20-11 when engine coolant temp. is below 85°C, 185°F. <p>* 2 driving cycle detection logic, continuous monitoring.</p>	<ul style="list-style-type: none"> ● "RED/GRN" or "BLK/RED" circuit open or short ● Radiator fan motor relay malfunction ● ECM malfunction

DTC CONFIRMATION PROCEDURE

- 1) Turn ignition switch OFF.
- 2) Clear DTC with ignition switch ON.
- 3) Warm up engine until radiator cooling fan starts to operate.
- 4) Check pending DTC in "PENDING DTC" mode and DTC in "DTC" mode.

DTC P0480**INSPECTION**

STEP	ACTION	YES	NO
1	Was "ENGINE DIAG. FLOW TABLE" performed?	Go to Step 2.	Go to "ENGINE DIAG. FLOW TABLE".
2	1) With ignition switch OFF position, install SUZUKI scan tool. 2) Start engine and run it at idle. 3) Observe engine coolant temperature on scan tool. Does cooling fan turn ON when engine coolant temperature reaches above 90°C (194°F)?	Radiator fan control system is functioning normally.	Go to Step3.
3	1) Stop engine. 2) With ignition switch OFF position, disconnect radiator fan relay. 3) Inspect radiator fan relay. Refer to "Main Relay/Fuel Pump Relay/Radiator Fan Relay Inspection" in Section 6E. Is radiator fan relay functioning normally?	Go to Step 4.	Faulty radiator fan relay.
4	1) Turn ignition switch ON position, leaving engine OFF. 2) Measure voltage from "a" of radiator fan relay connector to ground, from "c" of radiator fan relay connector to ground. See Fig.1. Is each voltage within 10-14V?	Go to Step 5.	Faulty "BLU/WHT", "BLK/RED" wire.
5	1) Turn ignition switch OFF position. 2) Connect jumper wire between "a" and "b" of radiator fan relay connector. See Fig.2. Does cooling fan turn ON when ignition switch turns ON position, leaving engine OFF?	Faulty "RED/GRN" wire. If wire and connection are OK, substitute a known-good ECM and recheck.	Faulty "BLU/RED", "BLK" wire. Faulty radiator fan motor. Poor connection.

Fig. 1 for Step 4

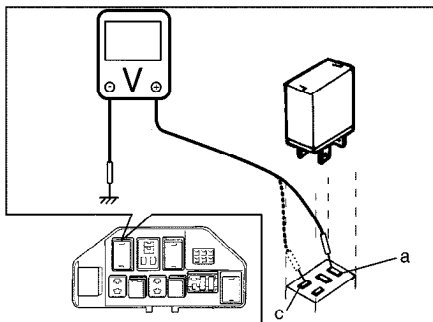
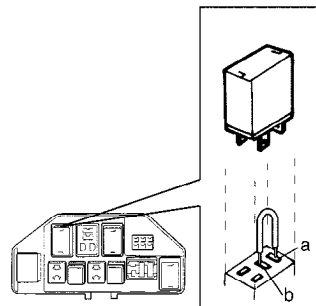
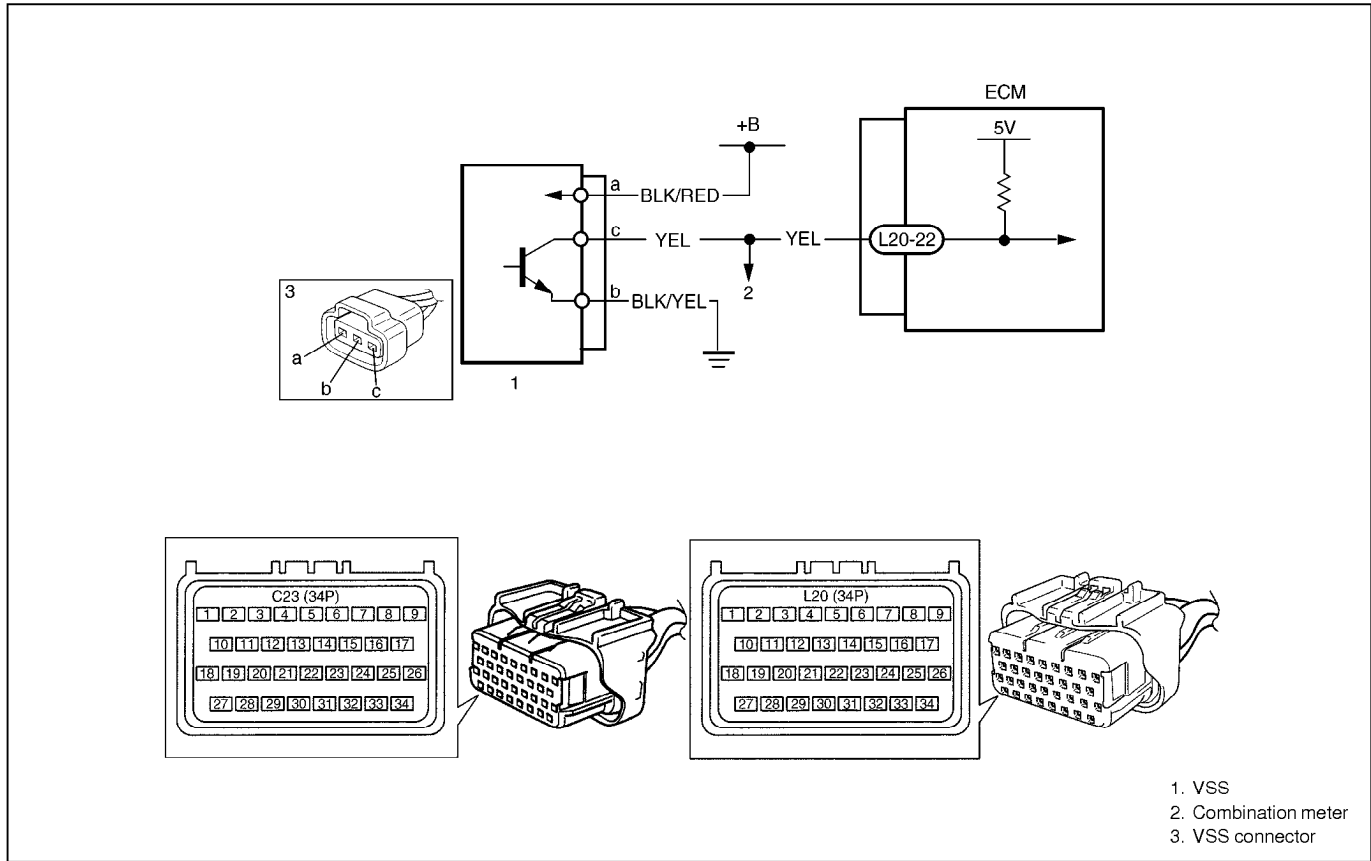

Fig. 2 for Step 5



DTC P0500 VEHICLE SPEED SENSOR (VSS) MALFUNCTION (DTC No.16)

CIRCUIT DESCRIPTION



DTC DETECTING CONDITION	POSSIBLE CAUSE
<ul style="list-style-type: none"> ● VSS signal not inputted while vehicle running during fuel cut at deceleration. ※ 2 driving cycle detection logic, continuous monitoring 	<ul style="list-style-type: none"> ● “BLK/YEL” circuit open ● “YEL” or “BLK/RED” circuit open or short ● VSS malfunction ● ECM malfunction ● Speedometer malfunction

DTC CONFIRMATION PROCEDURE

WARNING:

- When performing a road test, select a place where there is no traffic or possibility of a traffic accident and be very careful during testing to avoid occurrence of an accident.
- Road test should be carried out with 2 persons, a driver and a tester.

- 1) Clear DTC and warm up engine to normal operating temperature.
- 2) Increase vehicle speed to 50 mph, 80 km/h in 3rd gear while observing vehicle speed displayed on scan tool.
- 3) Release accelerator pedal and with engine brake applied, keep vehicle coasting (fuel cut condition) for 4 sec. or more.
- 4) Check pending DTC and DTC.

DTC P0500**INSPECTION**

STEP	ACTION	YES	NO
1	Was "ENGINE DIAG. FLOW TABLE" performed?	Go to Step 2.	Go to "ENGINE DIAG. FLOW TABLE".
2	Does speedometer indicate vehicle speed?	Go to Step 3.	Go to Step 4.
3	Check Vehicle Speed Signal. Is vehicle speed displayed on scan tool in step 2) and 3) of DTC confirmation procedure?	Intermittent trouble or faulty ECM. Check for intermittent referring to "Intermittent and Poor Connection" in Section 0A.	"YEL" wire open or short. Poor connection of ECM connector terminal. If OK, substitute a known-good ECM and recheck.
4	1) With ignition switch at OFF position, disconnect VSS connector. 2) Turn ignition switch to ON position, without running engine. 3) Measure voltage from terminal "a" to "b" of VSS connector. Is voltage within 10 – 14 V?	Go to Step 5.	"BLK/RED" or "BLK/YEL" wire open or short.
5	1) Measure voltage from terminal "c" of VSS connector to ground. Is voltage more than 4 V?	Go to Step 7.	Go to Step 6.
6	1) Measure voltage from terminal "a" of VSS connector to ground. Is voltage 4 – 6 V?	Substitute a known-good speedometer and recheck.	"YEL" wire open or short. Poor connection of ECM connector terminal. If OK, substitute a known-good ECM and recheck.
7	1) Remove VSS. 2) Visually inspect VSS sensor signal rotor for damage. Was any damage found?	Faulty VSS signal rotor.	Poor connection of VSS connector terminal. If OK, substitute a known-good VSS and recheck.

Fig. 1 for Step 4

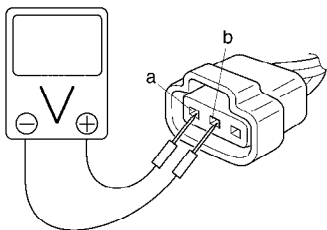
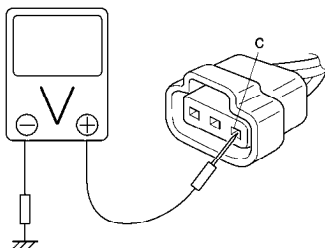
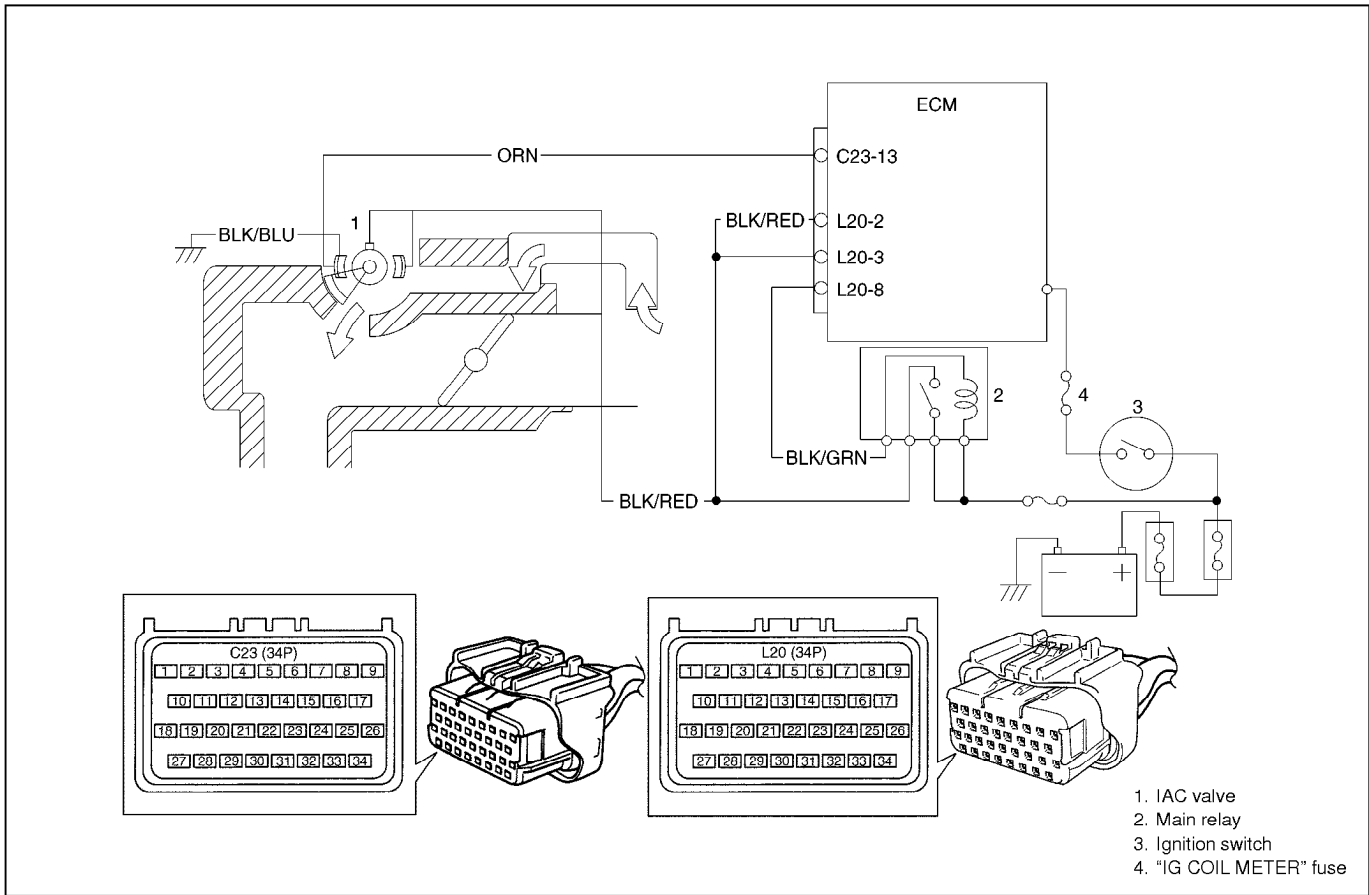

Fig. 2 for Step 5



DTC P0505 IDLE CONTROL SYSTEM MALFUNCTION

CIRCUIT DESCRIPTION



DTC DETECTING CONDITION	POSSIBLE CAUSE
<ul style="list-style-type: none"> ● No closed signal to IAC valve is detected after engine start. ※ 2 driving cycle detection logic, continuous monitoring. 	<ul style="list-style-type: none"> ● "BLK/RED", "ORN" or "BLK/BLU" circuit open or short ● IAC valve malfunction ● ECM malfunction

DTC CONFIRMATION PROCEDURE

- 1) Turn ignition switch OFF.
- 2) Clear DTC with ignition switch ON.
- 3) Start engine and run it at idle for 1 min.
- 4) Check DTC and pending DTC.

DTC P0505**INSPECTION**

STEP	ACTION	YES	NO
1	Was "ENGINE DIAG. FLOW TABLE" performed?	Go to Step 2.	Go to "ENGINE DIAG. FLOW TABLE".
2	<p>Check Idle Air Control System.</p> <p>When using SUZUKI scan tool:</p> <ol style="list-style-type: none"> 1) Connect SUZUKI scan tool to DLC with ignition switch OFF, set parking brake and block drive wheels. 2) Warm up engine to normal operating temperature. 3) Clear DTC and select "MISC TEST" mode on SUZUKI scan tool. <p>Is it possible to control (increase and reduce) engine idle speed by using SUZUKI scan tool?</p> <p>When not using SUZUKI scan tool:</p> <ol style="list-style-type: none"> 1) Remove IAC valve from throttle body referring to "IAC Valve Removal" in Section 6E. 2) Check IAC valve for operation referring to "IAC Valve Inspection" in Section 6E. See Fig. 1. <p>Is check result satisfactory?</p>	<p>Intermittent trouble or faulty ECM.</p> <p>Check for intermittent referring to "Intermittent and Poor Connection" in Section 0A.</p>	Go to Step 3.
3	<p>Check Wire Harness for Open and Short.</p> <ol style="list-style-type: none"> 1) Turn ignition switch OFF. 2) Disconnect IAC valve connector. 3) Check for proper connection to IAC valve at each terminals. 4) If OK, disconnect ECM connector. 5) Check for proper connection to ECM at C23-13 terminal. 6) If OK, check "BLK/RED", "ORN" and "BLK/BLU" circuit for open and short. <p>Are they in good condition?</p>	Replace IAC valve and recheck.	Repair or replace.

Fig. 1 for Step 2

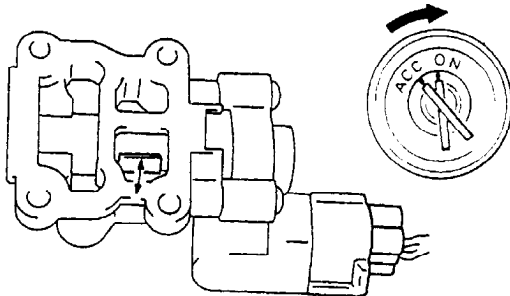

DTC P1450 BAROMETRIC PRESSURE SENSOR LOW/HIGH INPUT**DTC P1451 BAROMETRIC PRESSURE SENSOR PERFORMANCE PROBLEM****WIRING DIAGRAM/CIRCUIT DESCRIPTION**

Barometric pressure sensor is installed in ECM.

DTC DETECTING CONDITION	POSSIBLE CAUSE
DTC P1450: ● Barometric pressure sensor voltage is 4.7 V or higher, or 1.6 V or lower	● ECM (barometric pressure sensor) malfunction
DTC P1451: ● Vehicle stopped ● Engine cranking ● Difference between barometric pressure and intake manifold absolute pressure is 26 kPa, 200 mmHg or more. ● Difference between intake manifold absolute pressure at engine start and pressure after engine start is less than 1.3 kPa, 10 mmHg. ※ 2 driving cycle detection logic, monitoring once/1 driving.	● ECM (barometric pressure sensor) malfunction

DTC CONFIRMATION PROCEDURE

- 1) Turn ignition switch OFF.
- 2) Clear DTC with ignition switch ON.
- 3) Turn ignition switch ON for 2 sec., crank engine for 2 sec. and run it at idle for 1 min.
- 4) Check pending DTC in "PENDING DTC" mode and DTC in "DTC" mode.

INSPECTION**DTC P1450:**

Substitute a known-good ECM and recheck.

DTC P1451:**NOTE:**

Note that atmospheric pressure varies depending on weather conditions as well as altitude.

Take that into consideration when performing these check.

STEP	ACTION	YES	NO
1	Was "ENGINE DIAG. FLOW TABLE" performed?	Go to Step 2.	Go to "ENGINE DIAG. FLOW TABLE" in this section.
2	1) Connect scan tool to DLC with ignition switch OFF. 2) Turn ignition switch ON and select "DATA LIST" mode on scan tool. 3) Check manifold absolute pressure. Is it barometric pressure (approx. 100 kPa, 760 mmHg) at sea level?	Substitute a known-good ECM and recheck.	Go to Step 3.

STEP	ACTION	YES	NO								
3	<p>Check MAP Sensor</p> <p>1) Remove MAP sensor from intake manifold and connect vacuum pump gauge to MAP sensor. See Fig. 1.</p> <p>2) Connect scan tool to DLC and turn ignition switch ON.</p> <p>3) Check intake manifold absolute pressure displayed on scan tool under following conditions.</p> <table border="1" data-bbox="305 407 977 728"> <thead> <tr> <th data-bbox="305 407 581 457">Applying Vacuum</th> <th data-bbox="581 407 977 457">Displayed Value on Scan Tool</th> </tr> </thead> <tbody> <tr> <td data-bbox="305 457 581 548">0</td> <td data-bbox="581 457 977 548">Barometric pressure (Approx. 100 kPa, 760 mmHg)</td> </tr> <tr> <td data-bbox="305 548 581 638">27 kPa 200 mmHg</td> <td data-bbox="581 548 977 638">Barometric pressure -27 kPa (Approx. 73 kPa, 560 mmHg)</td> </tr> <tr> <td data-bbox="305 638 581 728">67 kPa 500 mmHg</td> <td data-bbox="581 638 977 728">Barometric pressure -67 kPa (Approx. 33 kPa, 260 mmHg)</td> </tr> </tbody> </table> <p>Is check result satisfactory?</p>	Applying Vacuum	Displayed Value on Scan Tool	0	Barometric pressure (Approx. 100 kPa, 760 mmHg)	27 kPa 200 mmHg	Barometric pressure -27 kPa (Approx. 73 kPa, 560 mmHg)	67 kPa 500 mmHg	Barometric pressure -67 kPa (Approx. 33 kPa, 260 mmHg)	<p>Check air intake system for air being drawn in and engine compression. If OK, then substitute a known-good ECM and recheck.</p>	<p>Replace MAP sensor.</p>
Applying Vacuum	Displayed Value on Scan Tool										
0	Barometric pressure (Approx. 100 kPa, 760 mmHg)										
27 kPa 200 mmHg	Barometric pressure -27 kPa (Approx. 73 kPa, 560 mmHg)										
67 kPa 500 mmHg	Barometric pressure -67 kPa (Approx. 33 kPa, 260 mmHg)										

Fig. 1 for Step 2

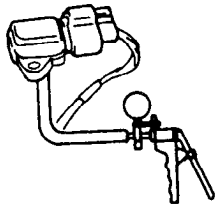

DTC P1500 ENGINE STARTER SIGNAL CIRCUIT MALFUNCTION

CIRCUIT DESCRIPTION

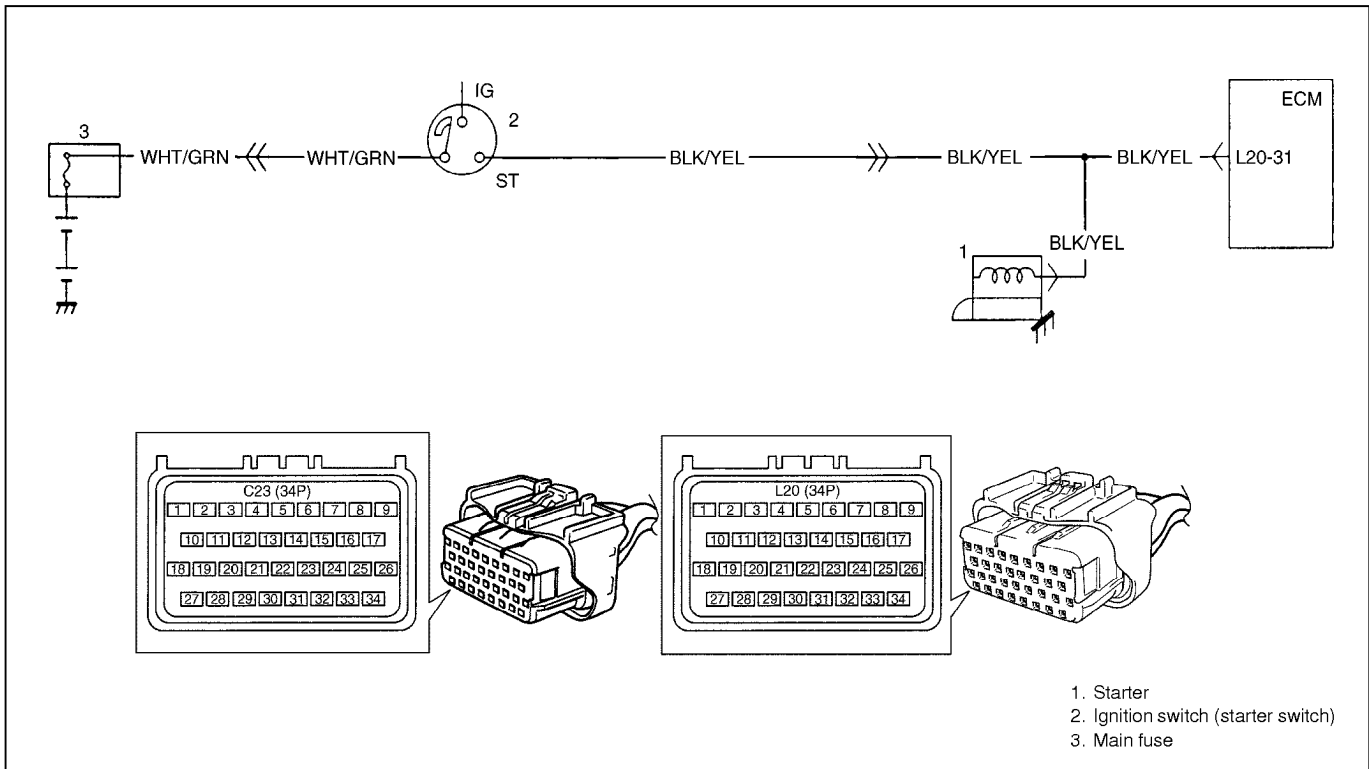

DTC DETECTING CONDITION	POSSIBLE CAUSE
<ul style="list-style-type: none"> ● Low voltage at terminal L20-31 when cranking engine or ● High voltage at terminal L20-31 after starting engine. * 2 driving cycle detection logic, continuous monitoring.	<ul style="list-style-type: none"> ● "BLK/YEL" circuit open ● ECM malfunction

DTC CONFIRMATION PROCEDURE

- 1) Turn ignition switch OFF.
- 2) Clear DTC with ignition switch ON, crank engine and run it at idle for 3 min.
- 3) Check pending DTC in "PENDING DTC" mode and DTC in "DTC" mode.

INSPECTION

STEP	ACTION	YES	NO
1	Was "ENGINE DIAG. FLOW TABLE" performed?	Go to Step 2.	Go to "ENGINE DIAG. FLOW TABLE".
2	Check for voltage at terminal L20-31 of ECM connector disconnected, under following condition. While engine cranking : 6 – 10 V Ignition switch at ON position : 0 V Is voltage as specified?	Poor L20-31 connection or intermittent trouble. Check for intermittent referring to "Intermittent and Poor Connection" in Section 0A. If wire and connections are OK, substitute a known-good ECM and recheck.	"BLK/YEL" circuit open.

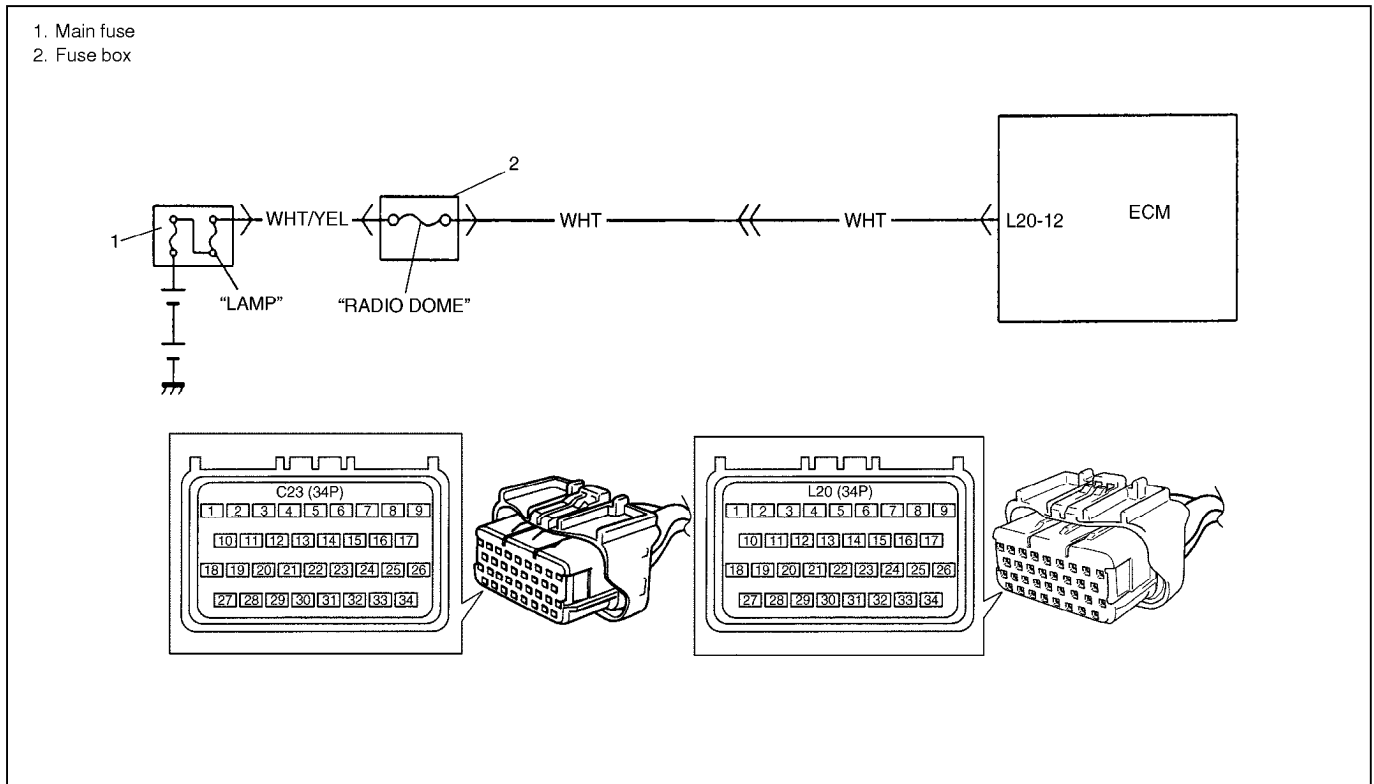
DTC P1510 ECM BACK-UP POWER SUPPLY MALFUNCTION**CIRCUIT DESCRIPTION**

Battery voltage is supplied so that diagnostic trouble code memory, values for engine control learned by ECM, etc. are kept in ECM even when the ignition switch is turned OFF.

DTC DETECTING CONDITION	POSSIBLE CAUSE
<ul style="list-style-type: none"> • Low voltage at terminal L20-12 after starting engine. 	<ul style="list-style-type: none"> • "WHT" circuit open • ECM malfunction

DTC CONFIRMATION PROCEDURE

- 1) Clear DTC, start engine and run it at idle for 1 min.
- 2) Select "DTC" mode on scan tool and check DTC.

INSPECTION

STEP	ACTION	YES	NO
1	Was "ENGINE DIAG. FLOW TABLE" performed?	Go to Step 2.	Go to "ENGINE DIAG. FLOW TABLE".
2	Check for voltage at terminal L20-12 of ECM connector disconnected with ignition switch OFF. Is it 10 – 14 V?	Poor L20-12 connection or intermittent trouble. Check for intermittent referring to "Intermittent and Poor Connection" in Section 0A. If wire and connections are OK, substitute a known- good ECM and recheck.	"WHT" circuit open.

TABLE B-1 FUEL INJECTOR CIRCUIT CHECK

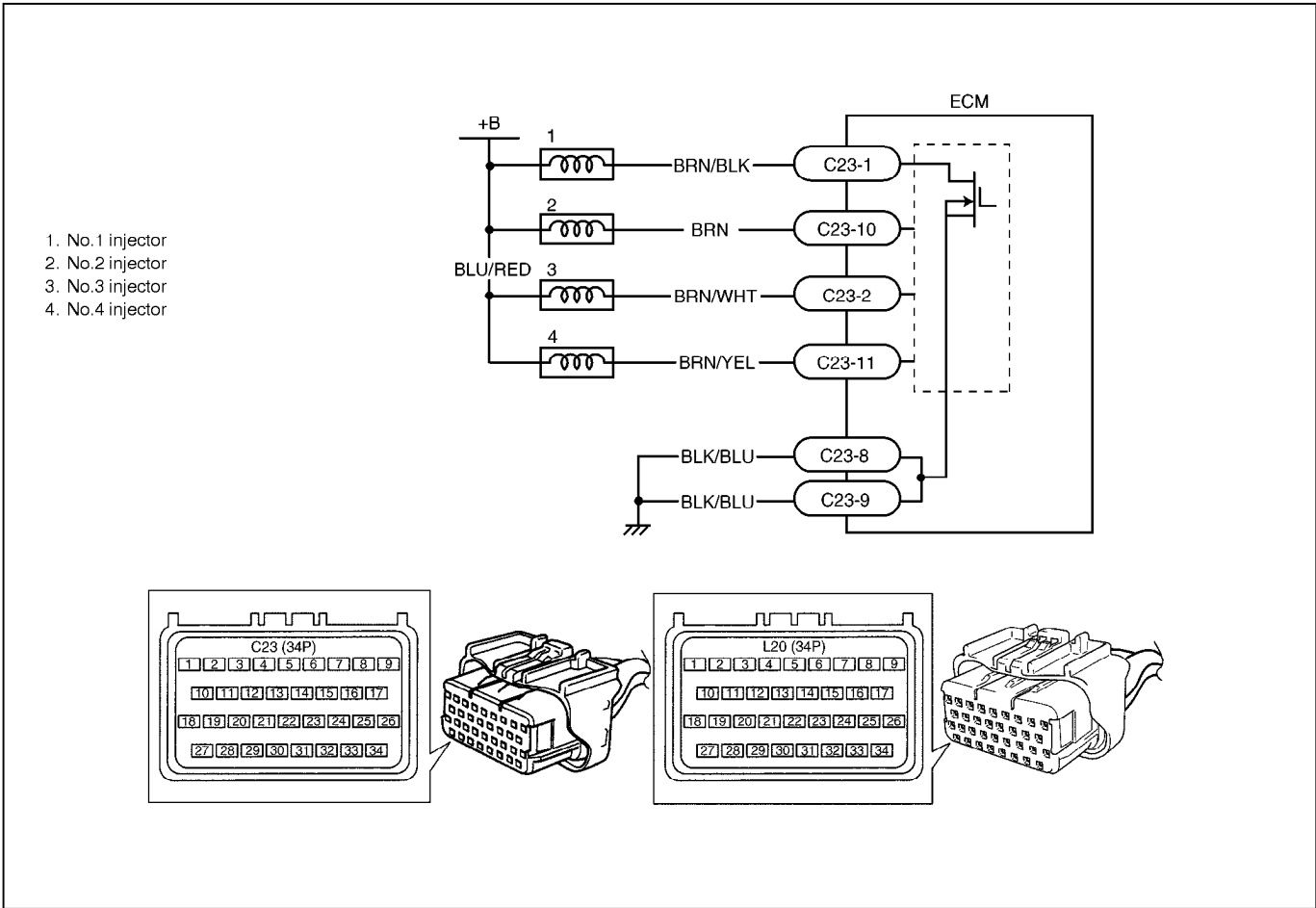

INSPECTION

STEP	ACTION	YES	NO
1	Was "ENGINE DIAG. FLOW TABLE" performed?	Go to Step 2.	Go to "ENGINE DIAG. FLOW TABLE".
2	Check Injector for Operating Sound. Using sound scope, check each injector for operating sound at engine cranking. Do all 4 injector make operating sound?	Fuel injector circuit is in good condition.	Go to Step 3.
3	Dose none of 4 injectors make operating sound at Step 2?	Go to Step 4.	Check coupler connection and wire harness of injector not making operating sound and injector itself (Refer to Section 6E).
4	Check power circuit of injectors for open and short. Is it normal?	Check all 4 injectors for resistance respectively. If resistance is OK, substitute a known-good ECM and recheck.	Power circuit open or short.

TABLE B-2 FUEL PUMP AND ITS CIRCUIT CHECK

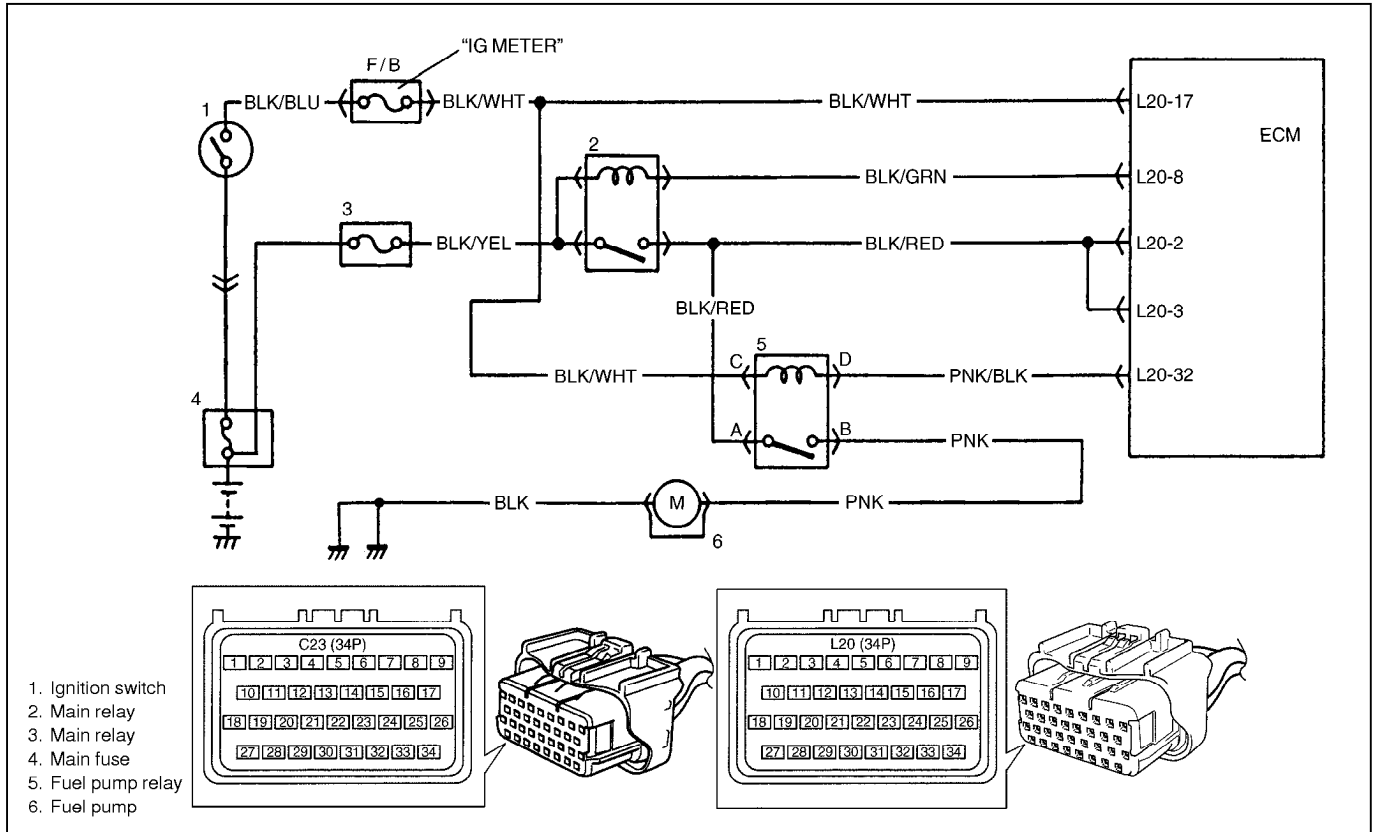

INSPECTION

STEP	ACTION	YES	NO
1	Was "ENGINE DIAG. FLOW TABLE" performed?	Go to Step 2.	Go to "ENGINE DIAG. FLOW TABLE".
2	Check Fuel Pump Control System for Operation. See Fig. 1. Is fuel pump heard to operate for 2 sec. after ignition switch ON?	Fuel pump circuit is in good condition.	Go to Step 3.
3	Check Fuel Pump for Operation. 1) Remove fuel pump relay from relay box with ignition switch OFF. 2) Check for proper connection to relay at each terminals. 3) If OK, using service wire, connect terminals "A" and "B" of relay connector. See Fig. 2. <div style="border: 1px solid black; padding: 5px; margin: 10px 0;"> CAUTION: Check to make sure that connection is made between correct terminals. Wrong connection can cause damage to ECM, wire harness, etc. </div> Is fuel pump heard to operate at ignition switch ON?	Go to Step 4.	"PNK", "BLK" or "BLK/RED" circuit open or fuel pump malfunction.
4	Check Fuel Pump Relay for Operation. 1) Check resistance between each two terminals of fuel pump relay. See Fig.3. Between terminals "A" and "B": Infinity Between terminals "C" and "D": 56 – 146 Ω 2) Check that there is continuity between terminals "A" and "B" when battery is connected to terminals "C" and "D". See Fig. 3. Is fuel pump relay in good condition?	"PNK/BLK" circuit open or poor L20-32 connection. If wire and connection are OK, substitute a known-good ECM and recheck.	Replace fuel pump relay.

Fig. 1 for Step 2

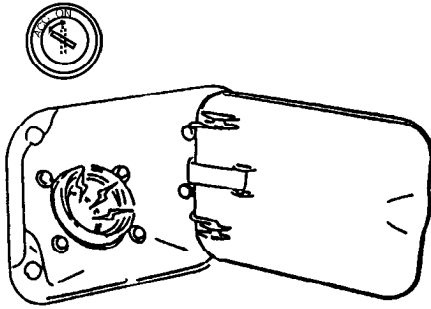

Fig. 2 for Step 3

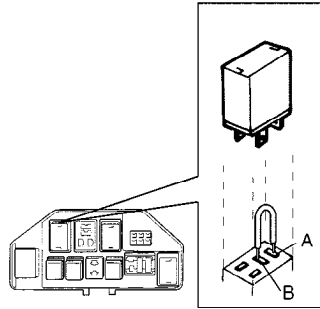

Fig. 3 for Step 4

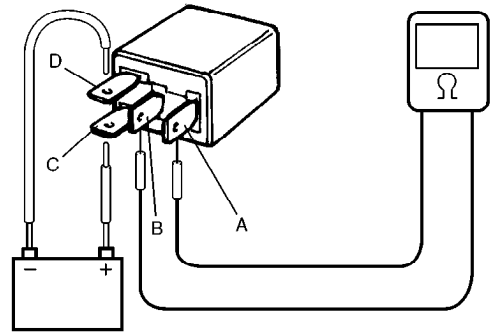
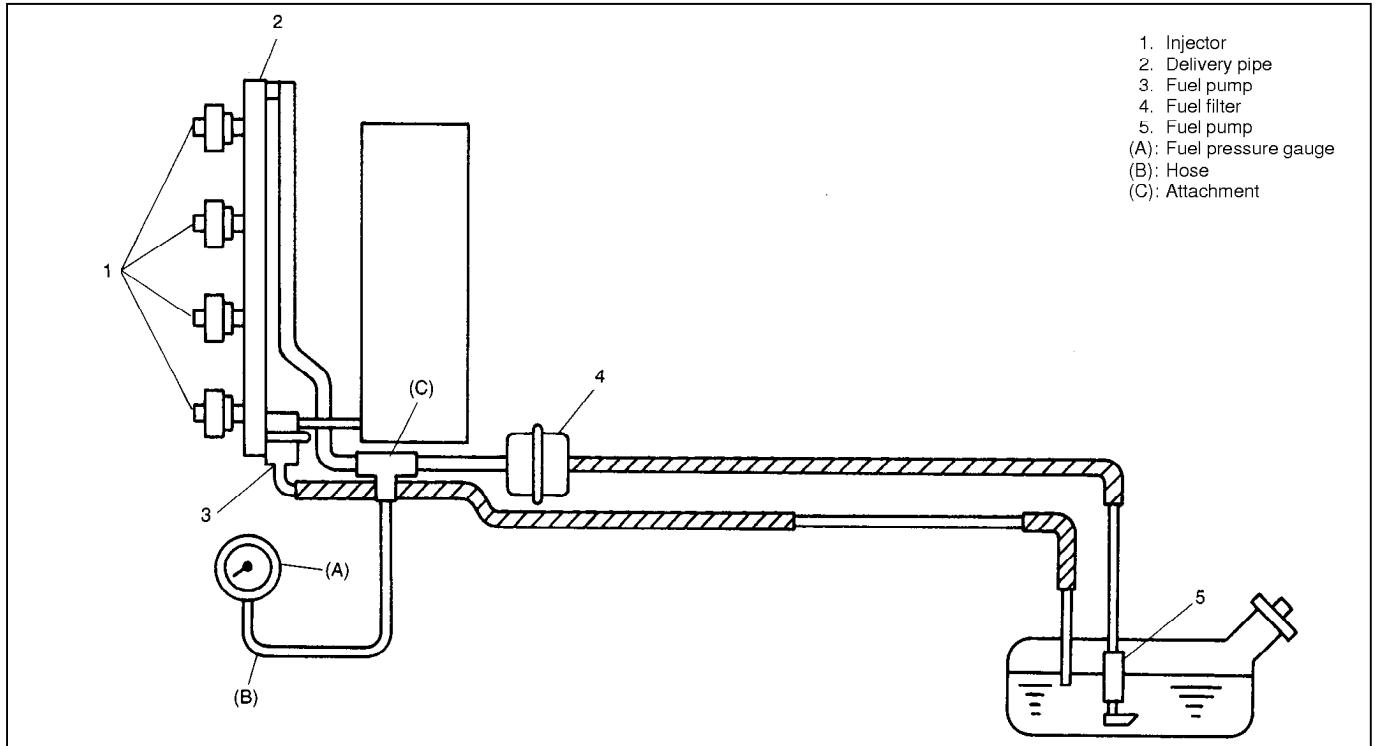

TABLE B-3 FUEL PRESSURE CHECK



INSPECTION

STEP	ACTION	YES	NO
1	Check Fuel Pressure (Refer to Section 6E for details). 1) Release fuel pressure from fuel feed line. 2) Install fuel pressure gauge. 3) Check fuel pressure by repeating ignition switch ON and OFF. See Fig. 1. Is fuel pressure then 270 – 310 kPa (2.7 – 3.1 kg/cm ² , 38.4 – 44.0 psi)?	Go to Step 2.	Go to Step 4.
2	Is 200 kPa (2.0 kg/cm ² , 28.4 psi) or higher fuel pressure retained for 1 minute after fuel pump is stopped at Step 1?	Normal fuel pressure.	Go to Step 3.
3	Is there fuel leakage from fuel feed line hose, pipe or their joint?	Fuel leakage from hose, pipe or joint.	Faulty fuel pressure regulator.
4	Was fuel pressure higher than spec. in Step 1?	Faulty fuel pressure regulator. Faulty fuel pressure control valve.	Clogged fuel filter, Restricted fuel feed hose or pipe, Faulty fuel pump or Fuel leakage from hose connection in fuel tank.

Fig. 1 for Step 1

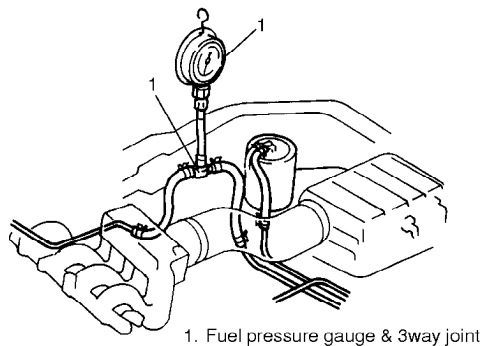
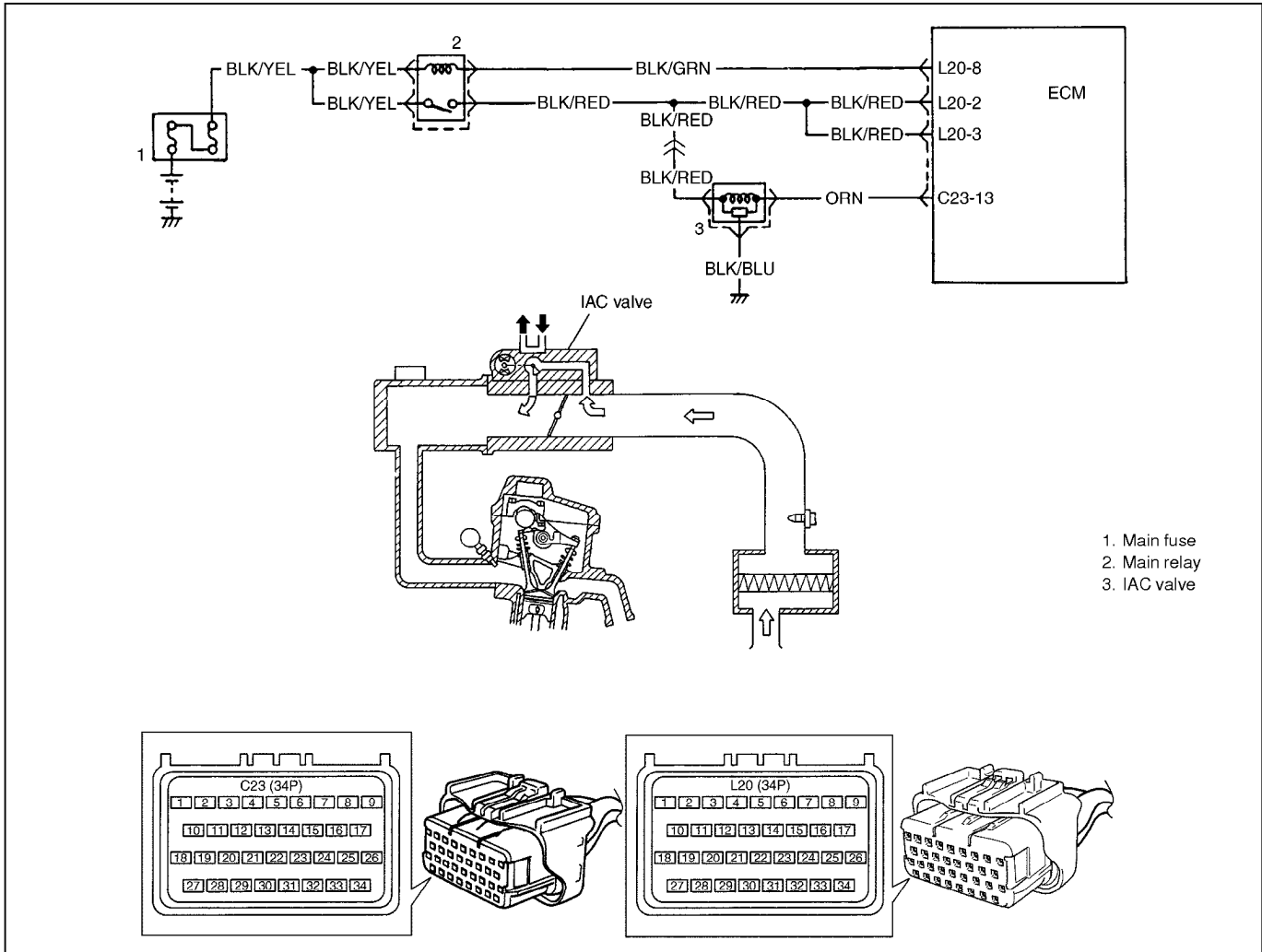

TABLE B-4 IDLE AIR CONTROL SYSTEM CHECK



INSPECTION

STEP	ACTION	YES	NO
1	Check engine idle speed and IAC duty referring to "Idle Speed/IAC Duty Inspection" in Section 6E. Is idle speed within specification?	Go to Step 2.	Go to Step 4.
2	Is IAC duty within specification in Step 1?	Go to Step 3.	Check for followings: - Vacuum leak - EVAP canister purge control system - Clog of IAC air passage - Accessory engine load - Closed throttle position (TP sensor) - Stuck of PCV valve
3	Is engine idle speed kept specified speed even with headlight ON?	System is in good condition.	Check IAC system for operation referring to Step 2 of DTC P0505 Diag. Flow Table.
4	Was idle speed higher than specification in Step 1?	Go to Step 5.	Go to Step 8.
5	Check A/C (input) signal circuit referring to Step 1 of Table B-5 A/C Signal Circuit Check, if equipped. (A/C signal can be also checked by using SUZUKI scan tool.) Is it in good condition?	Go to Step 6.	Repair or replace A/C signal circuit or A/C system.

STEP	ACTION	YES	NO
6	Check IAC system referring to Step 2 of DTC P0505 Diag. Flow Table. Is check result satisfactory?	Go to Step 7.	Go to Step 3 of DTC P0505 Diag. Flow Table.
7	Was IAC duty less than about 3% (or more than about 97% for OFF duty meter) in Step 1 of this table?	Check abnormal air inhaling from air intake system, PCV valve and EVAP canister purge control system.	Check TP sensor (closed throttle position) and ECT sensor for performance. If sensors are OK, substitute a known-good ECM.
8	Check IAC system referring to Step 2 of DTC P0505 Diag. Flow Table. Is check result satisfactory?	Go to Step 9.	Go to Step 3 of DTC P0505 Diag. Flow Table.
9	Was IAC duty more than about 30% or *40% (or less than 70% or *60% for OFF duty meter) in Step 1 of this table? NOTE: Duty value with (*) are applicable to vehicle used at high altitude (higher than 2000 m or 6560 ft).	Check parts or system which can cause engine low idle. – Accessory engine load – Clog of air passage – Etc.	Substitute a known-good ECM and recheck.

TABLE B-5 A/C SIGNAL CIRCUITS CHECK (VEHICLE WITH A/C)

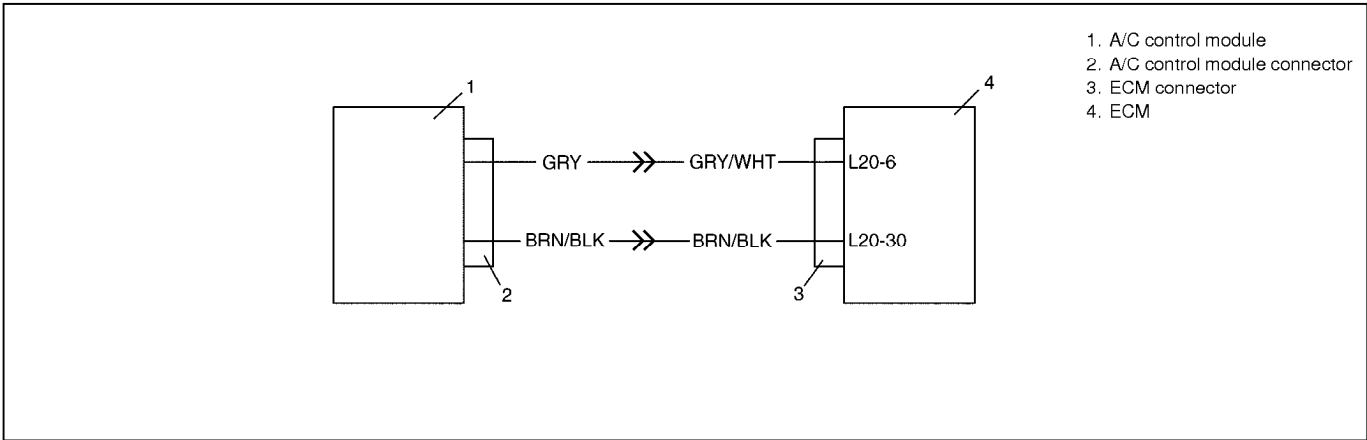

SYSTEM DESCRIPTION

A/C control module transmits "A/C signal" to ECM when A/C ON conditions are satisfied on the A/C control module side.

ECM transmits "A/C ON signal" to A/C control module when "A/C signal" inputted to ECM and A/C ON conditions are satisfied on the ECM side. Then, A/C is operated.

INSPECTION

STEP	ACTION	YES	NO
1	Did you perform "ENGINE DIAGNOSTIC FLOW TABLE" in Section 6?	Go to Step 2.	Go to "ENGINE DIAGNOSTIC FLOW TABLE".
2	Check A/C signal circuit. 1) Disconnect ECM connectors and A/C control module connector with ignition switch OFF. 2) Check "GRY", "GRY/WHT" and "BRN/BLK" wires for open or short. Are "GRY", "GRY/WHT" and "BRN/BLK" wires in good condition?	Intermittent trouble Check for intermittent referring to "Intermittent and Poor Connection" in Section 0A.	"GRY", "GRY/WHT" and "BRN/BLK" wire open or shorted to ground or poor connection at L20-6 and L20-30. Faulty A/C control module. If OK, substitute a known-good ECM and recheck.

TABLE B-6 ELECTRIC LOAD SIGNAL CIRCUIT CHECK

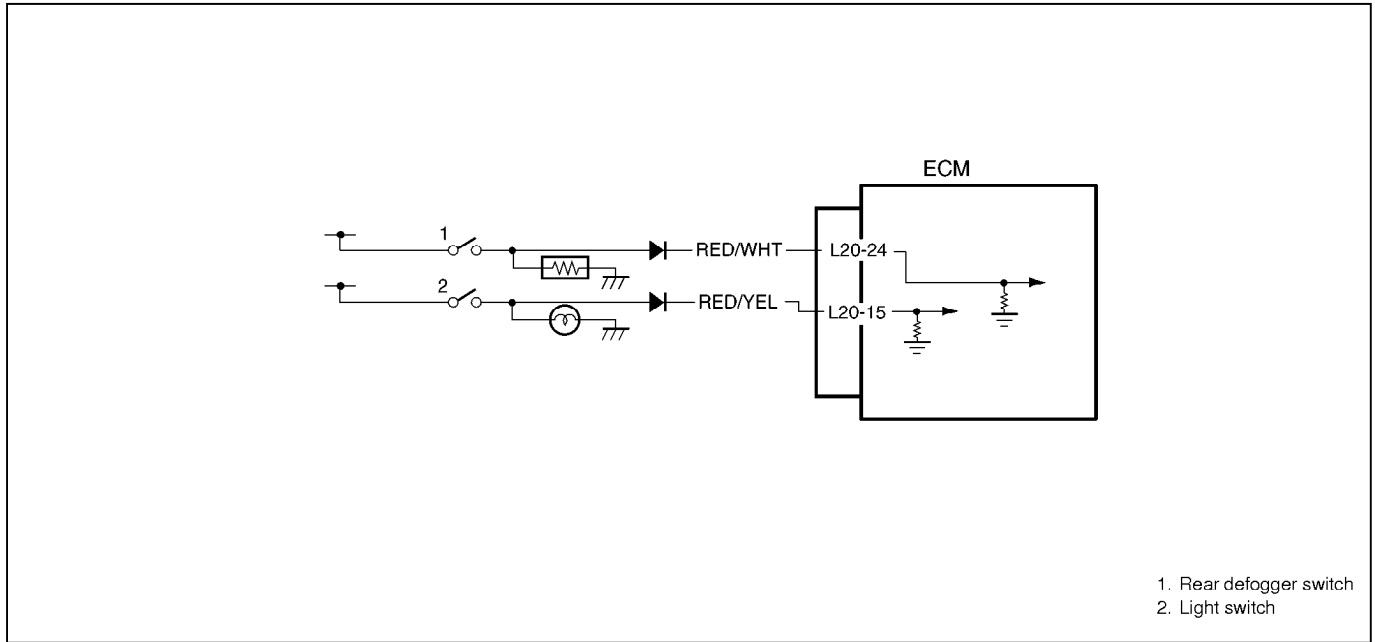

INSPECTION

STEP	ACTION	YES	NO
1	Check Electric Load Signal Circuit. 1) Connect SUZUKI scan tool to DLC with ignition switch OFF. 2) Start engine and select "DATA LIST" mode on scan tool. 3) Check electric load signal under following each condition. Ignition switch ON, Small light and rear defogger all turned OFF : OFF Ignition switch ON, Small light or rear defogger turned ON : ON Is check result satisfactory?	Electric load signal circuit is in good condition.	"RED/WHT" and/or "RED/YEL" circuit open or short, Electric load diodes malfunction or Each electric load circuit malfunction.

TABLE B-7 RADIATOR FAN CONTROL SYSTEM CHECK

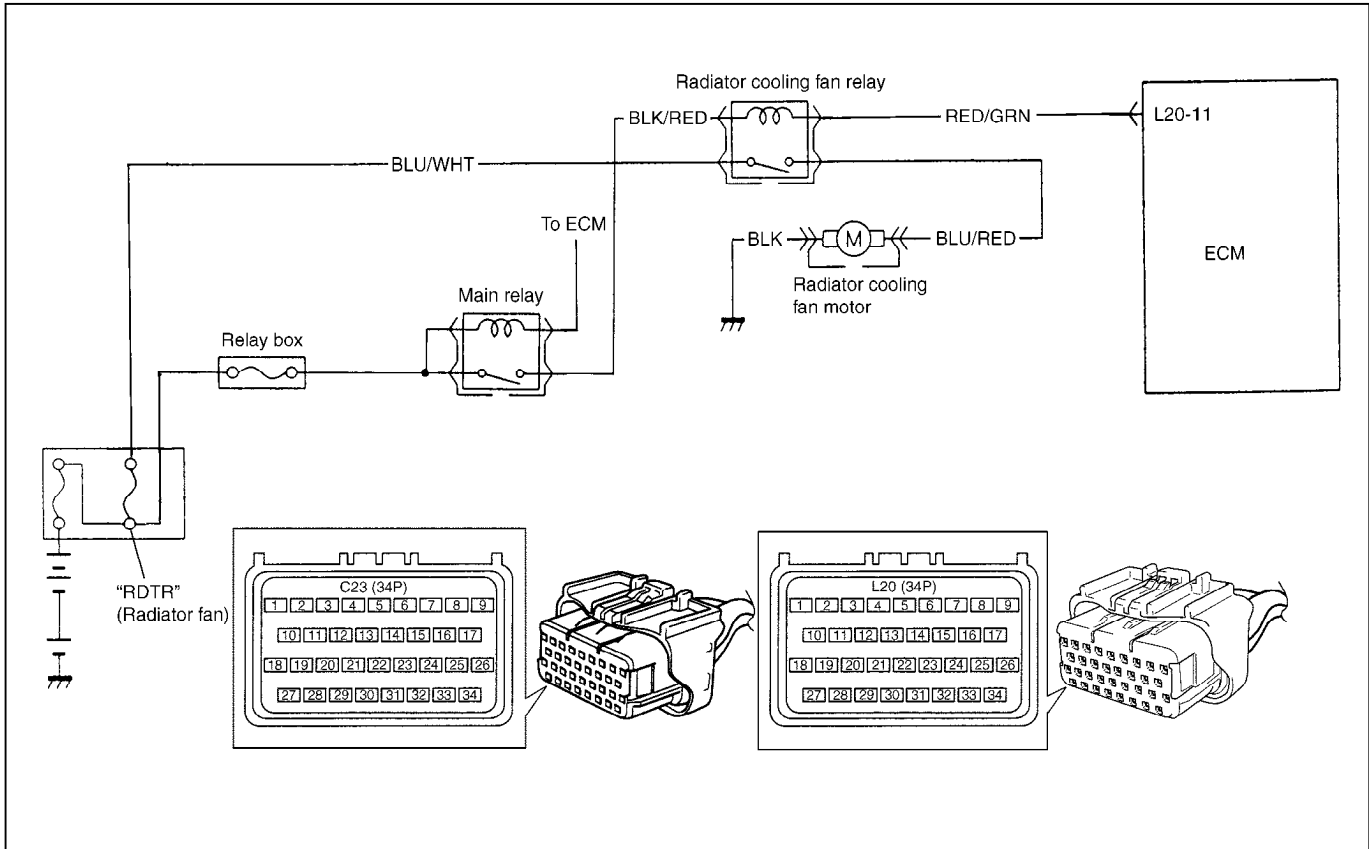

INSPECTION

STEP	ACTION	YES	NO
1	Check Fan Control System. 1) Connect scan tool to DLC with ignition switch OFF. 2) Start engine and select "DATA LIST" mode on scan tool. 3) Warm up engine until coolant temp. is 90°C, 194°F or higher and A/C switch turn OFF. (If engine coolant temp. does not rise, check engine cooling system or ECT sensor.) Is radiator fan started when engine coolant temp. reached above temp.?	Radiator fan control system is in good condition.	Go to Step 2.
2	Check radiator Fan Relay and Its Circuit. 1) Check DTC and pending DTC with scan tool. Is DTC P0480 displayed?	Go to DTC P0480 Diag. Flow Table.	Go to Step 3.
3	Check radiator Fan Relay. 1) Turn ignition switch OFF and remove radiator fan relay. 2) Check for proper connection to relay at terminals "A" and "B". 3) If OK, check that there is continuity between "A" and "B" when battery is connected to terminals "C" and "D". See Fig. 1. Is check result satisfactory?	Go to Step 4.	Replace radiator fan relay.
4	Check Radiator Fan. 1) Turn ignition switch OFF. 2) Disconnect fan motor connector. 3) Check for proper connection to motor at "BLU/RED" and "BLK" terminals. 4) If OK, connect battery to motor and check for operation. See Fig. 2. Is it in good condition?	"BLU/WHT", "BLU/RED" or "BLK" circuit open.	Replace radiator fan motor.

Fig. 1 for Step 3

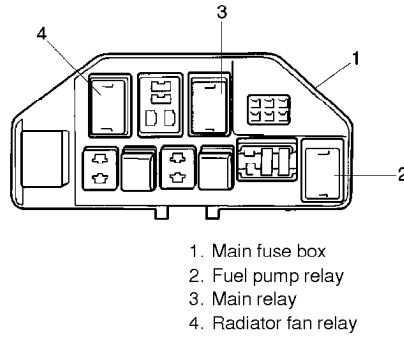
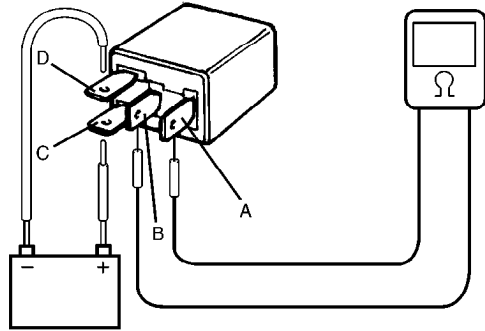

- 1. Main fuse box
- 2. Fuel pump relay
- 3. Main relay
- 4. Radiator fan relay

Fig. 2 for Step 4

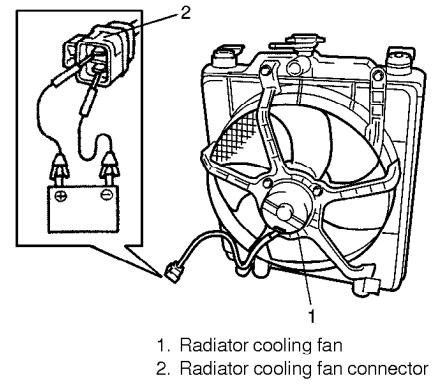

- 1. Radiator cooling fan
- 2. Radiator cooling fan connector

SPECIAL TOOLS

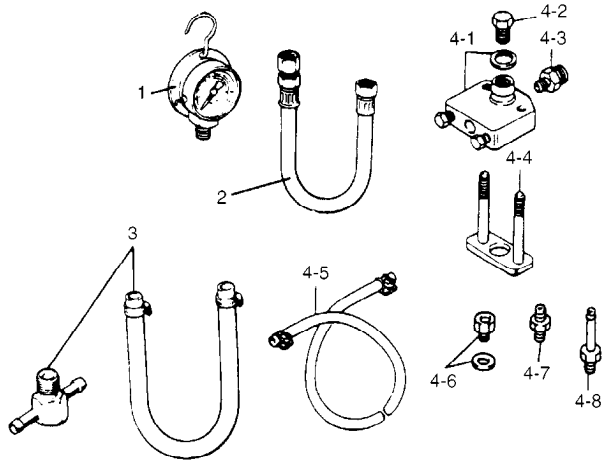

- 1. Pressure gauge
09912-58441
- 2. Pressure hose
09912-58431
- 3. 3-way joint & hose
09912-58490
- 4. Checking tool set
09912-58421
- 4-1. Tool body & washer
- 4-2. Body plug
- 4-3. Body attachment-1
- 4-4. Holder
- 4-5. Return hose & clamp
- 4-6. Body attachment-2 & washer
- 4-7. Hose attachment-1
- 4-8. Hose attachment-2

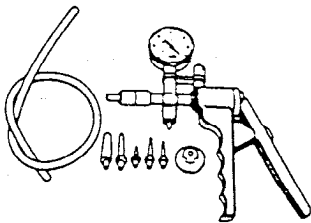

09917-47911
Vacuum pump gauge

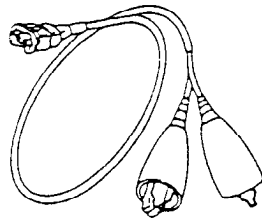

09930-88530
Injector test lead

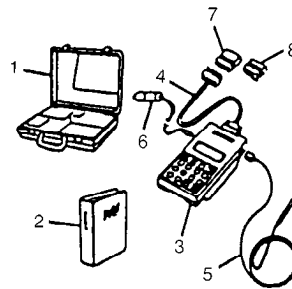

09931-76011
SUZUKI scan tool (Tech 1 A) kit

- 1. Storage case
- 2. Operator's manual
- 3. Tech 1 A
- 4. DLC cable (14/26 pin,
09931-76040)
- 5. Test lead/probe
- 6. Power source cable
- 7. DLC cable adaptor
- 8. Self-test adaptor

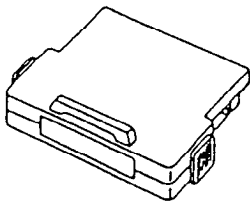

Mass storage cartridge

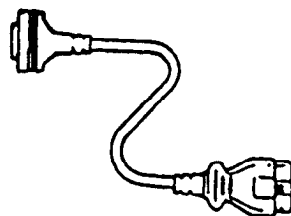

09931-76030
16/14 pin DLC cable

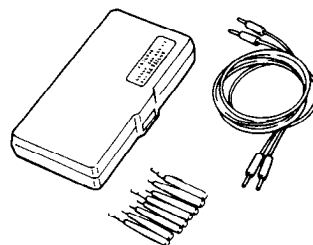

09932-76010
Connector test adapter kit

SECTION 6A

ENGINE MECHANICAL

WARNING:

For vehicles equipped with Supplemental Restraint (Air Bag) System:

- Service on and around the air bag system components or wiring must be performed only by an authorized SUZUKI dealer. Refer to AIR BAG SYSTEM COMPONENTS AND WIRING LOCATION VIEW of GENERAL DESCRIPTION in air bag system section in order to confirm whether you are performing service on or near the air bag system components or wiring. Please observe all WARNINGS and SERVICE PRECAUTIONS of ON-VEHICLE SERVICE in air bag system section before performing service on or around the air bag system components or wiring. Failure to follow WARNINGS could result in unintentional activation of the system or could render the system inoperative. Either of these two conditions may result in severe injury.
- Technical service work must be started at least 90 seconds after the ignition switch is turned to the LOCK position and negative cable is disconnected from the battery. Otherwise, the system may be activated by reserve energy in the Sensing and Diagnostic Module (SDM).

NOTE:

For the descriptions (items) not found in this section, refer to the same section of the Service Manual mentioned in the FOREWORD of this manual.

6A

CONTENTS

ON-VEHICLE SERVICE	6A- 2
ROCKER ARMS, ROCKER ARM SHAFT AND CAMSHAFT	6A- 2
UNIT REPAIR OVERHAUL	6A- 3
ENGINE ASSEMBLY	6A- 3
MAIN BEARINGS, CRANKSHAFT AND CYLINDER BLOCK	6A- 5

NOTE:

For what each abbreviation stands for (i.e., full term), refer to SECTION 0A.

ON-VEHICLE SERVICE

ROCKER ARMS, ROCKER ARM SHAFT AND CAMSHAFT

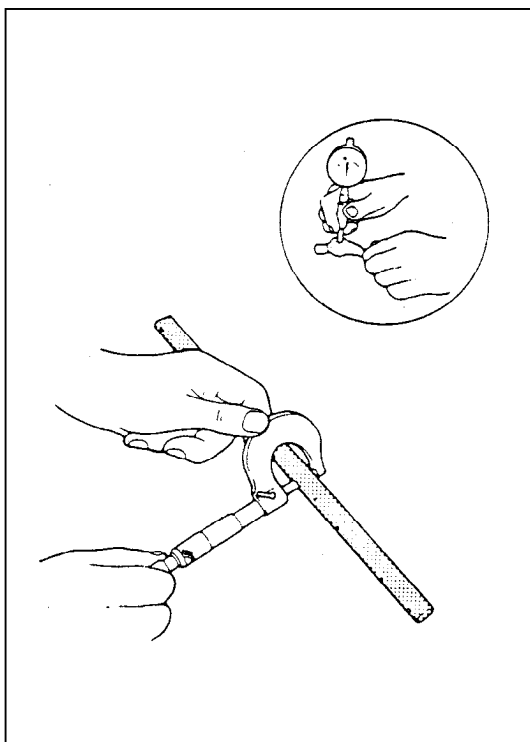
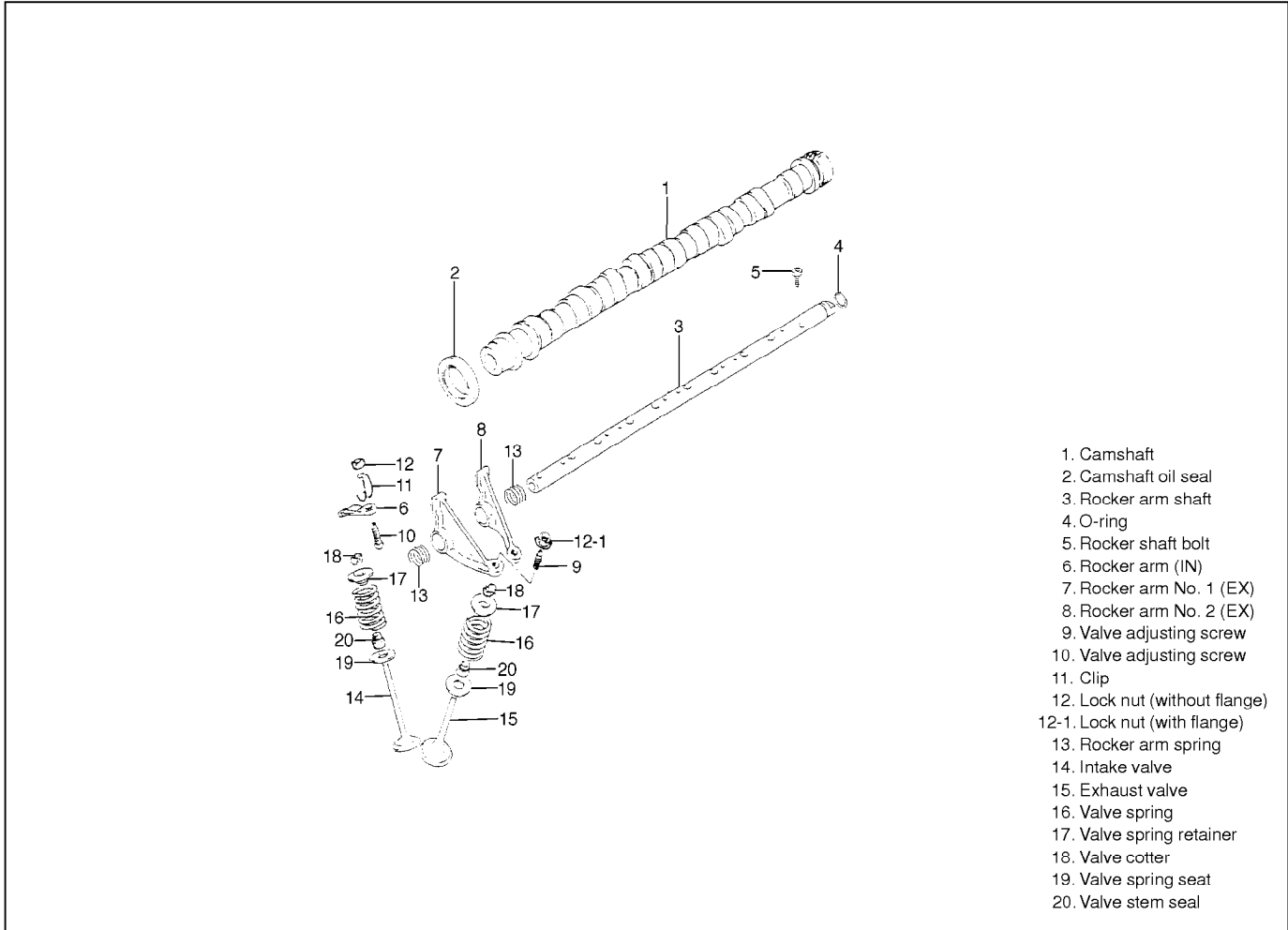

INSPECTION

Rocker Arm-to-Rocker Arm Shaft Clearance

Using a micrometer and a bore gauge, measure rocker shaft dia. and rocker arm I.D.

Difference between two readings is arm-to-shaft clearance on which a limit is specified.

If limit is exceeded, replace shaft or arm, or both.

Item	Standard	Limit
Rocker arm I.D.	15.996 – 16.014 mm (0.630 – 0.631 in.)	—
Rocker arm shaft dia.	15.969 – 15.984 mm (0.6287 – 0.6293 in.)	—
Arm-to-shaft clearance	0.012 – 0.045 mm (0.0001 – 0.0017 in.)	0.09 mm (0.0035 in.)

UNIT REPAIR OVERHAUL ENGINE ASSEMBLY

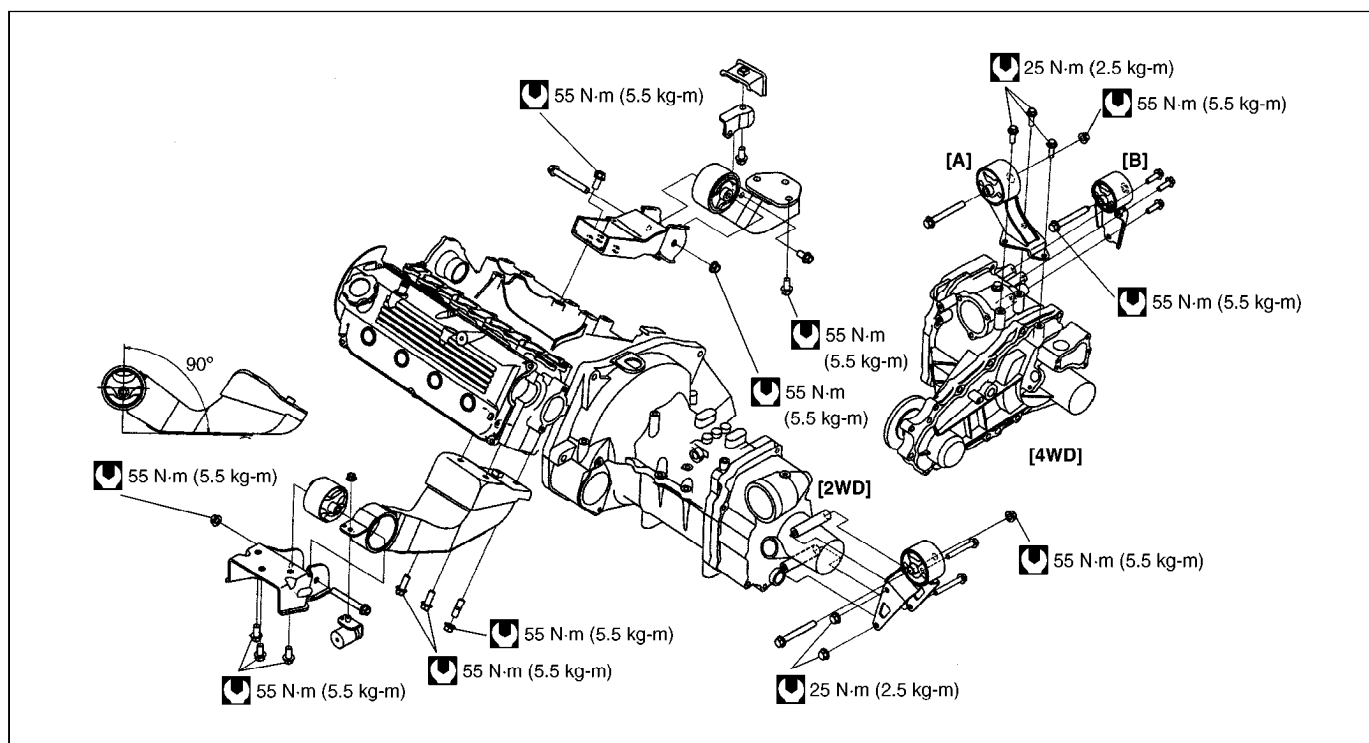

INSTALLATION

- 1) Combine engine with transmission.
- 2) Tighten engine mounting bracket bolts (R & L) and rear mounting nut as shown in the figure above.

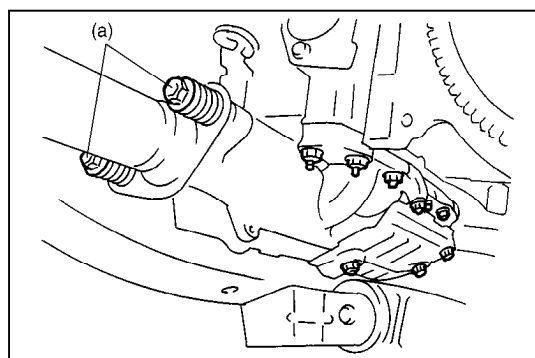

- 3) Reverse removal procedure for installation.
 - Install generator bracket, A/C compressor and generator referring to Section 1B and 6H.
 - Tighten bolts of exhaust pipes to specified torque.

Tightening Torque

(a): 50 N-m (5.0 kg-m, 36.5 lb-ft)

- 4) Adjust generator drive belt tension, referring to BELT TENSION INSPECTION in Section 6H.
- 5) Adjust A/C compressor belt tension, if equipped. Refer to Section 1B.
- 6) Connect gear shift cables to gear shift control lever, refer to GEAR SHIFT CONTROL INSTALLATION in Section 7A.
- 7) Connect parking brake cable to parking brake lever. Perform parking brake adjustment, refer to PARKING BRAKE INSPECTION AND ADJUSTMENT in Section 5.
- 8) Install front seat, refer to FRONT SEAT INSTALLATION in Section 9.
- 9) Adjust clutch pedal free travel, referring to Section 7C.
- 10) Adjust accelerator cable play. Refer to Section 6E.
- 11) Check to ensure that all removed parts are back in place. Reinstall any necessary parts which have not been reinstalled.
- 12) Refill engine with engine oil, referring to item ENGINE OIL CHANGE in Section 0B.
- 13) Refill cooling system and bleed air from system referring to Section 6B.
- 14) Verify that there is no fuel leakage, coolant leakage and exhaust gas leakage at each connection.

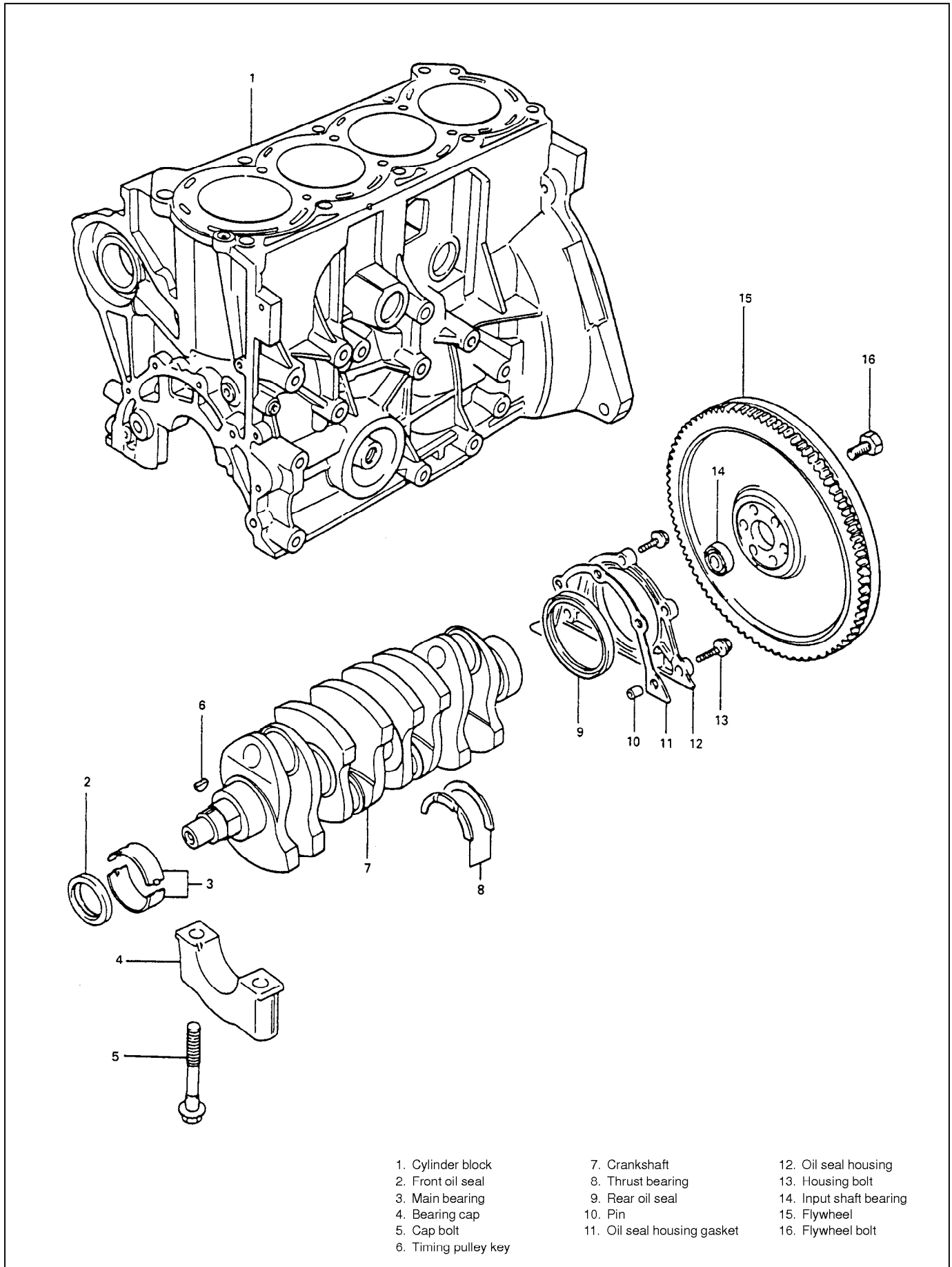
MAIN BEARINGS, CRANKSHAFT AND CYLINDER BLOCK

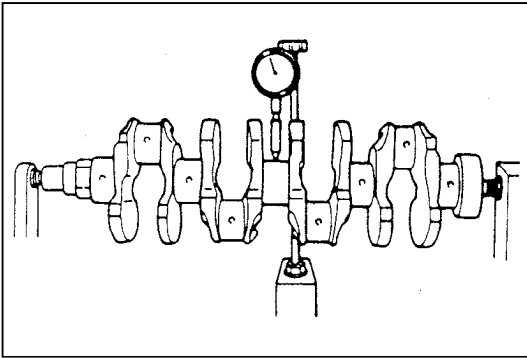

INSPECTION

Crankshaft

Crankshaft runout

Using a dial gauge, measure runout at center journal. Rotate crankshaft slowly. If runout exceeds its limit, replace crankshaft.

Limit on runout: 0.06 mm (0.0023 in.)

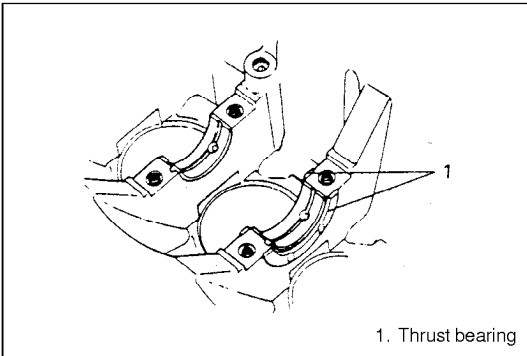

Crankshaft thrust play

Measure this play with crankshaft set in cylinder block in the normal manner, that is, with thrust bearing and journal bearing caps installed.

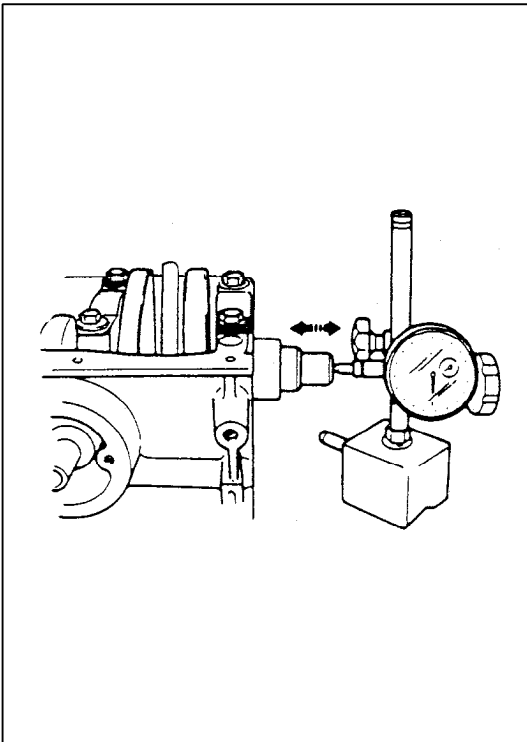

Use a dial gauge to read displacement in axial (thrust) direction of crankshaft.

If its limit is exceeded, replace thrust bearing with new standard one or oversize one to obtain standard thrust play.

Item	Standard	Limit
Crankshaft thrust play	0.11 – 0.31 mm (0.0044 – 0.0122 in.)	0.38 mm (0.0149 in.)

Item	Standard	Oversize:
Thickness of crankshaft thrust bearing	2.500 mm (0.0984 in.)	0.125 mm (0.0049 in.) 2.563 mm (0.1009 in.)

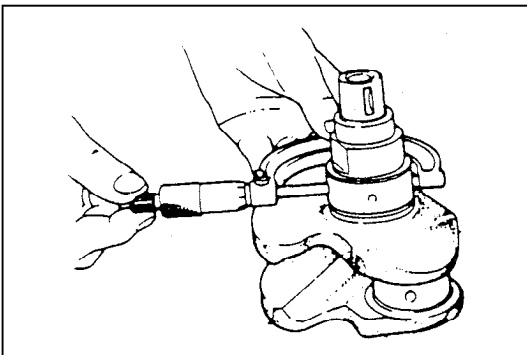

Out-of-round and taper (uneven wear) of journals

An unevenly worn crankshaft journal shows up as a difference in diameter at a cross section or along its length (or both). This difference, if any, is determined by taking micrometer readings.

If any one of journals is badly damaged or if amount of uneven wear in the sense explained above exceeds its limit, regrind or replace crankshaft.

Limit on out-of-round and taper: 0.01 mm (0.0004 in.)

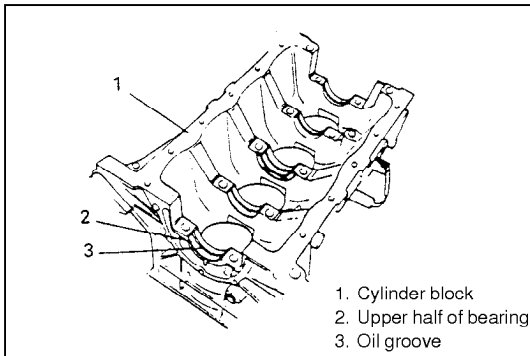

Main Bearings

General information

- Service main bearings are available in standard size and 0.25 mm (0.0098 in.) undersize, and each of them has 5 kinds of bearings differing in tolerance.
- Upper half of bearing has oil groove as shown in figure. Install this half with oil groove to cylinder block.

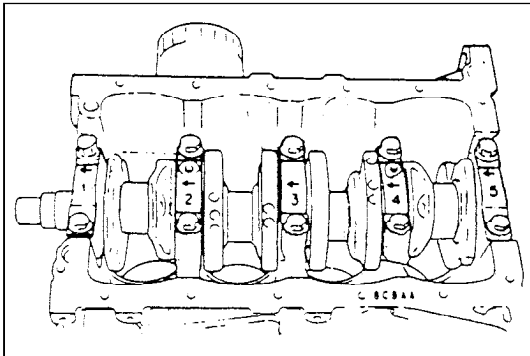

- On each main bearing cap, arrow mark and number are embossed as shown in figure.

When installing each bearing cap to cylinder block, point arrow mark toward crankshaft pulley side and install each cap from that side to flywheel side in ascending order of numbers "1", "2", "3", "4" and "5". Tighten cap bolts to specified torque.

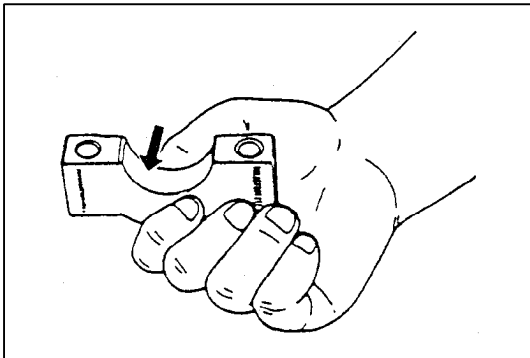

Inspection

Check bearings for pitting, scratches, wear or damage.

If any malcondition is found, replace both upper and lower halves. Never replace one half without replacing the other half.

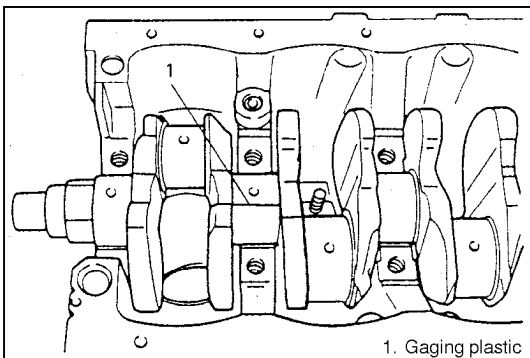

Main bearing clearance

Check clearance by using gaging plastic according to following procedure.

- 1) Remove bearing caps.
- 2) Clean bearings and main journals.
- 3) Place a piece of gaging plastic to full width of bearing (parallel to crankshaft) on journal, avoiding oil hole.

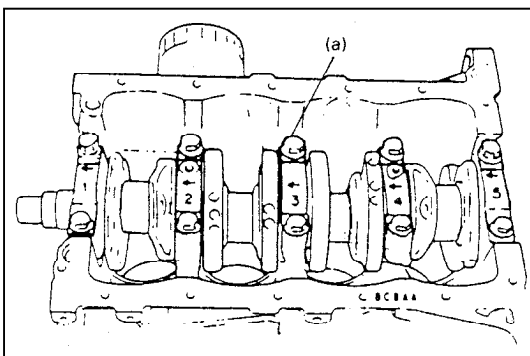

- 4) Install bearing cap as previously outlined and evenly torque cap bolts to specified torque.

Bearing cap **MUST** be torqued to specification in order to assure proper reading of clearance.

Tightening Torque

(a): 54 N·m (5.4 kg·m, 39.0 lb-ft)

NOTE:

Do not rotate crankshaft while gaging plastic is installed.

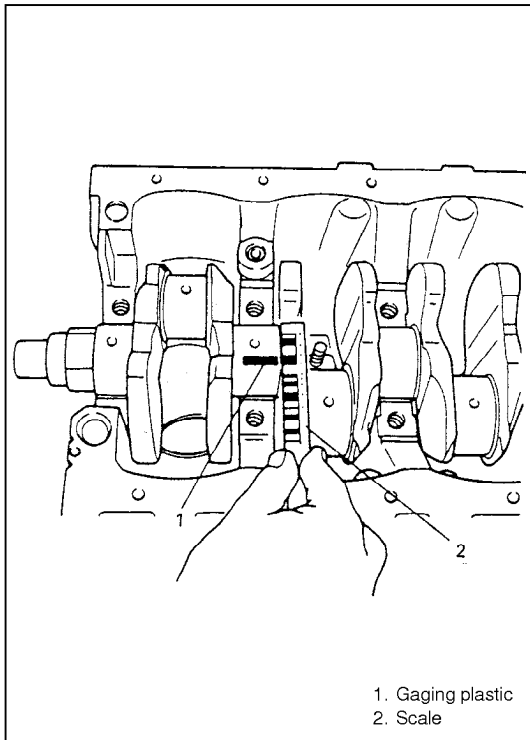

1. Gaging plastic
2. Scale

5) Remove cap and using scale on gaging plastic envelope, measure gaging plastic width at its widest point. If clearance exceeds its limit, replace bearing. Always replace both upper and lower inserts as a unit.

A new standard bearing may produce proper clearance. If not, it will be necessary to regrind crankshaft journal for use of 0.25 mm undersize bearing.

After selecting new bearing, recheck clearance.

	Standard	Limit
Bearing clearance	0.013 – 0.033 mm (0.0005 – 0.0013 in.)	0.060 mm (0.0023 in.)

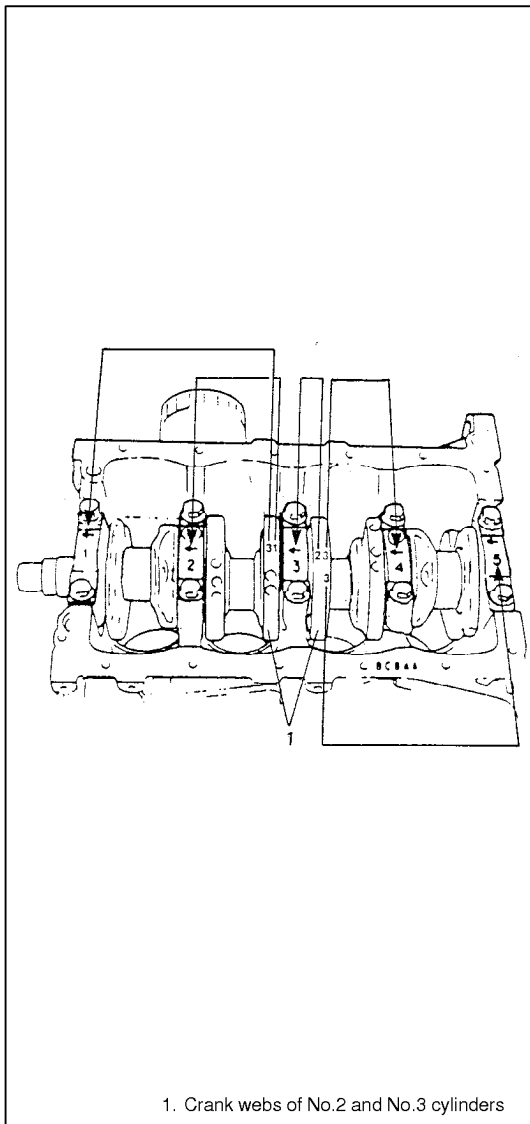

1. Crank webs of No.2 and No.3 cylinders

Selection of main bearings

STANDARD BEARING:

If bearing is in malcondition, or bearing clearance is out of specification, select a new standard bearing according to following procedure and install it.

1) First check journal diameter by using following procedure.

As shown in figure, crank webs of No.2 and No.3 cylinders have five stamped numerals.

Three kinds of numerals (“1”, “2” and “3”) represent following journal diameters.

Numeral stamped	Journal diameter
1	44.994 – 45.000 mm (1.7714 – 1.7716 in.)
2	44.988 – 44.994 mm (1.7712 – 1.7714 in.)
3	44.982 – 44.988 mm (1.7709 – 1.7712 in.)

The first, second, third, fourth and fifth (left to right) stamped numerals represent journal diameters at bearing caps “1”, “2”, “3”, “4” and “5” respectively.

For example, in figure, the first (leftmost) numeral “3” indicates that journal dia. at bearing cap “1” is within 44.982 – 44.988 mm, and second one “1” indicate that journal dia. at cap “2” is within 44.994 – 45.000 mm.

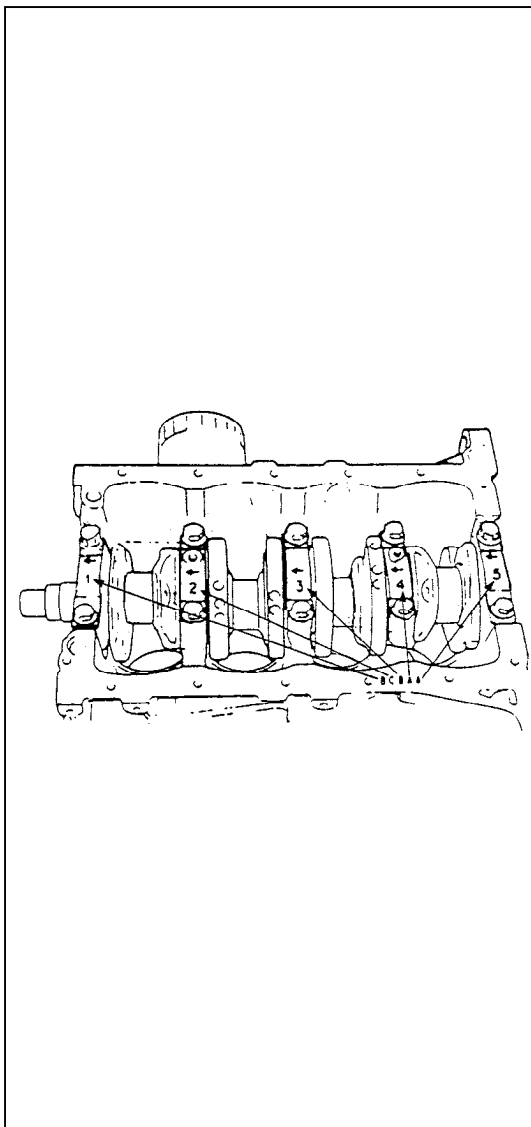

2) Next, check bearing cap bore diameter without bearing. On mating surface of cylinder block, four alphabets are stamped as shown in figure.

Three kinds of alphabets (“A”, “B” and “C”) represent following cap bore diameters.

Alphabet stamped	Bearing cap bore diameter (without bearing)
A	49.000 – 49.006 mm (1.9291 – 1.9294 in.)
B	49.006 – 49.012 mm (1.9294 – 1.9296 in.)
C	49.012 – 49.018 mm (1.9296 – 1.9298 in.)

The first, second, third, fourth and fifth (left to right) stamped alphabets represent cap bore diameters of bearing caps “1”, “2”, “3”, “4” and “5”, respectively.

For example, in figure, the first (leftmost) alphabet “B” indicates that cap bore dia. of bearing cap “1” is within 49.006 – 49.012 mm, and the fifth (rightmost) alphabet “A” indicates that cap bore dia. of cap “5” is within 49.000 – 49.006 mm.

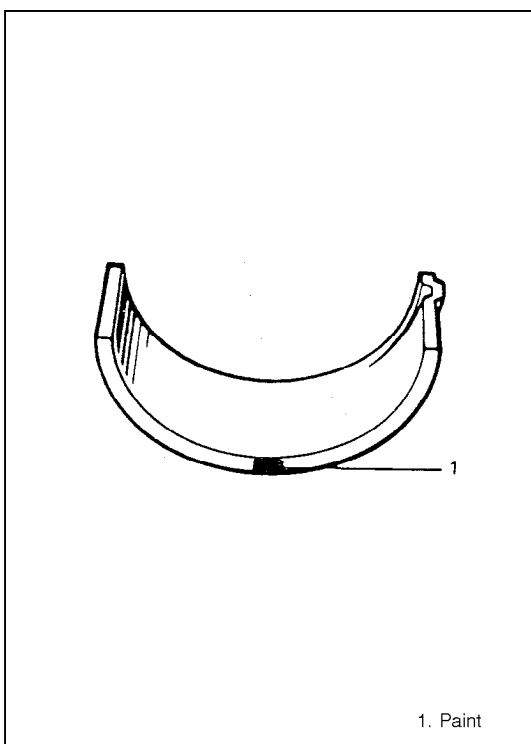

3) There are five kinds of standard bearings differing in thickness. To distinguish them, they are painted in following colors at the position as indicated in figure.

Each color indicates following thickness at the center of bearing.

Color painted	Bearing thickness
Green	1.996 – 2.000 mm (0.0786 – 0.0788 in.)
Black	1.999 – 2.003 mm (0.0787 – 0.0789 in.)
Colorless (no paint)	2.002 – 2.006 mm (0.0788 – 0.0790 in.)
Yellow	2.005 – 2.009 mm (0.0789 – 0.0791 in.)
Blue	2.008 – 2.012 mm (0.0790 – 0.0792 in.)

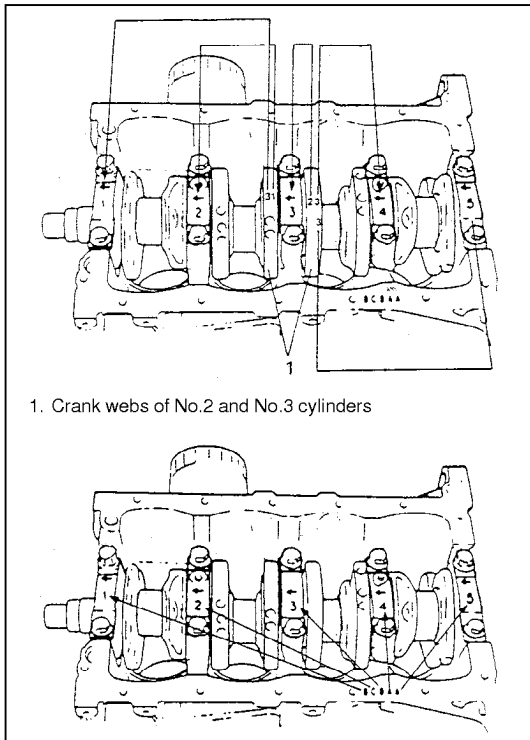

4) From numerals stamped on crank webs of No.2 and No.3 cylinders and the alphabets stamped on mating surface of cylinder block, determine new standard bearing to be installed to journal, by referring to table given below.

For example, if numeral stamped on crank web is "1" and alphabet stamped on mating surface is "B", install a new standard bearing painted in "Black" to its journal.

		Numeral stamped on crank web (Journal diameter)		
		1	2	3
Alphabet stamped on mating surface (Bearing cap bore dia.)	A	Green	Black	Colorless
	B	Black	Colorless	Yellow
	C	Colorless	Yellow	Blue
New standard bearing to be installed.				

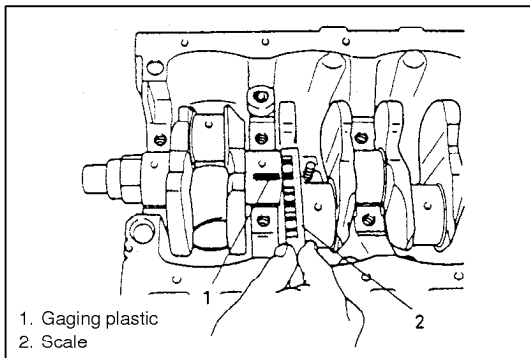

5) Using gaging plastic, check bearing clearance with newly selected standard bearing.

If clearance still exceeds its limit, use next thicker bearing and recheck clearance.

6) When replacing crankshaft or cylinder block due to any reason, select new standard bearings to be installed by referring to numerals stamped on new crankshaft or alphabets stamped on mating surface of new cylinder block.

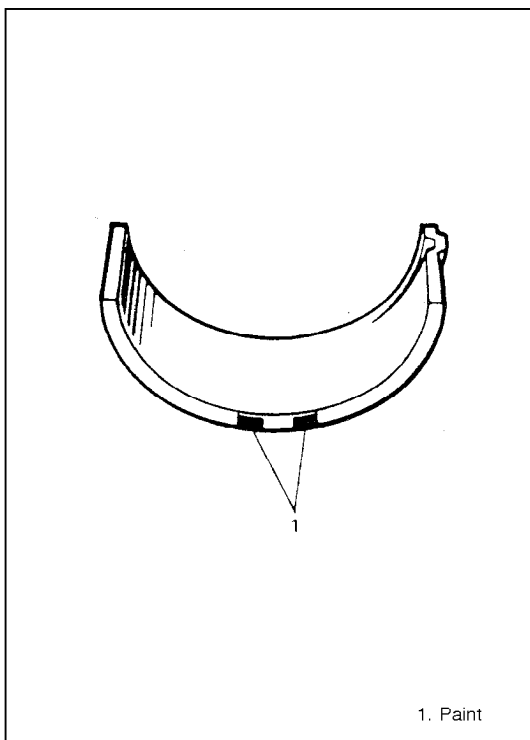

UNDERSIZE BEARING (0.25 mm):

- 0.25 mm undersize bearing is available, in five kinds varying in thickness.

To distinguish them, each bearing is painted in following colors at such position as indicated in figure.

Each color represents following thickness at the center of bearing.

Color painted	Bearing thickness
Green & Red	2.121 – 2.125 mm (0.0836 – 0.0838 in.)
Black & Red	2.124 – 2.138 mm (0.0836 – 0.0838 in.)
Red only	2.127 – 2.131 mm (0.0837 – 0.0839 in.)
Yellow & Red	2.130 – 2.134 mm (0.0839 – 0.0840 in.)
Blue & Red	2.133 – 2.137 mm (0.0840 – 0.0841 in.)

- If necessary, regrind crankshaft journal and select under-size bearing to use with it as follows.

1) Regrind journal to following finished diameter.

**Finished diameter: 44.732 – 44.750 mm
(1.7611 – 1.7618 in.)**

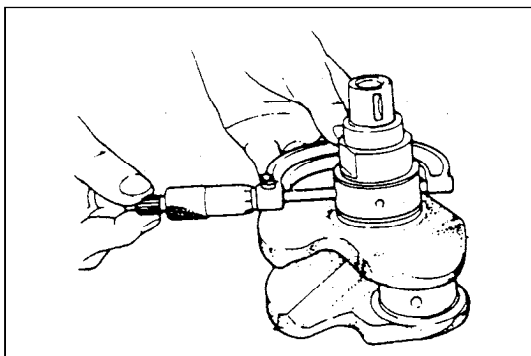

- 2) Using micrometer, measure reground journal diameter. Measurement should be taken in two directions perpendicular to each other in order to check for out-of-round.
- 3) Using journal diameter measured above and alphabets stamped on mating surface of cylinder block, select an undersize bearing by referring to table given below. Check bearing clearance with newly selected undersize bearing.

		Measured journal diameter		
		44.744 – 44.750 mm (1.7616 – 1.7618 in.)	44.738 – 44.744 mm (1.7613 – 1.7616 in.)	44.732 – 44.738 mm (1.7611 – 1.7613 in.)
Alphabet stamped on mating surface of cylinder block	A	Green & Red	Black & Red	Red only
	B	Black & Red	Red only	Yellow & Red
	C	Red only	Yellow & Red	Blue & Red
		Undersize bearing to be installed		

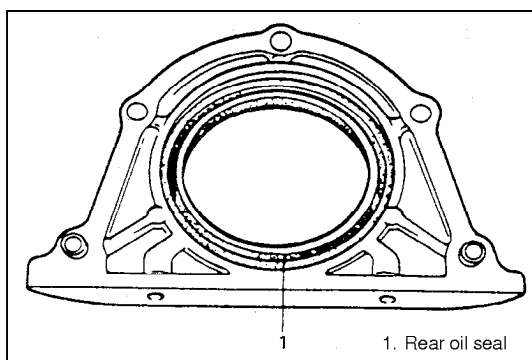

Rear Oil Seal

Carefully inspect oil seal for wear or damage. If its lip is worn or damaged, replace it.

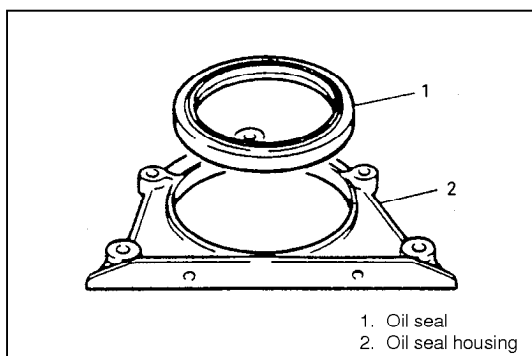

For oil seal installation, press-fit rear oil seal so that oil seal housing end face is flush with oil seal end face.

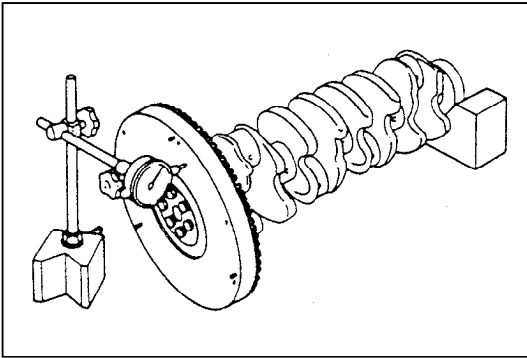

Flywheel

- If ring gear is damaged, cracked or worn, replace flywheel.
- If the surface contacting clutch disc is damaged, or excessively worn, replace flywheel.
- Check flywheel for face runout with dial gauge. If runout exceeds its limit, replace flywheel.

Limit on runout: 0.2 mm (0.0078 in.)

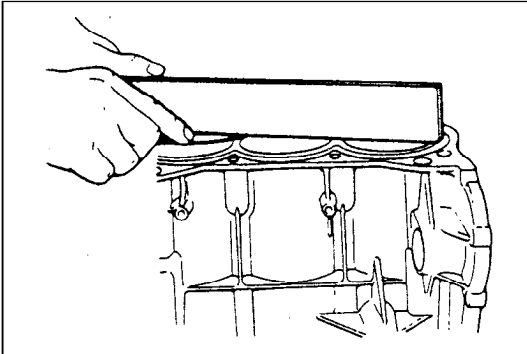

Cylinder Block

Distortion of gasketed surface

Using straightedge and thickness gauge, check gasketed surface for distortion and, if flatness exceeds its limit, correct it.

Item	Standard	Limit
Flatness	0.03 mm (0.0012 in.)	0.06 mm (0.0024 in.)

Honing or reboring cylinders

- 1) When any cylinder needs reboring, all other cylinders must also be rebored at the same time.
- 2) Select oversized piston according to amount of cylinder wear.

Size	Piston diameter
O/S 0.25	74.220 – 74.230 mm (2.9220 – 2.9224 in.)
O/S 0.50	74.470 – 74.480 mm (2.9319 – 2.9323 in.)

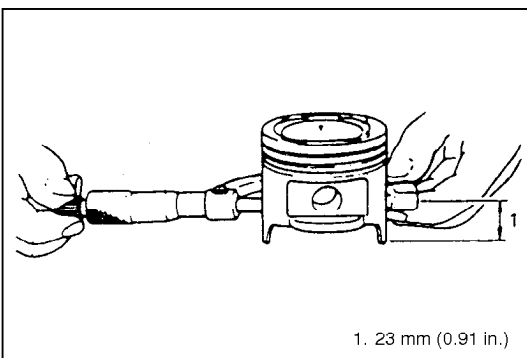

1. 23 mm (0.91 in.)

- 3) Using micrometer, measure piston diameter.

- 4) Calculate cylinder bore diameter to be rebored.

$$D = A + B - C$$

D: Cylinder bore diameter to be rebored.

A: Piston diameter as measured.

B: Piston clearance = 0.02 – 0.04 mm
(0.0008 – 0.0015 in.)

C: Allowance for honing = 0.02 mm (0.0008 in.)

- 5) Rebore and hone cylinder to calculated dimension.

NOTE:

Before reboring, install all main bearing caps in place and tighten to specification to avoid distortion of bearing bores.

- 6) Measure piston clearance after honing.

SECTION 6B

ENGINE COOLING

NOTE:

For the descriptions (items) not found in this section, refer to the same section of the Service Manual mentioned in the FOREWORD of this manual.

MAINTENANCE

COOLING SYSTEM SERVICE

WARNING:

To help avoid danger of being burned, do not remove radiator cap while engine and radiator are still hot. Scalding fluid and steam can be blown out under pressure if cap is taken off too soon.

Cooling system should be serviced as follows.

- 1) Check cooling system for leakage or damage.
- 2) Wash radiator cap and filler neck with clean water by removing radiator cap when engine is cold.
- 3) Check coolant for proper level and freeze protection.

6B

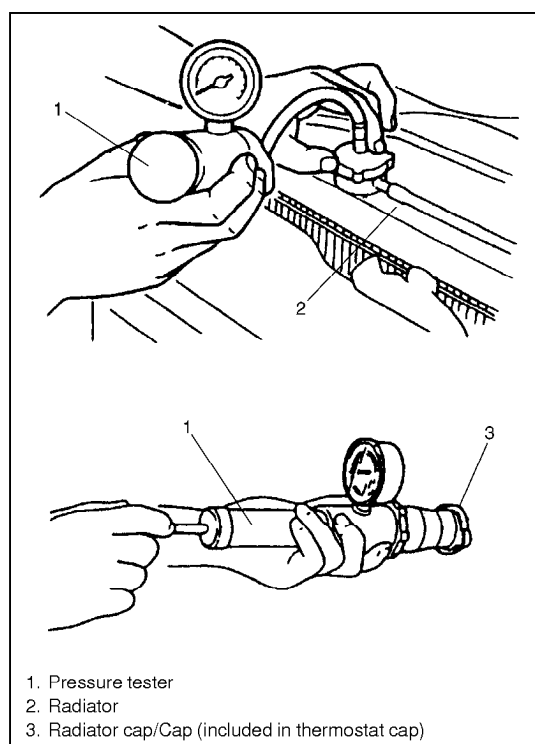

- 4) Using a pressure tester, check system, radiator cap for proper pressure holding capacity 110 kPa (1.1 kg/cm², 15.6 psi). If replacement of cap is required, use proper cap specified for this vehicle.

NOTE:

After installing radiator cap to radiator, make sure that the ear of cap lines is parallel to radiator.

- 5) Tighten hose clamps and inspect all hoses. Replace hoses whenever cracked, swollen or otherwise deteriorated.
- 6) Clean frontal area of radiator core.
- 7) Using a pressure tester, check cap of thermostat cap for proper pressure holding capacity 110 kPa (1.1 kg/cm², 15.6 psi). If replacement of cap is required, use proper cap specified for this vehicle.

CAUTION:

When removing cap of thermostat cap, drain coolant from system in advance.

SECTION 6E

ENGINE AND EMISSION CONTROL SYSTEM

WARNING:

For vehicles equipped with Supplemental Restraint (Air Bag) System:

- Service on and around the air bag system components or wiring must be performed only by an authorized SUZUKI dealer. Refer to “Air Bag System Components and Wiring Location View” under “General Description” in air bag system section in order to confirm whether you are performing service on or near the air bag system components or wiring. Please observe all WARNINGS and “Service Precautions” under “On-Vehicle Service” in air bag system section before performing service on or around the air bag system components or wiring. Failure to follow WARNINGS could result in unintentional activation of the system or could render the system inoperative. Either of these two conditions may result in severe injury.
- Technical service work must be started at least 90 seconds after the ignition switch is turned to the “LOCK” position and the negative cable is disconnected from the battery. Otherwise, the system may be activated by reserve energy in the Sensing and Diagnostic Module (SDM).

NOTE:

- This section covers vehicle equipped with HO2S-2 (rear heated oxygen sensor) or immobilizer system. For other than the vehicle, refer to the same section of the Service Manual mentioned in FOREWORD of this manual.
- Whether following systems (parts) are used in the particular vehicle or not depends on specifications. Be sure to bear this in mind when performing service work.
 - EGR valve
 - Heated oxygen sensor (s) or CO adjusting resistor
 - Three way catalytic converter (TWC) and warm up three-way catalytic converter (WU-TWC)

6E

CONTENTS

GENERAL DESCRIPTION	6E- 2	Idle Air Control Valve	6E-18
AIR INTAKE SYSTEM	6E- 6	FUEL DELIVERY SYSTEM	6E-19
FUEL DELIVERY SYSTEM	6E- 7	Fuel Pressure Inspection	6E-19
ELECTRONIC CONTROL SYSTEM	6E- 8	Fuel Pump	6E-20
Engine and Emission Control		Fuel Pressure Regulator	6E-21
Input/Output Table	6E- 9	Fuel Injector	6E-22
DIAGNOSIS	See Section 6.	ELECTRONIC CONTROL SYSTEM	6E-26
ON-VEHICLE SERVICE	6E-12	ECM	6E-26
Accelerator Cable Adjustment	6E-12	MAP Sensor	6E-26
Idle Speed/Idle Air Control (IAC)		TP Sensor	6E-27
Duty Inspection	6E-12	IAT Sensor	6E-28
Idle mixture Inspection/Adjustment	6E-14	ECT Sensor	6E-29
AIR INTAKE SYSTEM	6E-15	Heated Oxygen Sensor -1 and -2	6E-30
Throttle Body	6E-15	Camshaft Position Sensor	6E-31
		Crankshaft Position Sensor	6E-32

Vehicle Speed Sensor	6E-32	EGR System	6E-36
Main Relay, Fuel Pump Relay and Radiator Fan Control Relay	6E-33	EVAP Control System	6E-38
Fuel Cut Operation	6E-33	PCV System	6E-39
Fuel Level Sensor (gauge)	6E-33	SPECIAL TOOLS	6E-40
Radiator Fan Control System	6E-34	TIGHTENING TORQUE	
Fuel Pressure Control Valve	6E-35	SPECIFICATIONS	6E-40
EMISSION CONTROL SYSTEM	6E-36		

GENERAL DESCRIPTION

The engine and emission control system is divided into 4 major sub-systems: air intake system, fuel delivery system, electronic control system and emission control system.

Air intake system includes air cleaner, throttle body, IAC valve and intake manifold.

Fuel delivery system includes fuel pump, delivery pipe, fuel pressure regulator, etc. Electronic control system includes ECM, various sensors and controlled devices.

Emission control system includes EGR, EVAP and PCV system.

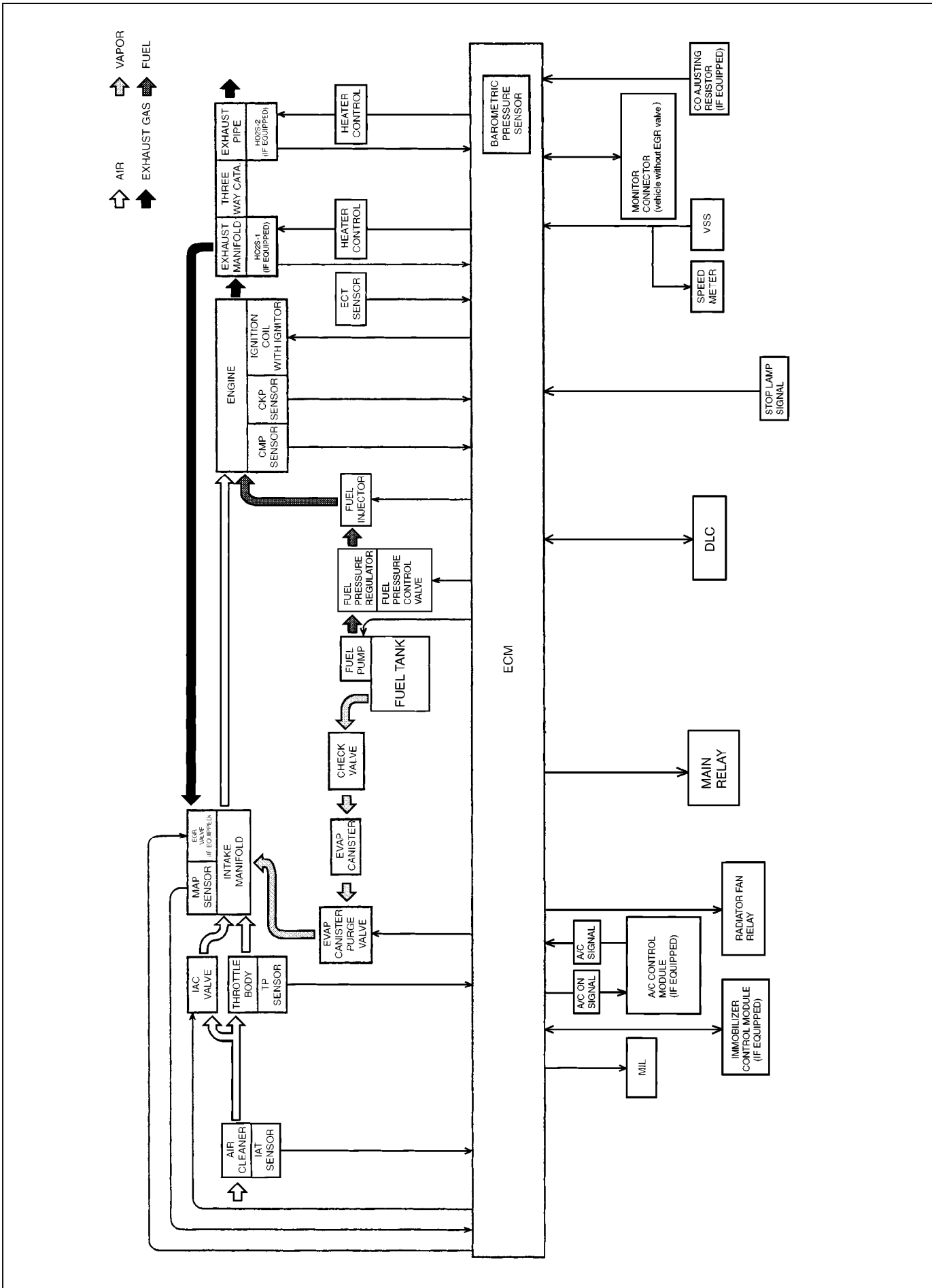

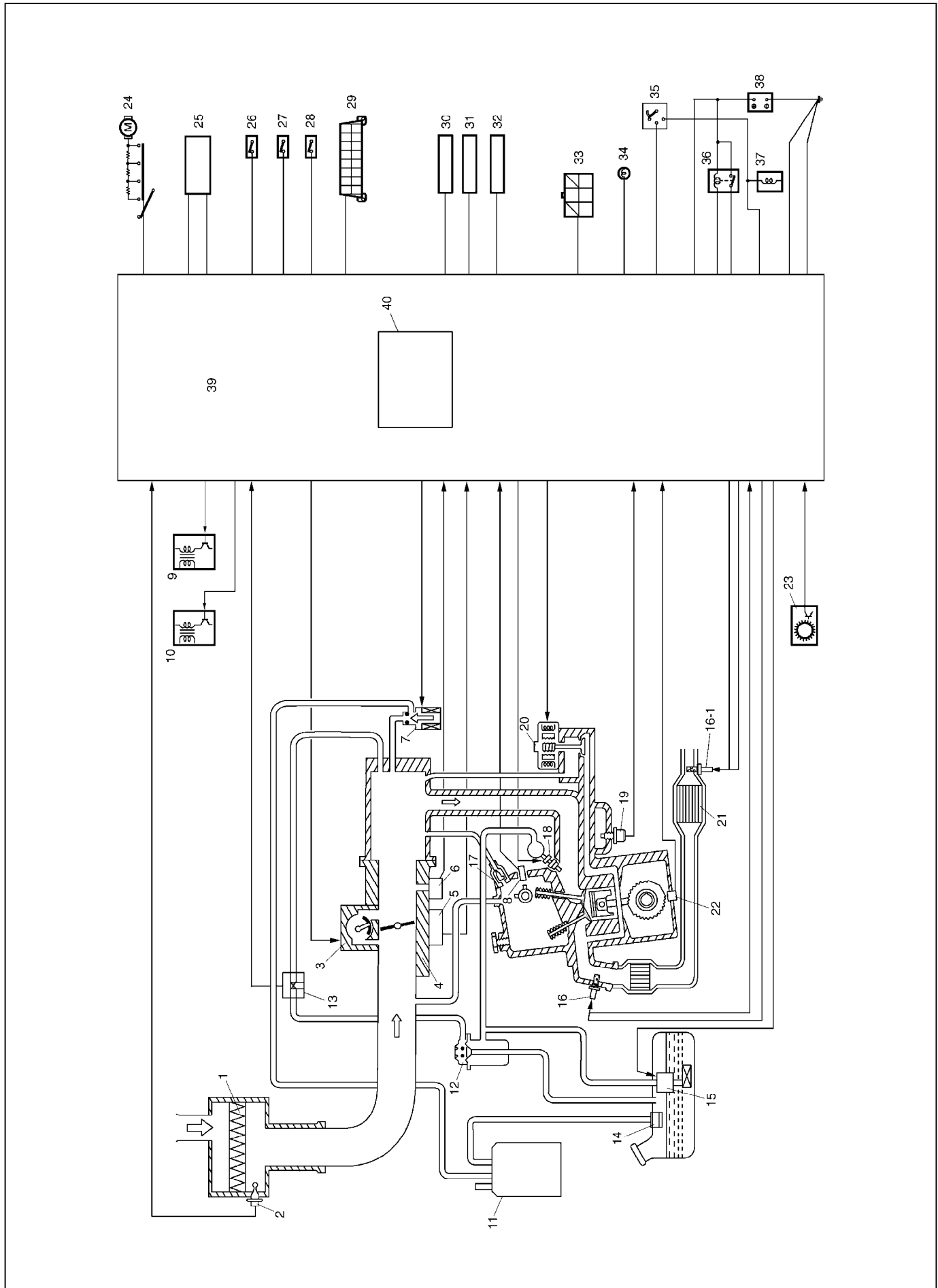

- | | | |
|---|---|---|
| 1. Air Cleaner | | |
| 2. IAT sensor | | |
| 3. IAC valve | | |
| 4. Throttle body | | |
| 5. TP sensor | | |
| 6. MAP sensor | | |
| 7. EVAP canister purge valve | | |
| 8. CMP sensor | | |
| 9. Ignition coil assembly for No.1 and No.4 spark plug | | |
| 10. Ignition coil assembly for No.2 and No.3 spark plug | | |
| 11. EVAP canister | | |
| 12. Fuel pressure regulator | | |
| 13. Fuel pressure control valve | | |
| 14. Tank pressure control valve | | |
| 15. Fuel pump | | |
| | 16. Heated Oxygen Sensor (HO2S)-1 (if equipped) | 28. Rear defogger switch |
| | 16-1. Heated Oxygen Sensor (HO2S)-2 (if equipped) | 29. DLC |
| | 17. PCV valve | 30. Ignition timing adjusting resistor (if equipped) |
| | 18. Fuel injector | 31. CO adjusting resistor (if equipped) |
| | 19. ECT sensor | 32. Radiator fan relay |
| | 20. EGR valve (if equipped) | 33. Monitor connector (vehicle without EGR valve) |
| | 21. Three way catalytic convertor (if equipped) | 34. Malfunction indicator lamp |
| | 22. CKP sensor | 35. Ignition switch |
| | 23. VSS | 36. Main relay |
| | 24. Heater blower fan switch | 37. Starter magnetic switch |
| | 25. A/C control module (if equipped) | 38. Battery |
| | 26. Lighting switch | 39. ECM |
| | 27. Stop lamp switch | 40. Barometric pressure sensor (vehicle with EGR valve) |

AIR INTAKE SYSTEM

The main components of the air intake system are air cleaner (1), air cleaner outlet hose (2), throttle body (3), idle air control valve (4) and intake manifold (5). The air (by the amount corresponding to the throttle valve (6) opening and engine speed) is filtered by the air cleaner (1), passes through the throttle body (3), is

distributed by the intake manifold (5) and finally drawn into each combustion chamber.

When the idle air control valve (4) is opened according to the signal from ECM, the air (7) bypasses the throttle valve (6) through bypass passage and is finally drawn into the intake manifold (5).

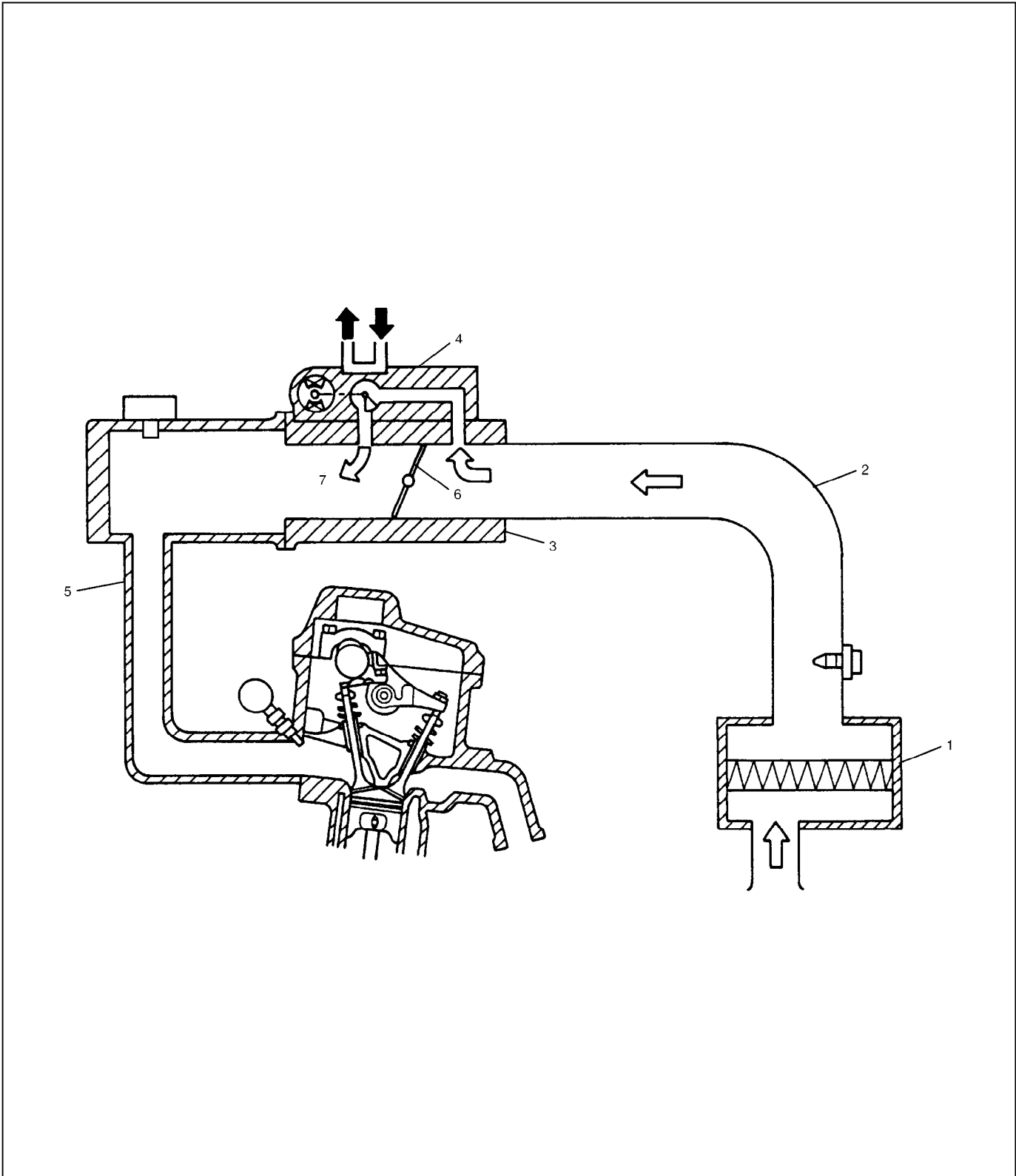

FUEL DELIVERY SYSTEM

The fuel delivery system consists of the fuel tank (1), fuel pump (2), fuel filter (3), fuel pressure regulator (11), delivery pipe (9) and fuel injectors (10).

The fuel in the fuel tank is pumped up by the fuel pump, filtered by the fuel filter and fed under pressure to each injector through the delivery pipe.

As the fuel pressure applied to the injector (the fuel

pressure in the fuel feed line) is always kept a certain amount higher than the pressure in the intake manifold by the fuel pressure regulator, the fuel is injected into the intake port of the cylinder head when the injector open according to the injection signal from ECM.

The fuel relieved by the fuel pressure regulator returns through the fuel return line (8) to the fuel tank.

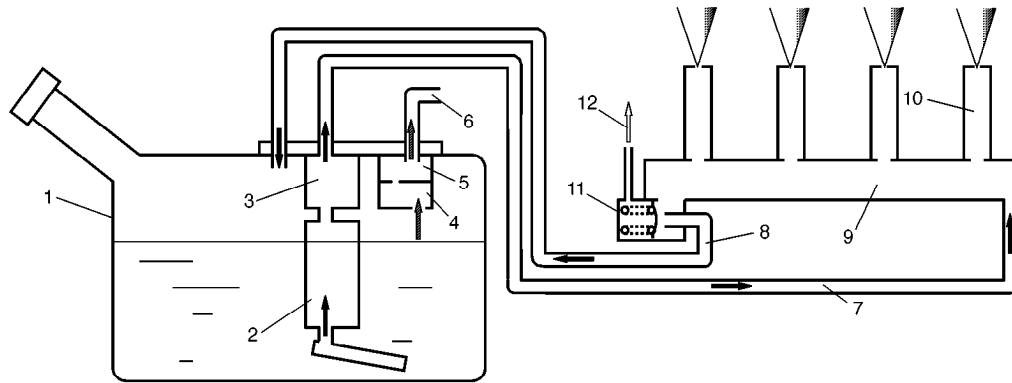

- | | |
|-------------------------------------|------------------------------------|
| 1. Fuel tank | 7. Fuel feed line |
| 2. Fuel pump | 8. Fuel return line |
| 3. Fuel filter | 9. Fuel delivery pipe |
| 4. Fuel cut valve | 10. Fuel injector |
| 5. Fuel tank pressure control valve | 11. Fuel pressure regulator |
| 6. To EVAP canister | 12. To fuel pressure control valve |

ELECTRONIC CONTROL SYSTEM

The electronic control system consists of 1) various sensors which detect the state of engine and driving conditions, 2) ECM which controls various devices according to the signals from the sensors and 3) various controlled devices.

Functionally, it is divided into the following sub systems:

- Fuel injection control system

- Idle speed control system
- Fuel pump control system
- A/C control system (if equipped)
- Radiator fan control system
- EGR system (if equipped)
- Evaporative emission control system
- Oxygen sensor heater control system
- Ignition control system

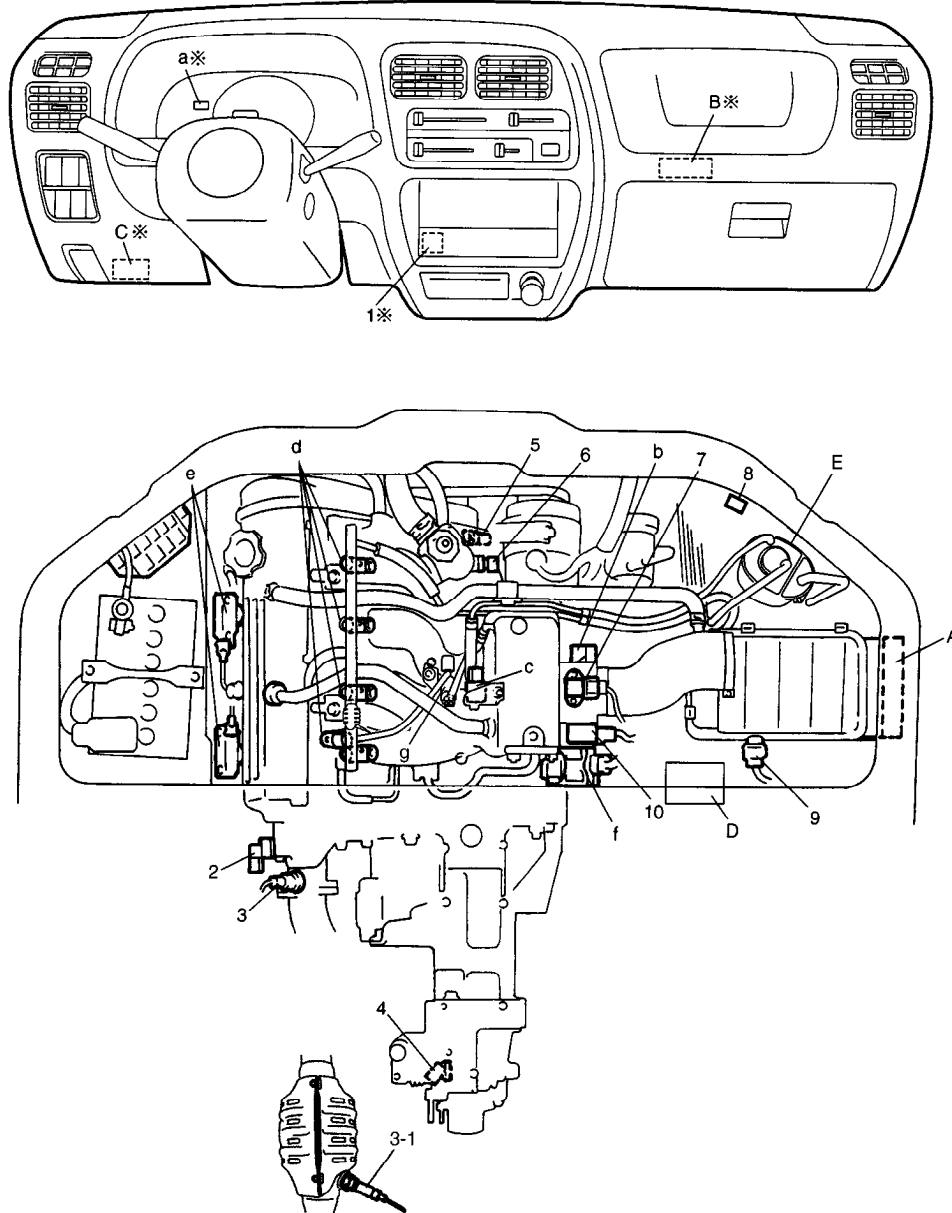

- 1. CO adjusting resistor (if equipped)
- 2. CMP sensor
- 3. HO2S-1 (if equipped)
- 3-1. HO2S-2 (if equipped)
- 4. VSS
- 5. CKP sensor
- 6. ECT sensor
- 7. MAP sensor
- 8. Connector for ignition timing adjusting resistor (if equipped)
- 9. IAT sensor
- 10. TP sensor

- a: MIL
- b: IAC valve
- c: EVAP canister purge valve
- d: Fuel injector
- e: Ignitor coil
- f: EGR valve (if equipped)
- g: Fuel pressure control valve

- A: ECM
- B: A/C control module (if equipped)
- C: DLC
- D: ABS hydraulic unit (if equipped)
- E: EVAP canister

NOTE:

Above figure shows left-hand steering vehicle. For right-hand steering vehicle, parts with (*) are installed at the other side.

ENGINE & EMISSION CONTROL INPUT/OUTPUT TABLE

INPUT \ OUTPUT		ELECTRIC CONTROL DEVICE											
		FUEL PUMP RELAY	FUEL INJECTOR	HO2S HEATER	IAC VALVE	IGNITION COIL WITH IGNITER	EGR VALVE (IF EQUIPPED)	EVAP CANISTER PURGE VALVE	A/C CONTROL MODULE (IF EQUIPPED)	RADIATOR FAN RELAY	MIL	MAIN RELAY	FUEL PRESSURE CONTROL VALVE
SIGNAL FROM SENSOR, SWITCH AND CONTROL MODULE	DIAGNOSIS SWITCH TERMINAL (VEHICLE WITHOUT EGR VALVE)										○		
	BAROMETRIC PRESSURE SENSOR (VEHICLE WITH EGR VALVE)		○		○						○		
	STOP LAMP SWITCH				○								
	STARTER SWITCH	○	○		○						○		
	IGNITION SWITCH	○	○	○	○	○	○	○		○		○	
	LIGHTING SWITCH				○								
	REAR DEFOGGER SWITCH (IF EQUIPPED)				○								
	BLOWER SWITCH				○								
	VSS				○					○	○		
	HEATED OXYGEN SENSOR-1 (IF EQUIPPED)		○					○			○		
	HEATED OXYGEN SENSOR-2 (IF EQUIPPED)	For detecting deterioration of three way catalytic convertor									○		
	IAT SENSOR		○		○	○	○	○			○		○
	ECT SENSOR		○	○	○	○	○	○	○	○	○		○
	TP SENSOR		○		○	○			○		○		
	MAP SENSOR		○	○	○	○	○	○			○		
	CMP SENSOR	○	○	○	○	○	○	○			○		
	CKP SENSOR	○	○	○	○	○	○	○	○		○		
	TEST SWITCH TERMINAL (VEHICLE WITHOUT EGR VALVE)					○							
A/C CONTROL MODULE (IF EQUIPPED)				○				○	○				

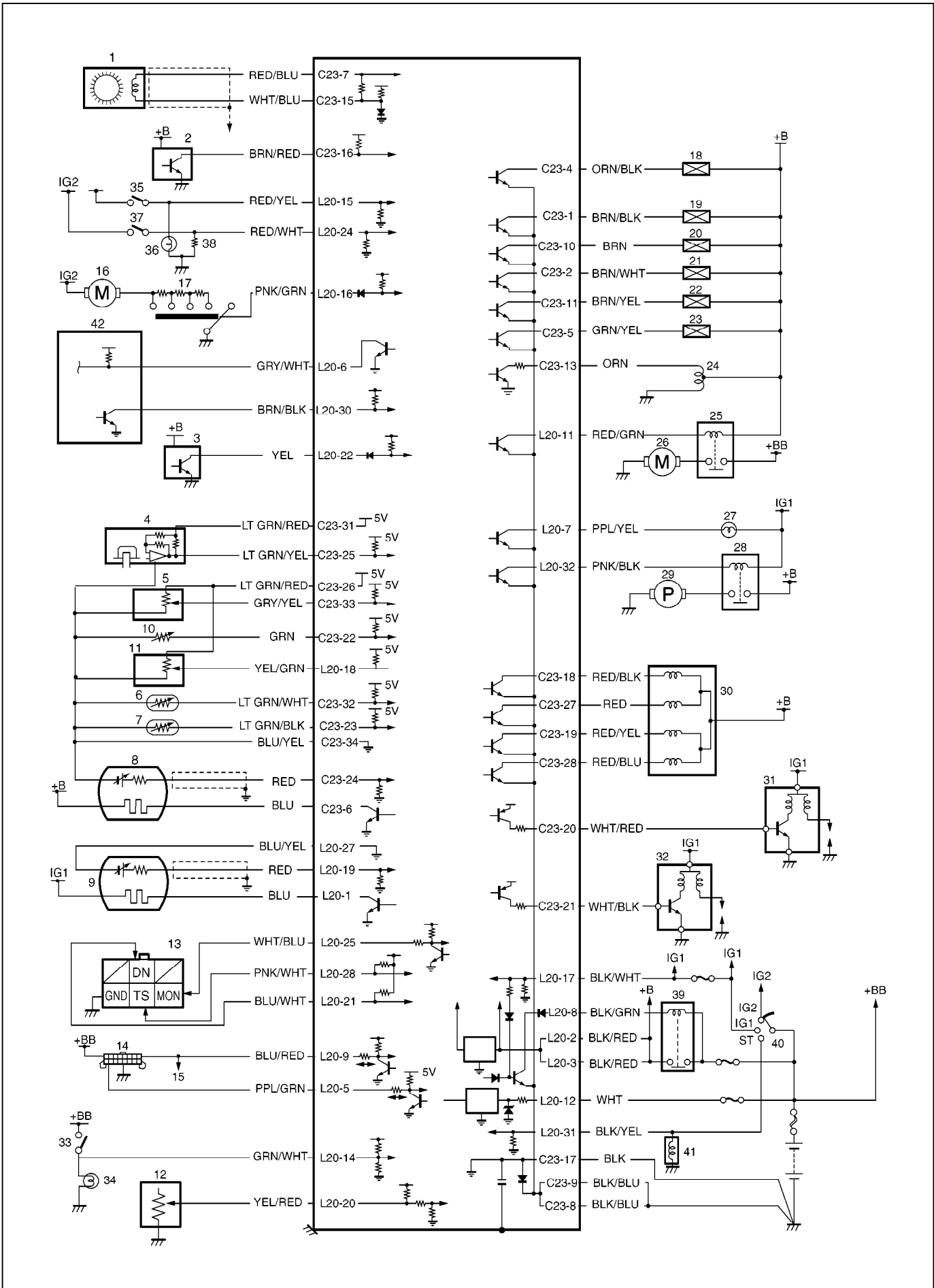

CON-NECTOR	TERMINAL	WIRE COLOR	CIRCUIT	CON-NECTOR	TERMINAL	WIRE COLOR	CIRCUIT
C23	1	BRN/BLK	No.1 fuel injector	L20	1	BLU	Heater of HO2S-2 (if equipped)
	2	BRN/WHT	No.3 fuel injector		2	BLK/RED	Power source
	3	-	-		3	BLK/RED	Power source
	4	ORN/BLK	Fuel pressure control valve		4	-	-
	5	GRN/YEL	EVAP canister purge valve		5	PPL/GRN	Data link connector
	6	BLU	Heater of HO2S-1 (if equipped)		6	GRY/WHT	A/C signal (if equipped)
	7	RED/BLU	CKP sensor		7	PPL/YEL	Malfunction indicator lamp
	8	BLK/BLU	Ground		8	BLK/GRN	Main relay
	9	BLK/BLU	Ground		9	BLU/RED	Data link connector
	10	BRN	No.2 fuel injector		10	-	-
	11	BRN/YEL	No.4 fuel injector		11	RED/GRN	Radiator fan relay
	12	-	-		12	WHT	Backup power source
	13	ORN	IAC valve		13	-	-
	14	-	-		14	GRN/WHT	Stop lamp switch
	15	WHT/BLU	CKP sensor		15	RED/YEL	Lighting switch
	16	BRN/RED	CMP sensor		16	PNK/GRN	Heater blower switch
	17	BLK	Ground for ECM		17	BLK/WHT	Ignition switch
	18	RED/BLK	EGR valve 1 (if equipped)		18	YEL/GRN	CO adjusting resistor (if equipped)
	19	RED/YEL	EGR valve 3 (if equipped)		19	RED	Heater of HO2S-2 (if equipped)
	20	WHT/RED	IG coil assembly for No.2 and No.3 spark plugs		20	YEL/RED	Fuel level gauge
	21	WHT/BLK	IG coil assembly for No.1 and No.4 spark plugs		21	BLU/WHT	Diagnosis switch terminal (vehicle without EGR valve)
	22	YEL/GRN	Ignition timing adjusting resistor (if equipped)		22	YEL	VSS
	23	LT GRN/BLK	IAT sensor		23	-	-
	24	RED	HO2S-1 (if equipped)		24	RED/WHT	Rear defogger switch (if equipped)
	25	LT GRN/YEL	MAP sensor		25	WHT/BLU	Duty output terminal (vehicle without EGR valve)
	26	LT GRN/RED	Power supply for sensor		26	-	-
	27	RED	EGR valve 2 (if equipped)		27	BLU/YEL	Ground for sensor
	28	RED/BLU	EGR valve 4 (if equipped)		28	PNK/WHT	Test switch terminal (vehicle without EGR valve)
	29	-	-		29	-	-
	30	-	-		30	BRN/BLK	A/C ON signal (if equipped)
	31	LT GRN/RED	Power supply for sensor		31	BLK/YEL	Engine start signal
	32	LT GRN/WHT	ECT sensor		32	PNK/BLK	Fuel pump relay
	33	GRY/YEL	TP sensor		33	-	-
	34	BLU/YEL	Ground for sensor circuit		34	-	-

- | | | |
|---|--|--|
| 1. CKP sensor | 15. Immobilizer control module (if equipped) | 30. EGR valve (if equipped) |
| 2. CMP sensor | 16. Heater fan motor | 31. Ignition coil assembly (for No.2 and No.3 spark plugs) |
| 3. VSS | 17. Heater fan switch | 32. Ignition coil assembly (for No.1 and No.4 spark plugs) |
| 4. MAP sensor | 18. Fuel pressure control valve | 33. Stop lamp switch |
| 5. TP sensor | 19. Injector No. 1 | 34. Stop lamp |
| 6. ECT sensor | 20. Injector No.2 | 35. Lighting switch |
| 7. IAT sensor | 21. Injector No.3 | 36. Position lamp |
| 8. Heated oxygen sensor-1 (if equipped) | 22. Injector No.4 | 37. Rear defogger switch (if equipped) |
| 9. Heated oxygen sensor-2 (if equipped) | 23. EVAP canister purge valve | 38. Rear defogger (if equipped) |
| 10. Ignition adjusting resistor (if equipped) | 24. IAC valve | 39. Main relay |
| 11. CO adjusting register (if equipped) | 25. Radiator fan relay (if equipped) | 40. Ignition switch |
| 12. Fuel level sensor | 26. Radiator fan motor (if equipped) | 41. Starter magnetic switch |
| 13. Monitor connector (vehicle without EGR valve) | 27. Malfunction indicator lamp | 42. A/C control module (if equipped) |
| 14. Data link connector | 28. Fuel pump relay | |
| | 29. Fuel pump | |

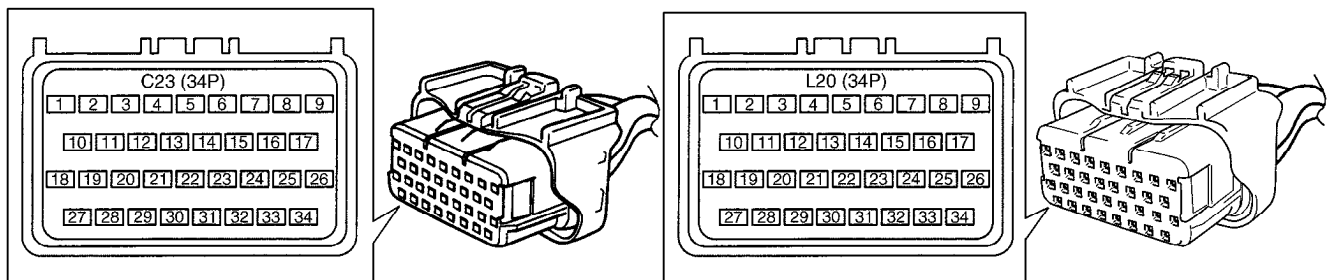

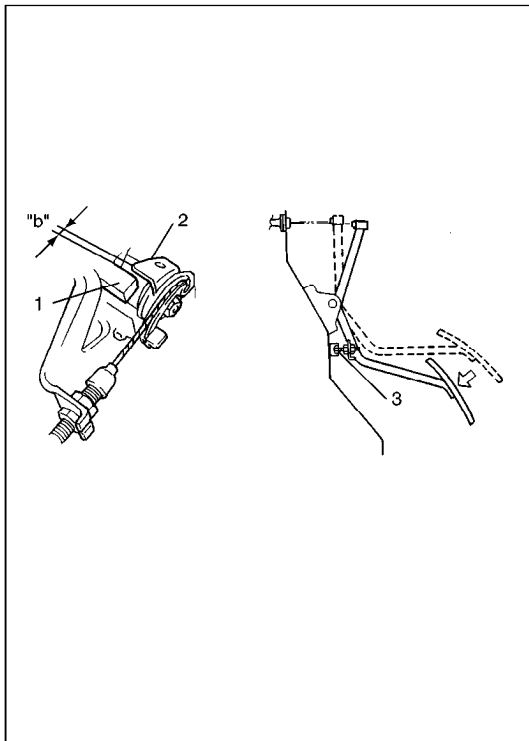
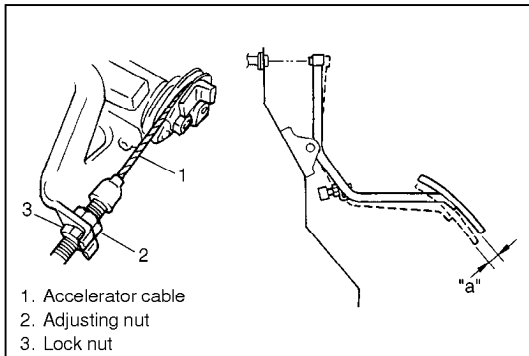

ON-VEHICLE SERVICE

ACCELERATOR CABLE ADJUSTMENT

- 1) With throttle valve closed, check accelerator pedal play which should be within following specification.

Pedal play "a": 2 – 7 mm (0.08 – 0.27 in.)

If measured value is out of specification, adjust it to specification with cable adjusting nut (2).

- 2) With accelerator pedal depressed fully, check clearance between throttle lever (2) and lever stopper (1) (throttle body) which should be within following specification.

**Clearance "a" : 0.5 – 2.0 mm (0.02 – 0.07 in.)
(With pedal depressed fully)**

If measured value is out of specification, adjust it to specification by changing height of pedal stopper bolt (3).

IDLE SPEED/IDLE AIR CONTROL (IAC) DUTY INSPECTION

Before idle speed/IAC duty check, make sure of the following.

- Lead wires and hoses of Electronic Fuel Injection and engine emission control systems are connected securely.
- Accelerator cable has some play, that is, it is not tight.
- Valve lash is checked and adjusted according to maintenance schedule.
- Ignition timing is within specification.
- All accessories (wipers, heater, lights, A/C, etc.) are out of service.
- Air cleaner has been properly installed and is in good condition.
- No abnormal air inhaling from air intake system.

After above items are all confirmed, check idle speed and IAC duty as follows.

NOTE:

Before starting engine, place transmission gear shift lever in "Neutral" and set parking brake and block drive wheels.

When using SUZUKI scan tool:

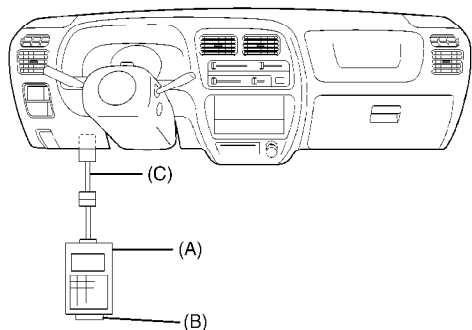

When using duty meter (Vehicle without EGR valve):

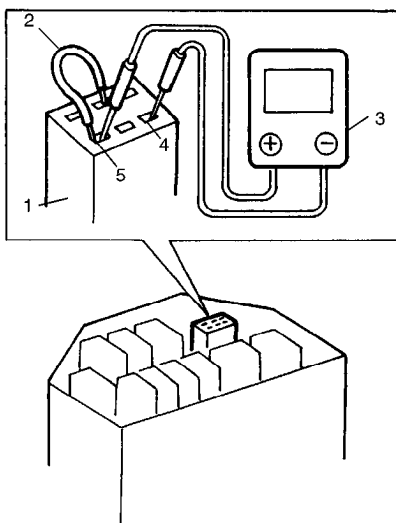

- 1) Connect SUZUKI scan tool to DLC with ignition switch OFF, if it is available.
- 2) Warm up engine to normal operating temperature.
- 3) Check engine idle speed and "IAC duty" as follows:

When using SUZUKI scan tool:

- a) Select "Data List" mode on scan tool to check "IAC duty".

(A): 09931-76011 (SUZUKI scan tool)

(B): Mass storage cartridge

(C): 09931-76030 (16/14 pin DLC cable)

When using duty meter (3) (Vehicle without EGR valve):

NOTE:

IAC duty can be checked using monitor connector only for vehicle not equipped with EGR valve.

- a) Set tachometer.
- b) Using service wire (2), ground "Diag. switch terminal" in monitor connector (1) and connect duty meter between "Duty output terminal (4)" and "Ground terminal (5)" of monitor connector (1).

If duty and/or idle speed is out of specifications, inspect idle air control system referring to Diagnostic Flow Table B-4 IDLE AIR CONTROL SYSTEM CHECK in Section 6.

ENGINE IDLE SPEED AND IAC DUTY	
A/C OFF	A/C ON
750 50 r/min (rpm) 5 – 25%	900 50 r/min (rpm)

NOTE:

Above duty values are ON duty (low voltage rate) meter indications.

- 4) Remove service wire from monitor connector.
- 5) Check that specified engine idle speed is obtained with A/C ON if vehicle is equipped with A/C.
If not, check A/C ON signal circuit and idle air control system.

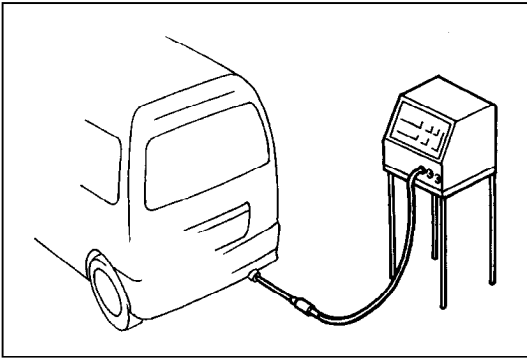

IDLE MIXTURE INSPECTION/ADJUSTMENT (VEHICLE WITHOUT HEATED OXYGEN SENSOR)

All vehicles not equipped with heated oxygen sensor are shipped with their CO% factory adjusted as follows.

Engine idle mixture (CO %)	0.5 – 1.5 % at specified idle speed
----------------------------	-------------------------------------

Idle mixture adjustment should never be changed from the original factory setting. However, if during diagnosis, the check indicates idle mixture to be the cause of a driver performance complaint or emission failure, the idle mixture can be adjusted using the following procedures.

NOTE:

For this inspection and adjustment, exhaust gas tester (CO meter) and engine tachometer are necessary.

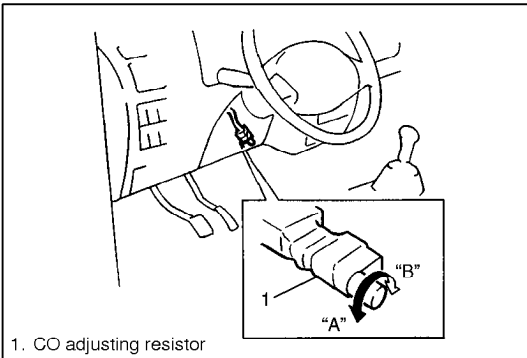

- 1) Check idle speed according to "Idle Speed Inspection" section.
- 2) Using exhaust gas tester, check that idle mixture CO% is within above specification. If it is out of specification, adjust it to specification by turning resistor knob.

NOTE:

CO adjusting resistor knob to "A" increases CO% (A/F mixture becomes rich) and turning it to "B" decreases CO% (A/F mixture becomes lean).

- 3) If idle mixture has been adjusted, confirm that idle speed is within specification.

AIR INTAKE SYSTEM

THROTTLE BODY

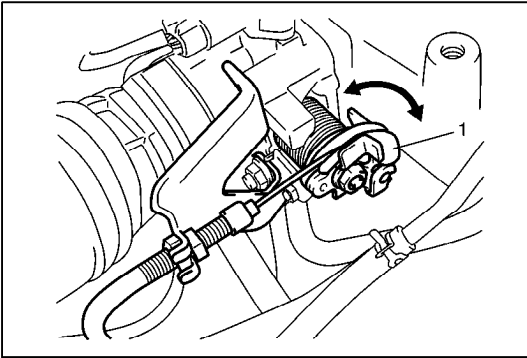
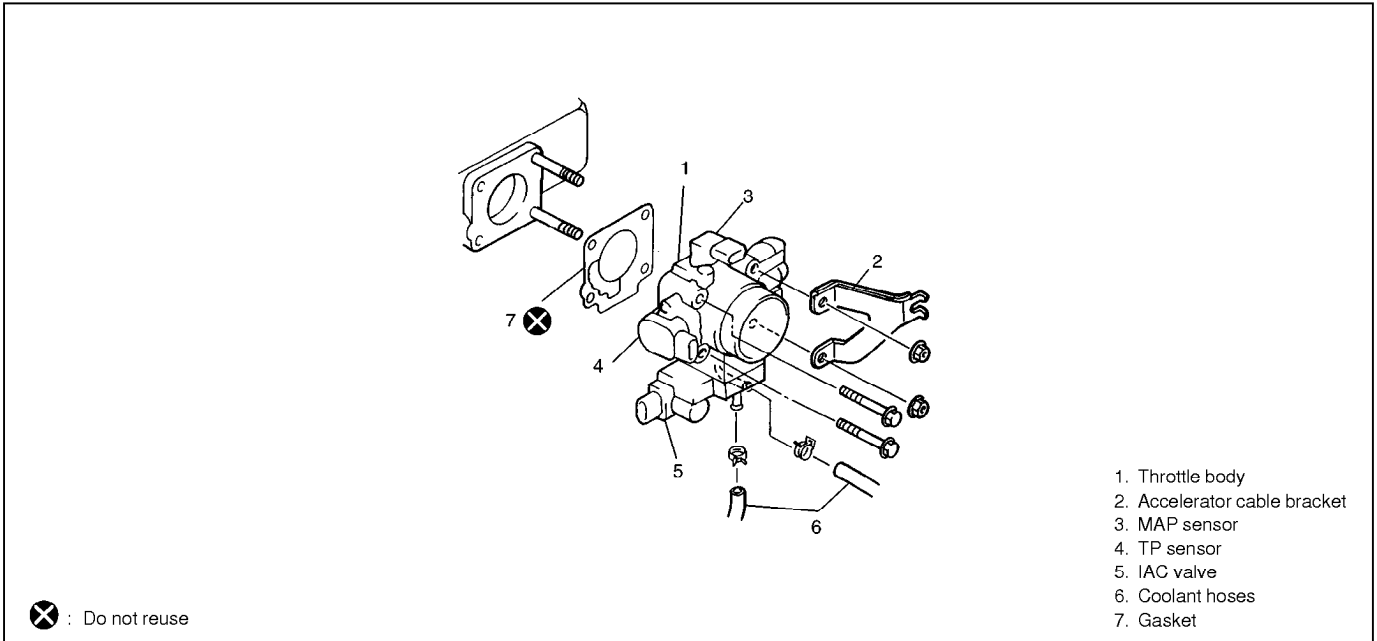

ON-VEHICLE INSPECTION

Check that throttle valve lever (1) moves smoothly.

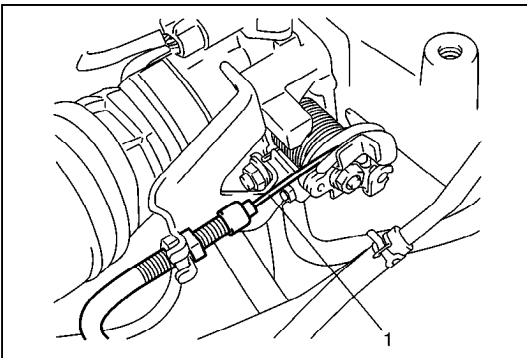

REMOVAL

- 1) Disconnect negative cable at battery.
- 2) Drain cooling system. Refer to Section 6B.
- 3) Disconnect accelerator cable (1) from throttle body.

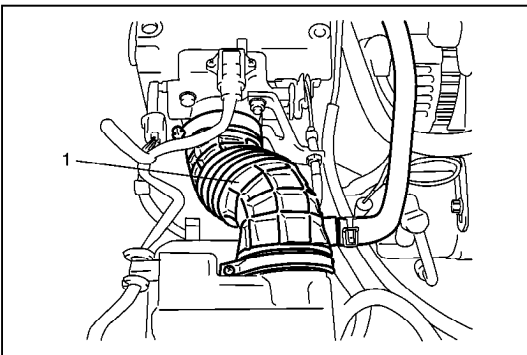

- 4) Disconnect air cleaner outlet hose (1) from throttle body.

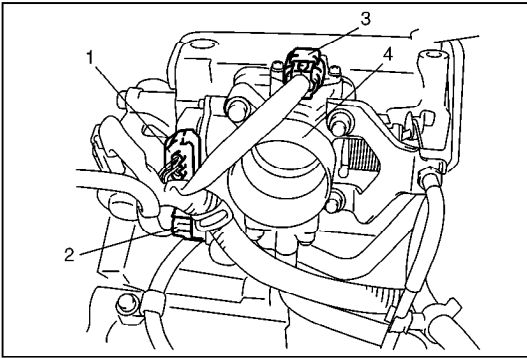

- 5) Disconnect electric connector from TP sensor (1), MAP sensor (3) and IAC valve (2).
- 6) Remove throttle body (4) from intake manifold.
- 7) Disconnect engine coolant hoses from throttle body.

DISASSEMBLY

NOTE:

While disassembling and assembling throttle body, use special care not to deform levers on throttle valve shaft or cause damage to any other parts.

- 1) Remove TP sensor, MAP sensor and IAC valve from throttle body.

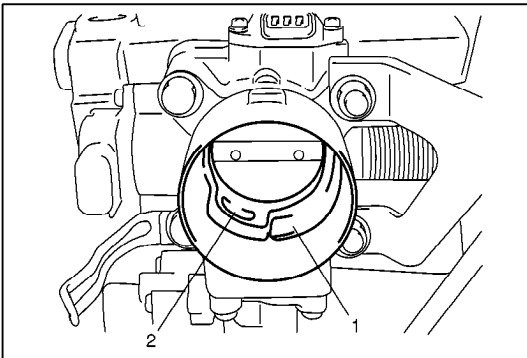

CLEANING

Clean throttle body bore (1) and idle air passage (2) by blowing compressed air.

NOTE:

TP sensor, MAP sensor, idle air control valve or other components containing rubber must not be placed in a solvent or cleaner bath. A chemical reaction will cause these parts to swell, harden or get distorted.

REASSEMBLY

- 1) Install IAC valve to throttle body referring to "IAC valve Installation" in this section.
- 2) Install TP sensor to throttle body referring to "TP sensor Installation" in this section.
- 3) Install MAP sensor to throttle body referring to "MAP sensor Installation" in this section.

INSTALLATION

- 1) Clean mating surfaces and install throttle body gasket to intake manifold.
Use new gasket.

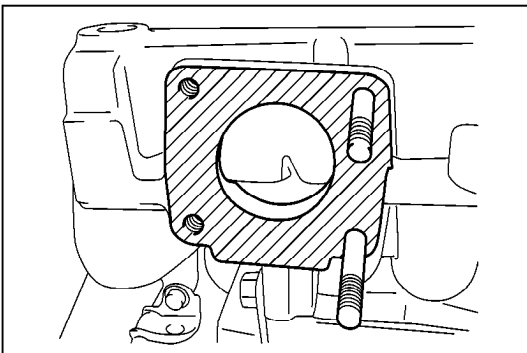

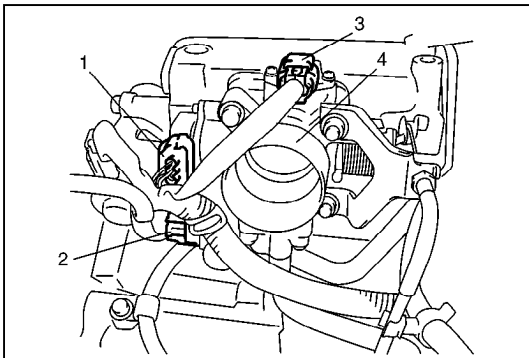

- 2) Connect engine coolant hoses.
- 3) Install throttle body (4) and accelerator cable bracket to intake manifold and tighten bolts and nuts to specified torque.
- 4) Connect connectors to TP sensor (1), MAP sensor (3) and IAC valve (2) securely.

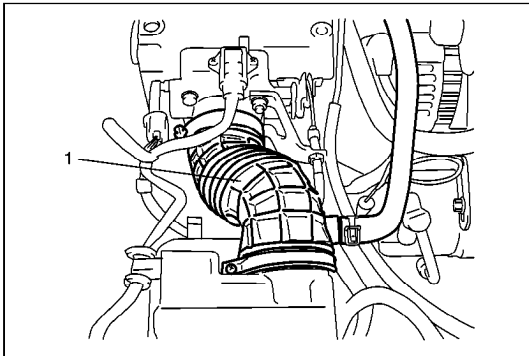

- 5) Install air cleaner outlet hose (1) and pipe.
- 6) Connect accelerator cable and adjust cable play to specification. Refer to "Accelerator Cable Adjustment" in this section.
- 7) Refill cooling system. Refer to Section 6B.
- 8) Connect negative cable at battery.

IDLE AIR CONTROL VALVE (IAC VALVE)**REMOVAL**

- 1) Remove throttle body from intake manifold referring to "Throttle Body Removal" in this section.
- 2) Remove IAC valve from throttle body.

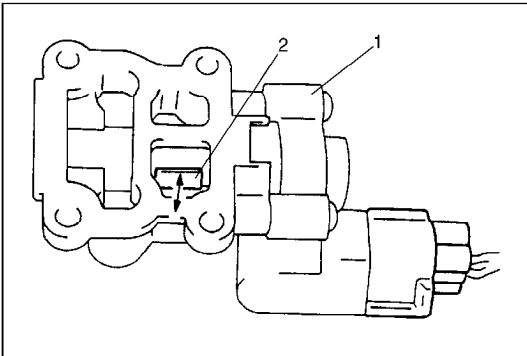
**INSPECTION**

- 1) Connect each connector to IAC valve (1), TP sensor and MAP sensor.
- 2) Check that rotary valve (2) of IAC valve opens and closes once and then stops in about 60 ms as soon as ignition switch is turned ON.

NOTE:

- This check should be performed by two people, one person turns on ignition switch while the other checks valve operation.
- As valve operation is momentary, it may be overlooked. To prevent this, perform this operation check 3 times or more continuously.

If rotary valve of IAC valve does not operate at all, check wire harness for open and short. If wire harness is in good condition, replace IAC valve and recheck.

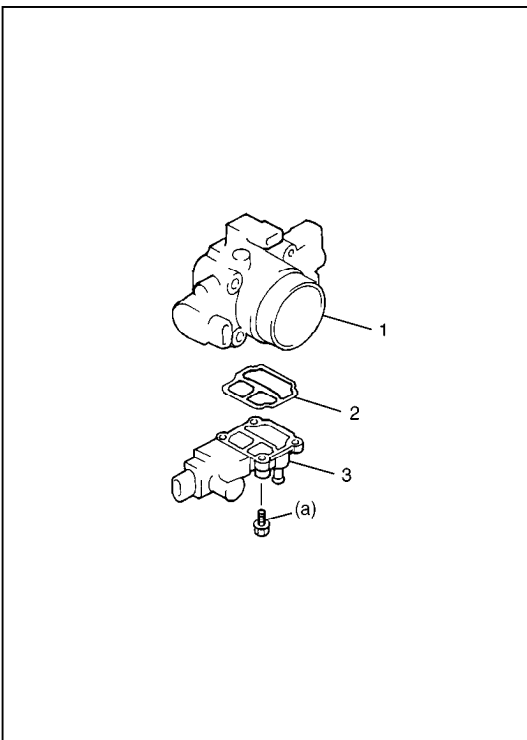
**INSTALLATION**

- 1) Install new O-ring (2) to IAC valve (3).
- 2) Install IAC valve (3) to throttle body (1).
Tighten IAC valve screws to specified torque.

Tightening Torque

(a): 3.5 N·m (0.35 kg-m, 2.5 lb-ft)

- 3) Install throttle body to intake manifold referring to "Throttle Body Installation" in this section.

FUEL DELIVERY SYSTEM

FUEL PRESSURE INSPECTION

WARNING:

Be sure to perform work in a well-ventilated area and away from any open flames, or there is a risk of a fire breaking out.

- 1) Relieve fuel pressure in fuel feed line referring to "Fuel Pressure Relief Procedure" in Section 6.
- 2) Disconnect fuel feed hose from fuel delivery pipe.

CAUTION:

A small amount of fuel may be released when fuel hose is disconnected. Place container under the joint with a shop cloth so that released fuel is caught in container or absorbed in cloth. Place that cloth in an approved container.

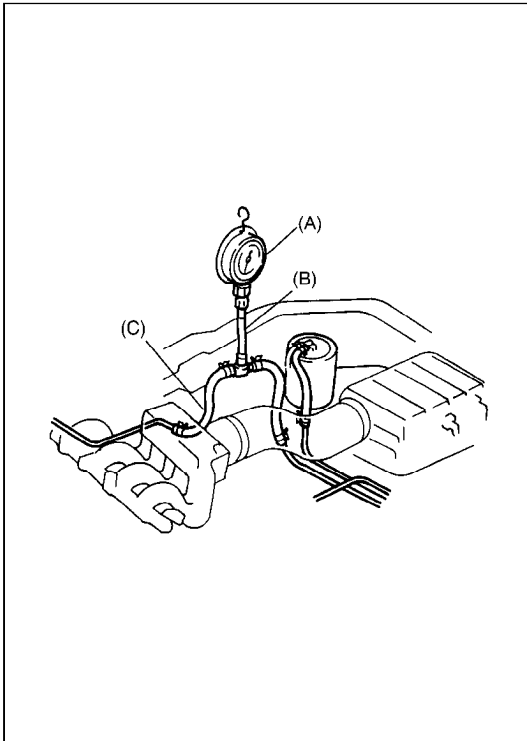

- 3) Connect special tools and hose between fuel delivery pipe and fuel feed hose as shown in figure, and clamp hoses securely to ensure no leaks occur during checking.

Special Tool

(A): 09912-58441

(B): 09912-58431

(C): 09912-58490

- 4) Check that battery voltage is above 11 V.

CONDITION	FUEL PRESSURE
With fuel pump operating and engine stopped	270 – 310 kPa 2.7 – 3.1 kg/cm ² 38.4 – 44.0 psi
At specified idle speed	210 – 260 kPa 2.1 – 2.6 kg/cm ² 29.8 – 37.0 psi
With 1 min. after engine (fuel pump) stop (Pressure reduces as time passes)	over 250 kPa 2.5 kg/cm ² 35.6 psi

- 5) Turn ignition switch ON to operate fuel pump and after 2 seconds turn it OFF. Repeat this 3 or 4 times and then check fuel pressure.
- 6) Start engine and warm it up to normal operating temperature.
- 7) Measure fuel pressure at idling.

If measured pressure doesn't satisfy specification, refer to "Diagnostic Flow Table B-3" in "Engine Diagnosis" section and check each possibly defective part. Replace if found defective.

- 8) After checking fuel pressure, remove fuel pressure gauge.

CAUTION:

As fuel feed line is still under high fuel pressure, make sure to release fuel pressure according to following procedures.

- Place fuel container under joint.
- Cover joint with rag and loosen joint nut slowly to release fuel pressure gradually.

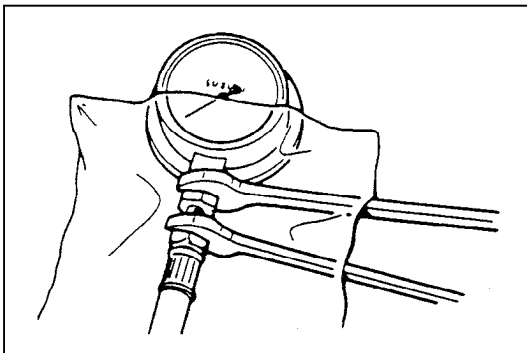

- 9) Remove special tools from fuel delivery pipe.
- 10) Connect fuel feed hose to fuel delivery pipe and clamp it securely.
- 11) With engine "OFF" and ignition switch "ON", check for fuel leaks.

FUEL PUMP

ON-VEHICLE INSPECTION

CAUTION:

When fuel filler cap is removed in any procedure, work must be done in a well-ventilated area, keep away from any open flames and without smoking.

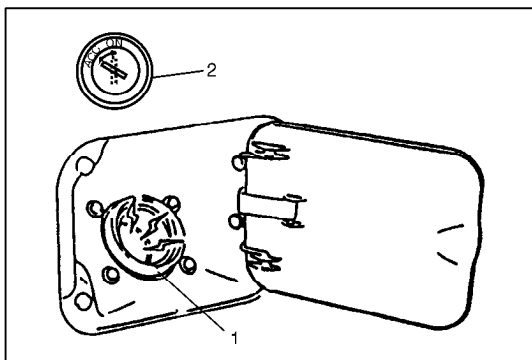

- 1) Remove filler cap and turn ON ignition switch (2). Then fuel pump operating sound should be heard from fuel filler (1) for about 2 seconds and stop. Be sure to reinstall fuel filler cap after checking.

If above check result is not satisfactory, advance to "Diagnostic Flow Table B-2" in Section 6.

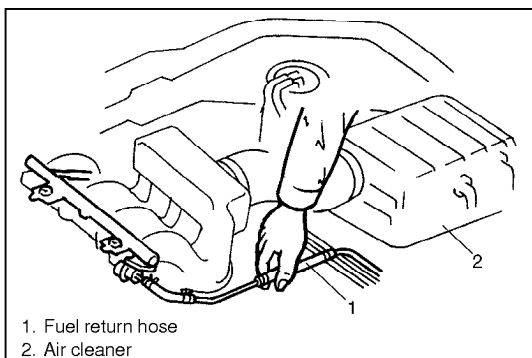

1. Fuel return hose
2. Air cleaner

- 2) Turn OFF ignition switch and leave over 10 minutes as it is.
- 3) Fuel pressure should be felt at fuel feed hose (1) for 2 seconds after ignition switch ON.

If fuel pressure is not felt, advance to "Diagnostic Flow Table B-3" in Section 6.

REMOVAL

Remove fuel tank from body according to procedure described in Section 6C and remove fuel pump from fuel tank.

INSPECTION

Check fuel pump filter for evidence of dirt and contamination. If present, clean and check for presence of dirt in fuel tank.

INSTALLATION

- 1) Install fuel pump to its bracket.
- 2) Install fuel pump to fuel tank and then install fuel tank to body according to procedure described in Section 6C.

FUEL PRESSURE REGULATOR**ON-VEHICLE INSPECTION**

Perform fuel pressure inspection according to procedure described in "Fuel Pressure Inspection" in this section.

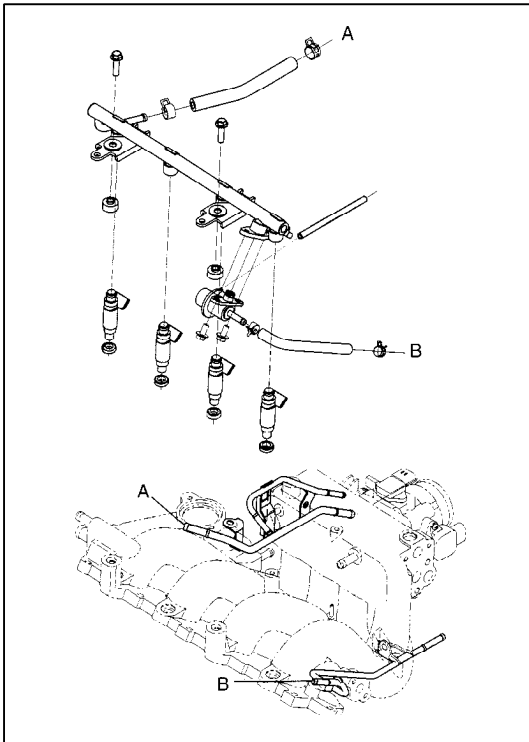
**REMOVAL**

- 1) Relieve fuel pressure according to procedure described on Section 6.
- 2) Disconnect battery negative cable from battery.
- 3) Disconnect fuel injector connectors from injectors.
- 4) Disconnect vacuum hose from fuel pressure regulator.
- 5) Remove fuel delivery pipe from intake manifold.
- 6) Remove fuel injectors from fuel delivery pipe.

CAUTION:

A small amount of fuel may be released when it is from delivery pipe.

Place a shop cloth under delivery pipe so that released fuel is absorbed in it.

- 7) Remove fuel pressure regulator from fuel delivery pipe.
- 8) Disconnect fuel return hose from fuel pressure regulator.

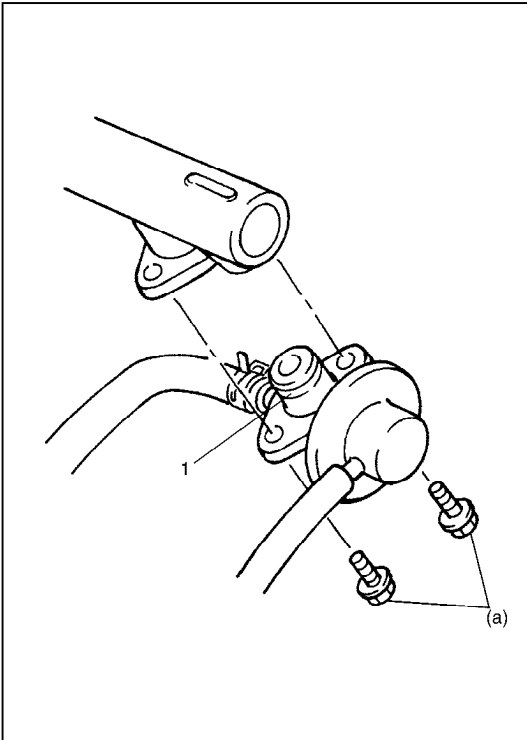

INSTALLATION

For installation, reverse removal procedure and note following precautions.

- Use new O-ring (1).
- Apply thin coat of gasoline to O-ring to facilitate installation.
- Tighten fuel pressure regulator bolts to specified torque.

Tightening Torque

(a): 10 N·m (1.0 kg-m, 7.5 lb-ft)

- With engine "OFF" and the ignition switch ON position, check for fuel leaks around fuel line connection.

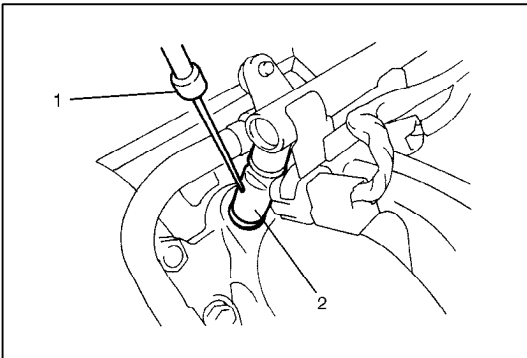

FUEL INJECTOR

ON-VEHICLE INSPECTION

- 1) Using sound scope (1) or such, check operating sound of injector (2) when engine is running or cranking.
Cycle of operating sound should vary according to engine speed.
If no sound or an unusual sound is heard, check injector circuit (wire or connector) or injector (2).

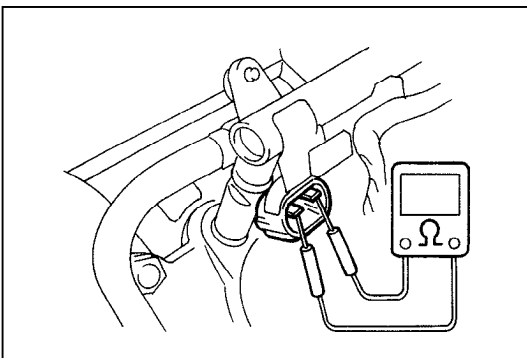

- 2) Disconnect connector (1) from injector, connect ohmmeter between terminals of injector and check resistance.

Resistance of injector: 10 – 15 Ω at 20°C, 68°F

If resistance is out of specification, replace.

- 3) Connect connector (1) to injector securely.

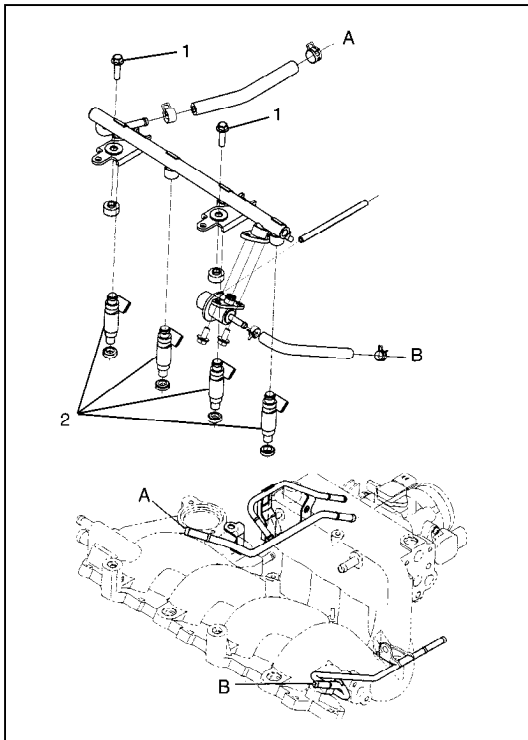
**REMOVAL**

- 1) Relieve fuel pressure according to procedure described in Section 6.
- 2) Disconnect battery negative cable at battery.
- 3) Disconnect fuel injector couplers and release wire harness from clamps.
- 4) Remove fuel delivery pipe bolts (1).
- 5) Remove fuel injector(s) (2) from delivery pipe and intake manifold.

CAUTION:

A small amount of fuel may come out after removal of fuel injectors, cover them with shop cloth.

INSPECTION**WARNING:**

As fuel is injected in this inspection, perform in a well ventilated area and away from open flames. Use special care to prevent sparking when connecting and disconnecting test lead to and from battery.

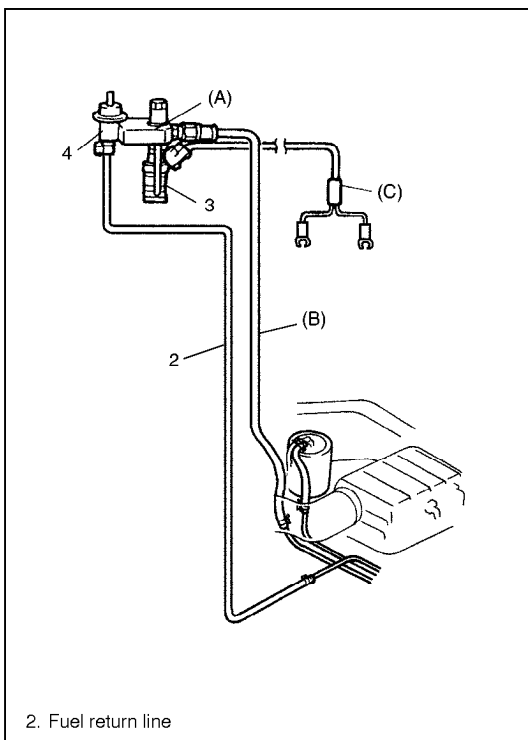

- 1) Install injector (3) and fuel pressure regulator (4) to special tool (injector checking tool).

Special Tool

(A): 09912-58421

- 2) Connect special tools (hose and attachment) to fuel feed hose (1) of vehicle.

Special Tool

(B): 09912-58431

- 3) Connect special tool (test lead) to injector.

Special Tool

(C): 09930-88530

When using SUZUKI scan tool :

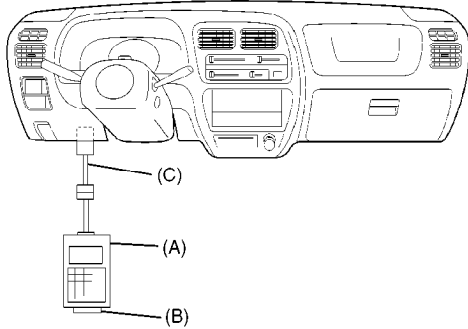

Without using SUZUKI scan tool :

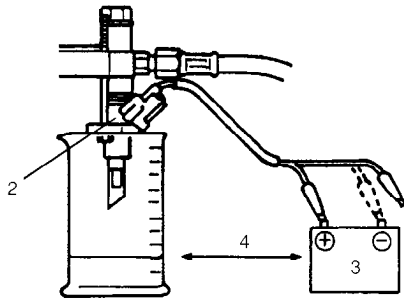
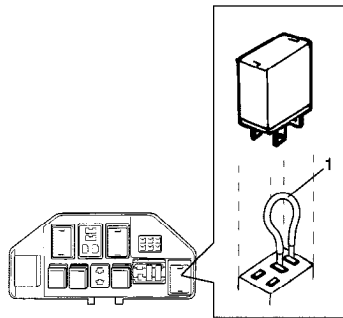

4. Keep as far apart as possible

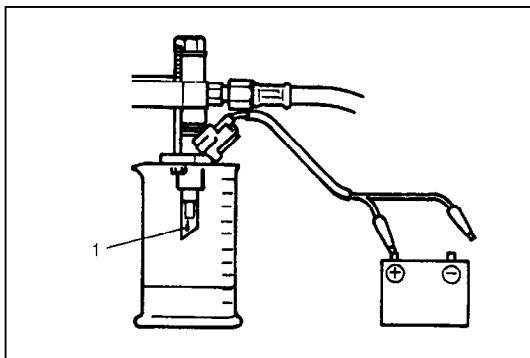

- 4) Install suitable vinyl tube onto injector nozzle to prevent fuel from splashing out when injecting.
- 5) Put graduated cylinder under injector as shown.
- 6) Operate fuel pump and apply fuel pressure to injector as follows:

When using SUZUKI scan tool (for vehicle with EGR valve):

- a) Connect SUZUKI scan tool to DLC with ignition switch OFF.
- b) Turn ignition switch ON, clear DTC and select "MISC TEST" mode on SUZUKI scan tool.
- c) Turn fuel pump ON by using SUZUKI scan tool.

(A): 09931-76011 (SUZUKI scan tool)

(B): Mass storage cartridge

(C): 09931-76030 (16/14 pin DLC cable)

Without using SUZUKI scan tool :

- a) Remove fuel pump relay from connector.
- b) Connect two terminals of relay connector using service wire (1) as shown in figure.

CAUTION:

Check to make sure that connection is made between correct terminals. Wrong connection can cause damage to ECM, wire harness, etc.

- c) Turn ignition switch ON.
- 7) Apply battery voltage (3) to injector (2) for 15 seconds and measure injected fuel volume with graduated cylinder. Test each injector two or three times. If not within specification, replace injector.

Injected fuel volume:

43 – 47 cc/15 sec. (1.45/1.51 – 1.58/1.65 US/Imp. oz/15 sec.)

- 8) Check fuel leakage from injector nozzle. Do not operate injector for this check (but fuel pump should be at work). If fuel leaks (1) more than following specifications, replace.

Fuel leakage (1): Less than 1 drop/min.

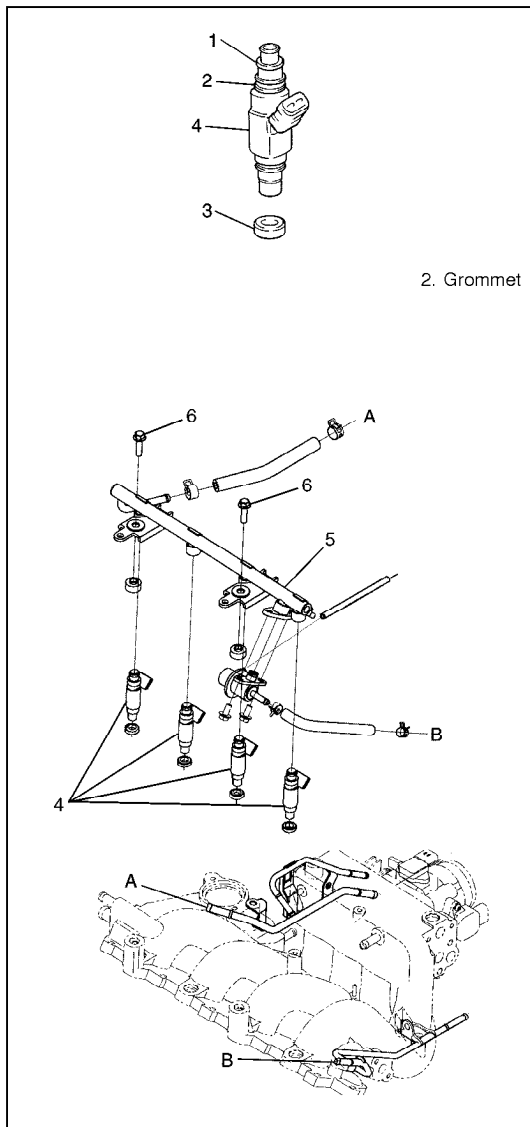

INSTALLATION

For installation, reverse removal procedure and note following precautions.

- Replace injector O-ring (1) with new one using care not to damage it.
- Check if cushion (3) is scored or damaged. If it is, replace with new one.
- Apply thin coat of fuel to O-rings (1) and then install injectors (4) into delivery pipe (5) and intake manifold. Make sure that injectors (4) rotate smoothly. If not, probable cause is incorrect installation of O-ring (1). Replace O-ring (1) with new one.
- Tighten delivery pipe bolts (6) and make sure that injectors (4) rotate smoothly.

Tightening Torque

(a): 23 N·m (2.3 kg-m, 17.0 lb-ft)

- After installation, with engine "OFF" and ignition switch "ON", check for fuel leaks around fuel line connection.

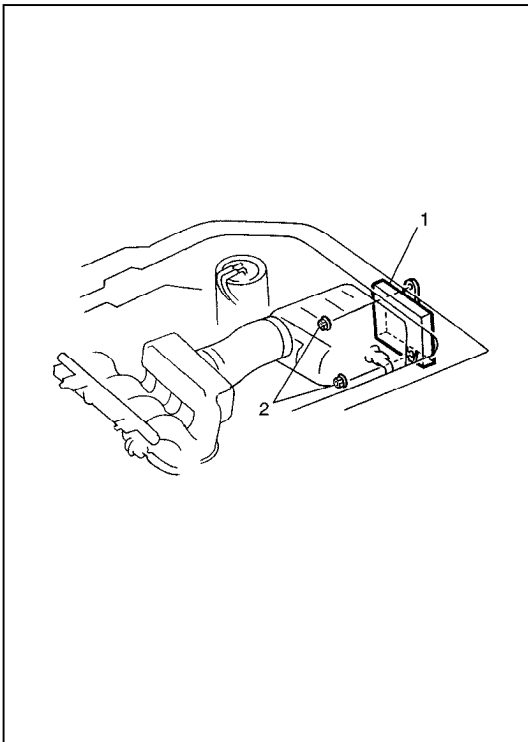

ELECTRONIC CONTROL SYSTEM ENGINE CONTROL MODULE (ECM)

CAUTION:

As ECM consists of precision parts, be careful not to expose it to excessive shock.

REMOVAL

- 1) Disconnect battery negative cable at battery.
- 2) Disable air bag system, refer to "DISABLING THE AIR BAG SYSTEM" in Section 10B if equipped.
- 3) Remove air cleaner case.
- 4) Disconnect ECM (1) connectors.
- 5) Loosen 2 nuts (2) and remove ECM.

INSTALLATION

Reverse removal procedure noting the following:
Connect connectors to ECM securely.

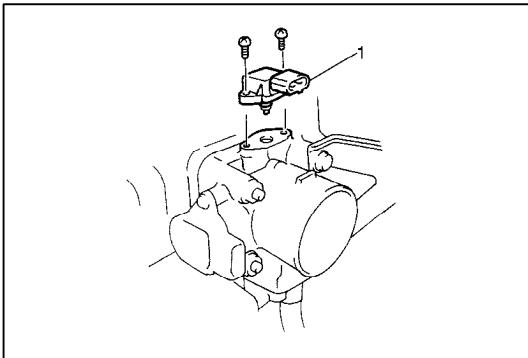

MANIFOLD ABSOLUTE PRESSURE SENSOR (MAP SENSOR)

REMOVAL

- 1) Disconnect negative cable at battery.
- 2) Disconnect MAP sensor connector.
- 3) Remove MAP sensor (1) from throttle body.

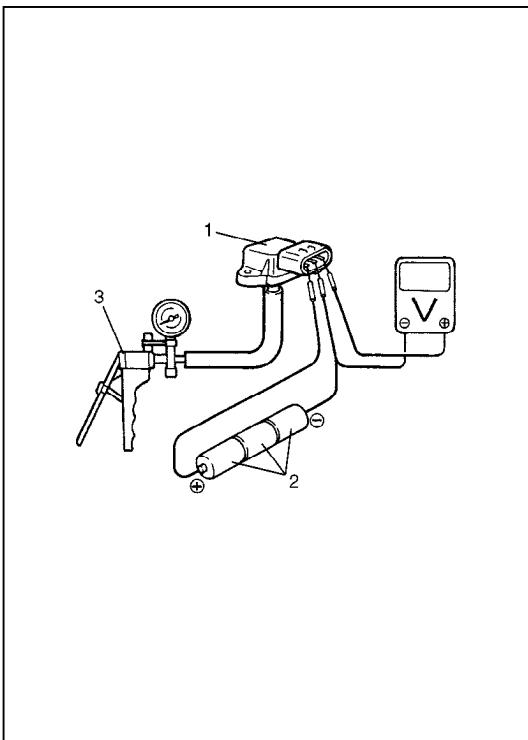

INSPECTION

- 1) Arrange 3 new 1.5V batteries (2) in series (check that total voltage is 4.5–5.0V) and connect its positive terminal to "Vin" terminal of sensor and negative terminal to "Ground" terminal. Then check voltage between "Vout" and "Ground".
Also, check if voltage reduces when vacuum is applied up to 400mmHg by using vacuum pump (3).

Output voltage (When input voltage 4.5 – 5.5 V, ambient temp. 20 – 30°C, 68 – 86°F)

ALTITUDE (Reference)		BAROMETRIC PRESSURE		OUTPUT VOLTAGE
(ft)	(m)	(mmHg)	(kPa)	(V)
0	0	760	100	3.5 – 3.7
2000	610	707	93	3.3 – 3.5
5000	1524	634	83	3.0 – 3.2
8000	2438	567	75	2.7 – 3.0
10000	3048	526	69	2.6 – 2.8

If check result is not satisfactory, replace MAP sensor (1).

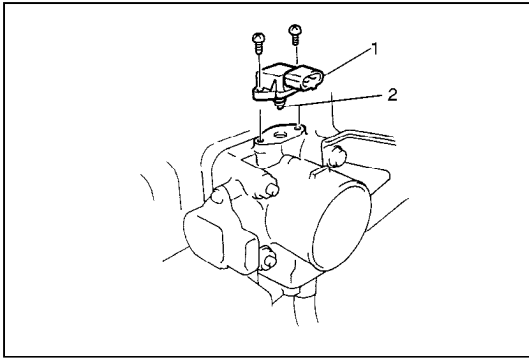

INSTALLATION

Reverse removal procedure noting the followings:

- Replace O-ring (2) with new one.
- Connect MAP sensor connector (1) securely.

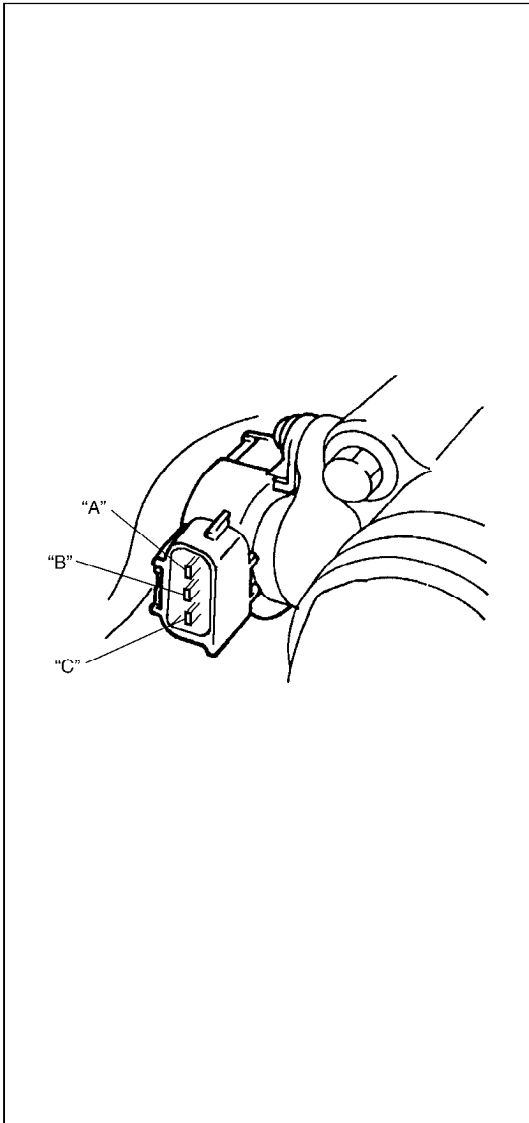

THROTTLE POSITION SENSOR (TP SENSOR) INSPECTION

- 1) Disconnect negative cable at battery and connector from TP sensor.
- 2) Using ohmmeter, check resistance between terminals under each condition given in table below.

TERMINALS	RESISTANCE	
Between "A" and "B" terminals	2.5 – 6.0 k Ω	
Between "A" and "C" terminals	Throttle valve is at idle position	0.17 – 11.4 k Ω
	Throttle valve is fully opened	1.72 – 15.50 k Ω

NOTE:

There should be more than 1.5 k Ω resistance difference between when throttle valve is at idle position and when it is fully open.

If check result is not satisfactory, replace TP sensor.

- 3) Connect TP sensor connector securely.
- 4) Connect negative cable to battery.

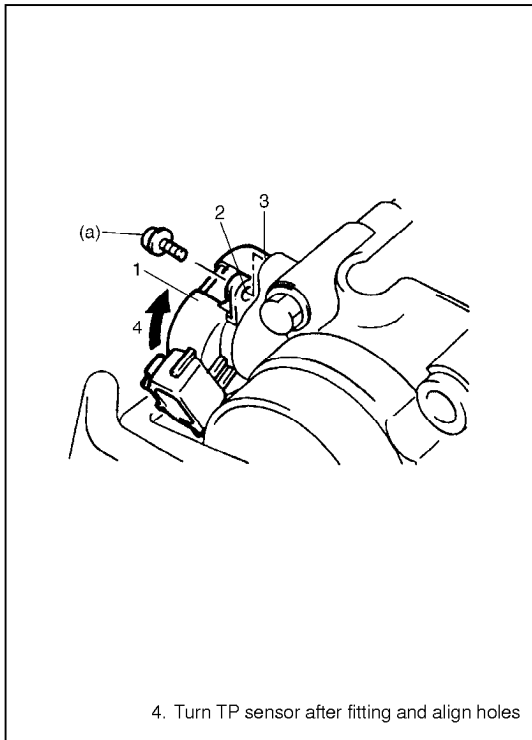

REMOVAL

- 1) Disconnect battery negative cable at battery.
- 2) Disconnect connector from TP sensor.
- 3) Remove TP sensor from throttle body.

INSTALLATION

- 1) Install TP sensor (1) to throttle body.
Fit TP sensor to throttle body in such way that its holes (3) are a little away from TP sensor screw holes (2) and turn TP sensor clockwise so that those holes align.

Tightening Torque

(a): 2.0 N·m (0.20 kg-m, 1.5 lb-ft)

- 2) Connect connector to TP sensor securely.
- 3) Connect battery negative cable to battery.

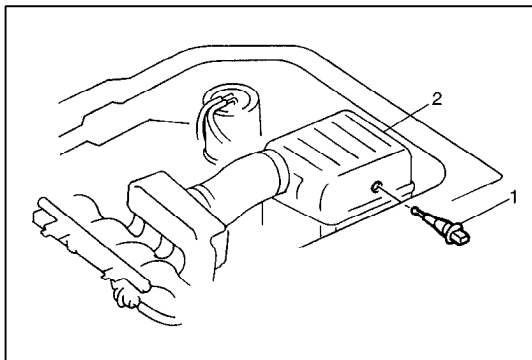

INTAKE AIR TEMPERATURE SENSOR (IAT SENSOR) REMOVAL

- 1) Disconnect battery negative cable at battery.
- 2) Disconnect connector from IAT sensor (1).
- 3) Remove IAT sensor (1) from air cleaner case (2).

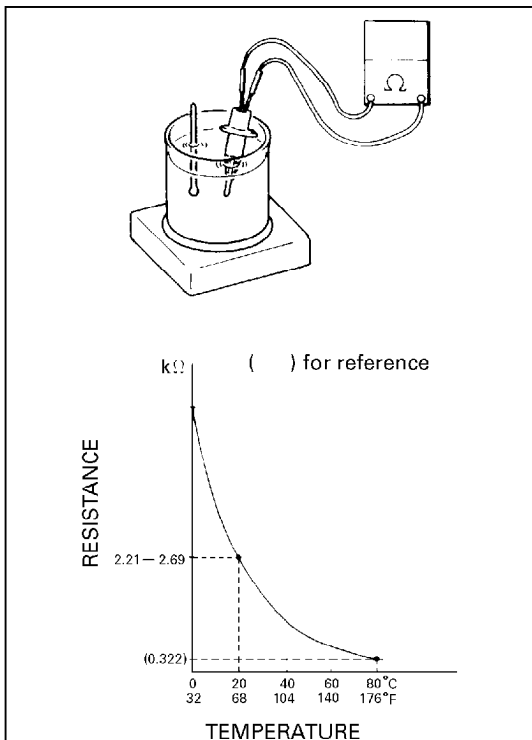

INSPECTION

Immerse temperature sensing part of IAT sensor in water (or ice) and measure resistance between sensor terminals while heating water gradually.

If measured resistance doesn't show such characteristic as shown in left figure, replace IAT sensor.

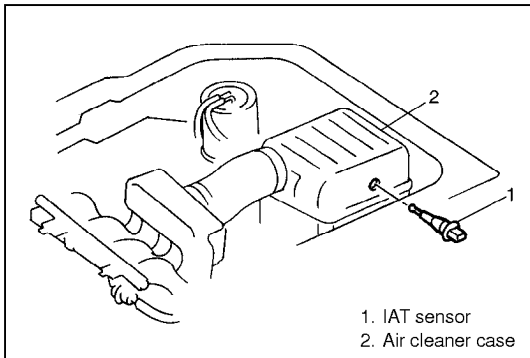

INSTALLATION

Reverse removal procedure noting the following.

- Clean mating surfaces of IAT sensor and air cleaner case.
- Connect IAT sensor connector (1) securely.

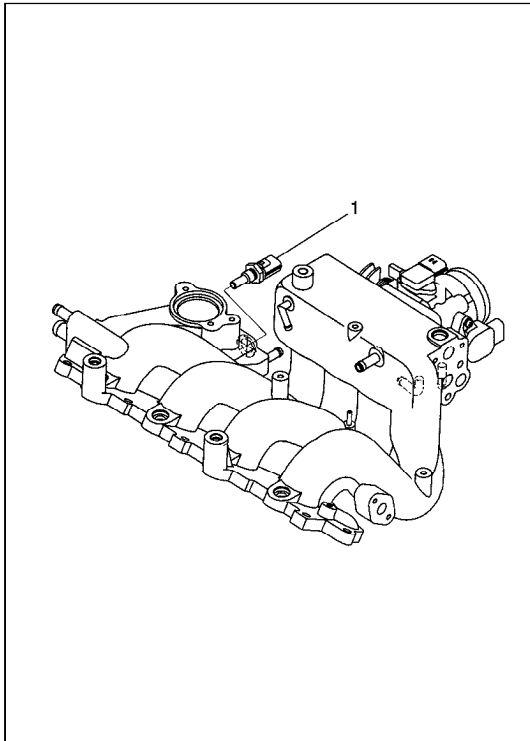

ENGINE COOLANT TEMPERATURE SENSOR (ECT SENSOR)

REMOVAL

- 1) Disconnect battery negative cable at battery.
- 2) Drain coolant referring to Section 6B.

WARNING:

To help avoid danger of being burned, do not remove radiator cap while engine and radiator are still hot. Scalding fluid and steam can be blown out under pressure if cap is taken off too soon.

- 3) Remove generator referring to Section 6H.
- 4) Disconnect connector from ECT sensor.
- 5) Remove ECT sensor (1) from intake manifold.

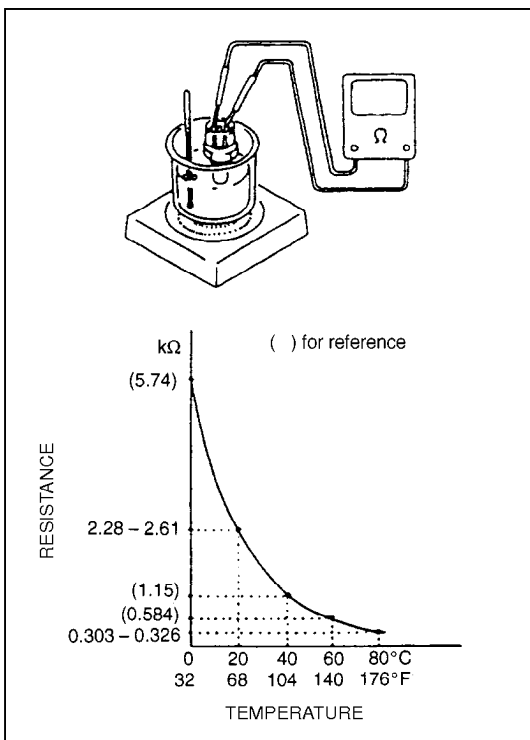

INSPECTION

Immerse temperature sensing part of ECT sensor (1) in water (or ice) and measure resistance between terminals while heating water gradually.

If measured resistance doesn't show such characteristic as shown, replace ECT sensor (1).

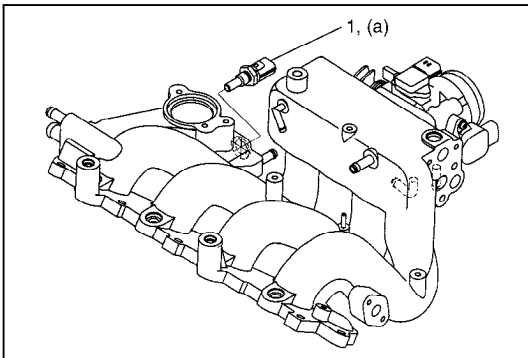

INSTALLATION

Reverse removal procedure noting the following:

- Clean mating surfaces of ECT sensor (1) and intake manifold.
- Replace O-ring with new one.
- Tighten ECT sensor (1) to specified torque.

Tightening Torque

(a): 15 N·m (1.5 kg-m, 11.5 lb-ft)

- Connect connector to ECT sensor (1) securely.
- Refill coolant referring to Section 6B.

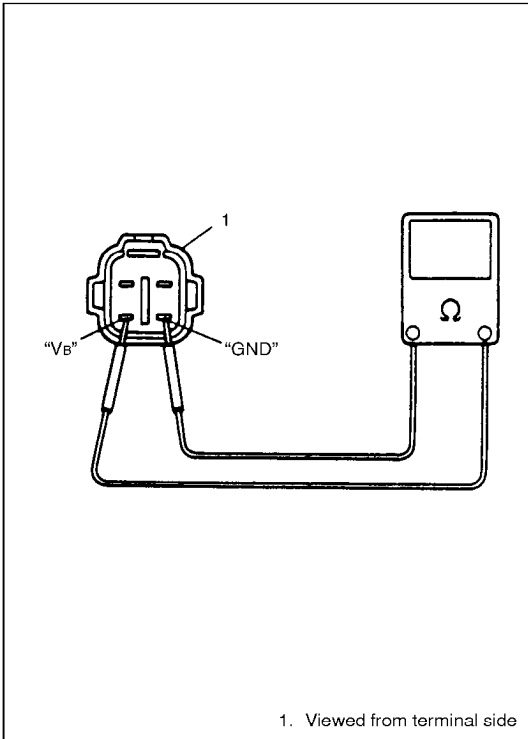

HEATED OXYGEN SENSOR (Sensor-1 and Sensor-2) (IF EQUIPPED)

OXYGEN SENSOR HEATER INSPECTION

- 1) Disconnect sensor connector.
- 2) Using ohmmeter, measure resistance between terminals "V_B" and "GND" of sensor connector.

NOTE :

Temperature of sensor affects resistance value largely.
Make sure that sensor heater is at correct temperature.

Resistance of oxygen sensor heater :

5.0 – 6.4 Ω at 20°C, 68°F for HO2S-1

11.7 – 14.3 Ω at 20°C, 68°F for HO2S-2

If found faulty, replace oxygen sensor.

- 3) Connect sensor connector securely.

REMOVAL

WARNING:

To avoid danger of being burned, do not touch exhaust system when system is hot. Oxygen sensor removal should be performed when system is cool.

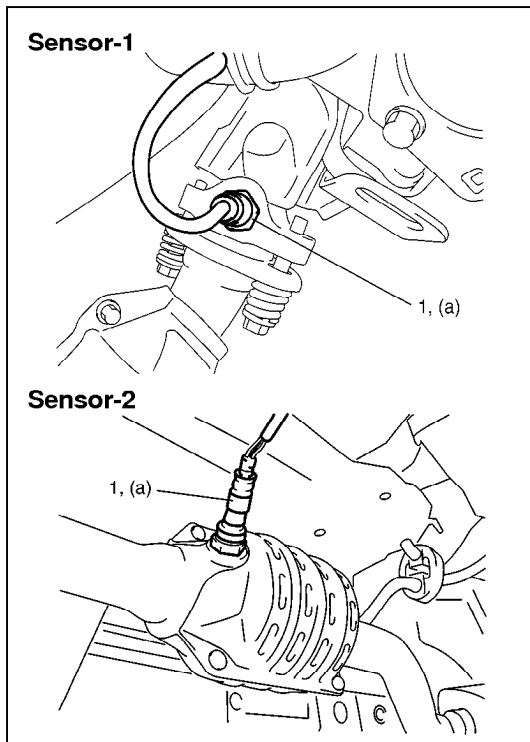

- 1) Disconnect negative cable at battery.
- 2) Hoist vehicle when removing sensor-2.
- 3) Disconnect connector of heated oxygen sensor and release its wire harness from clamp.
- 4) Remove heated oxygen sensor (1) from exhaust manifold or exhaust No.1 pipe.

INSTALLATION

Reverse removal procedure noting the following.

- Tighten heated oxygen sensor (1) to specified torque.

Tightening Torque for heated oxygen sensor

(a): 45 N·m (4.5 kg-m, 32.5 lb-ft)

- Connect connector of heated oxygen sensor (2) and clamp wire harness securely.
- After installing heated oxygen sensor (2), start engine and check that no exhaust gas leakage exists.

CAMSHAFT POSITION SENSOR (CMP SENSOR)

INSPECTION

Check CMP sensor referring to DTC P0340 (No. 15) Diag. Flow Table in Section 6. If malfunction is found, replace.

REMOVAL

- 1) Disconnect negative cable at battery.
- 2) Disconnect connector from CMP sensor.
- 3) Remove CMP sensor from sensor case.

INSTALLATION

- 1) Check that O-ring (2) is free from damage.
- 2) Check that CMP sensor (1) and signal rotor tooth are free from any metal particles and damage.
- 3) Install CMP sensor to sensor case.

Tightening Torque

(a): 10 N·m (1.0 kg-m, 7.5 lb-ft)

- 4) Connect connector to it securely.
- 5) Connect negative cable to battery.

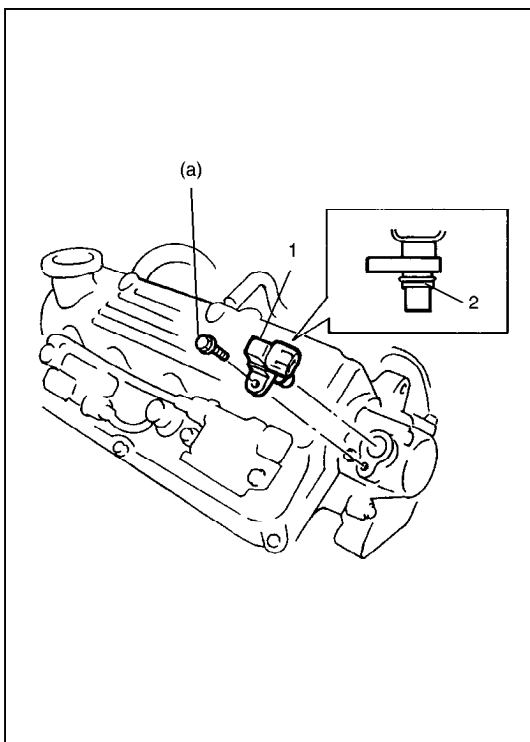

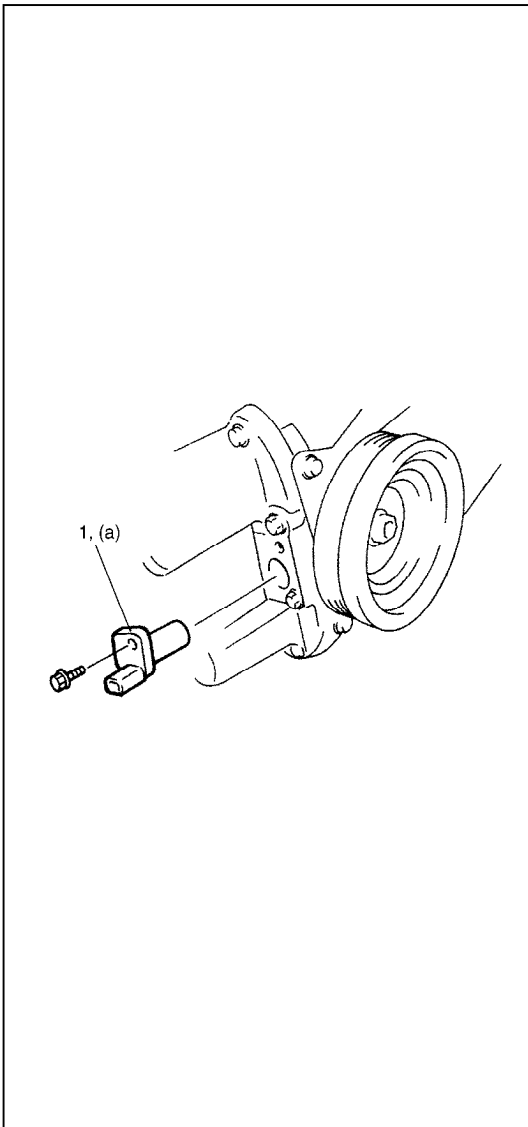

CRANKSHAFT POSITION SENSOR (CKP SENSOR) INSPECTION

Check CKP sensor referring to step 1 and 2 of DTC P0335 (No.23) Flow Table in Section 6. If malfunction is found, replace.

REMOVAL

- 1) Disconnect negative cable at battery.
- 2) Disconnect connector from CKP sensor (1).
- 3) Remove CKP sensor (1) from oil pan.

INSTALLATION

- 1) Check to make sure that CKP sensor (1) and pulley tooth is free from any metal particles and damage.
- 2) Install CKP sensor (1) to oil pan.

Tightening Torque

(a): 10 N·m (1.0 kg·m, 7.2 lb-ft)

CAUTION:

Be sure to tighten to specified torque. CKP sensor will be deformed if overtightened and correct CKP sensor signal will not be fed if loosened.

- 3) Connect connector to it securely.
- 4) Connect negative cable to battery.

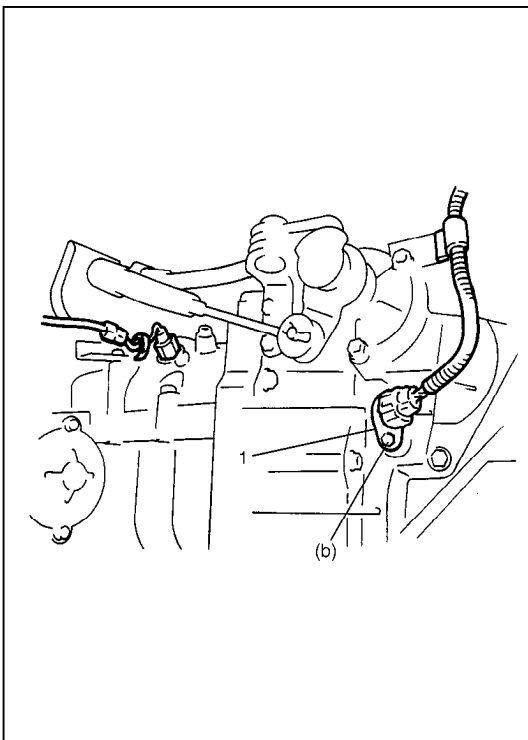

VEHICLE SPEED SENSOR (VSS) INSPECTION

Check vehicle speed sensor referring to step 3 of DTC P0500 (No.16) Flow Table. If malfunction is found, replace.

REMOVAL

- 1) Disconnect negative cable at battery.
- 2) Disconnect VSS connector.
- 3) Remove VSS (1) from transmission.

INSTALLATION

Reverse removal procedure noting the following.
Tighten VSS to specified torque.

Tightening Torque

(a): 5 N·m (0.5 kg·m, 3.6 lb-ft)

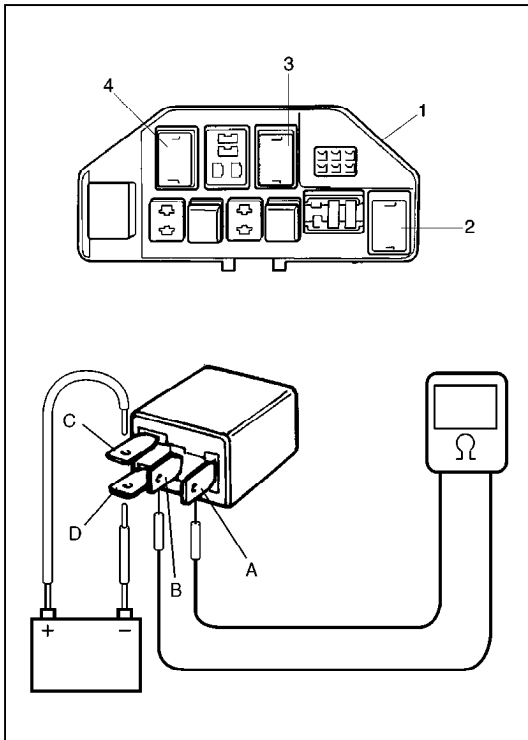

MAIN RELAY, FUEL PUMP RELAY AND RADIATOR FAN CONTROL RELAY

INSPECTION

- 1) Disconnect negative cable at battery.
- 2) Remove main relay (3), fuel pump relay (2) and radiator fan control relay (4) from main fuse box (1).
- 3) Check that there is no continuity between terminal "A" and "B". If there is continuity, replace relay.
- 4) Connect battery positive (+) terminal to terminal "C" of relay. Connect battery negative (-) terminal "D" of relay. Check continuity between terminal "A" and "B". If there is no continuity when relay is connected to the battery, replace relay.

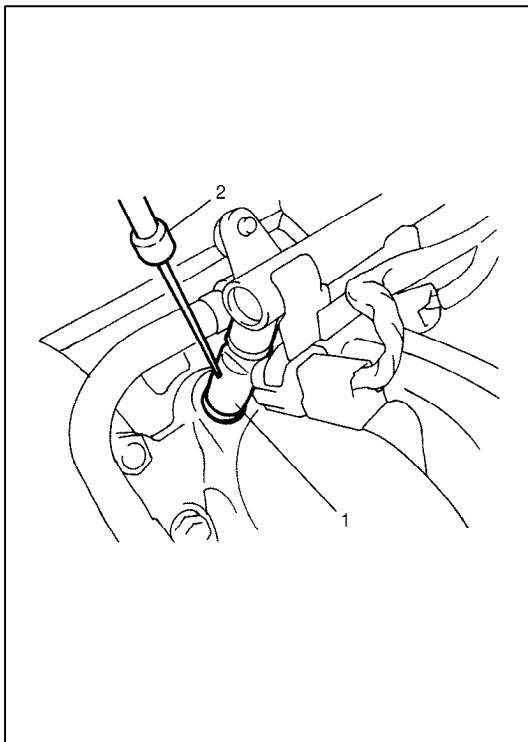

FUEL CUT OPERATION

INSPECTION

NOTE:

Before inspection, check to make sure that gear shift lever is in neutral position, A/C is OFF and that parking brake lever is pulled all the way up.

- 1) Warm up engine to normal operating temperature.
- 2) While listening to sound of injector (1) by using sound scope (2) or such, increase engine speed to higher than 3,000 r/min.
- 3) Check to make sure that sound to indicate operation of injector stops when throttle valve is closed instantly and it is heard again when engine speed is reduced to less than about 2,000 r/min.

FUEL LEVEL SENSOR (GAUGE)

INSPECTION

Refer to Section 8.

REMOVAL/INSTALLATION

Refer to Section 6C.

RADIATOR FAN CONTROL SYSTEM SYSTEM INSPECTION

WARNING:

Keep hands, tools, and clothing away from radiator fan to help prevent personal injury. This fan is electric and can come on whether or not the engine is running. The fan can start automatically in response to the ECM (and ECT sensor) with the ignition switch in the "ON" position.

Check system for operation referring to Flow Table B-7 in Section 6.

If radiator fan fails to operate properly, check relay, radiator fan and electrical circuit.

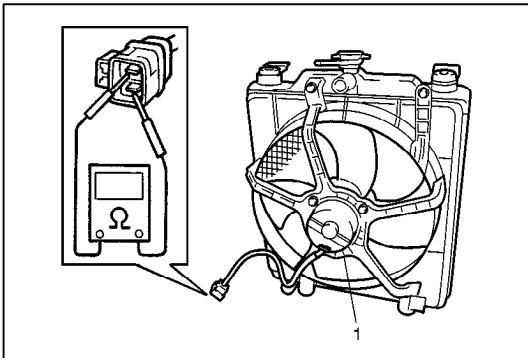

RADIATOR FAN INSPECTION

- 1) Check continuity between each two terminals.
If there is no continuity, replace radiator fan motor (1).

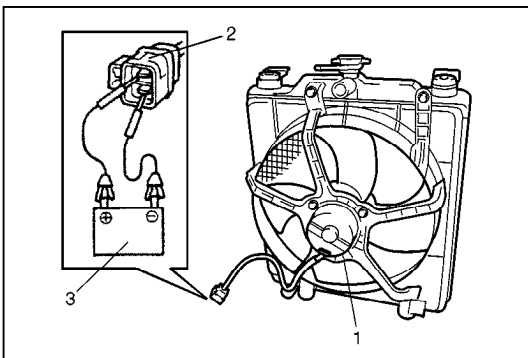

- 2) Connect battery (3) to radiator fan motor coupler (2) as shown in figure, then check that the radiator fan motor (1) operates smoothly.
If radiator fan motor does not operate smoothly, replace motor.

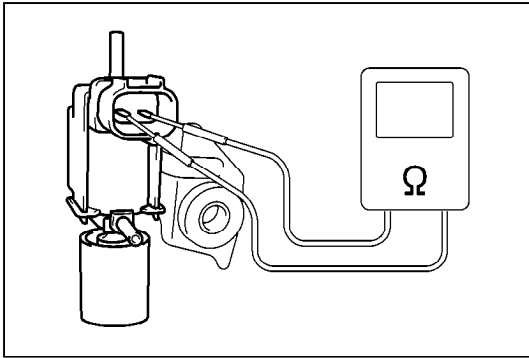

FUEL PRESSURE CONTROL VALVE INSPECTION

- 1) Disconnect negative cable at battery and connector from fuel pressure control valve.
- 2) Check resistance between two terminals of fuel pressure control valve.

**Resistance of fuel pressure control valve: 37 – 44 Ω
at 20°C (68°F)**

If resistance is as specified, proceed to next operation check.
If not, replace.

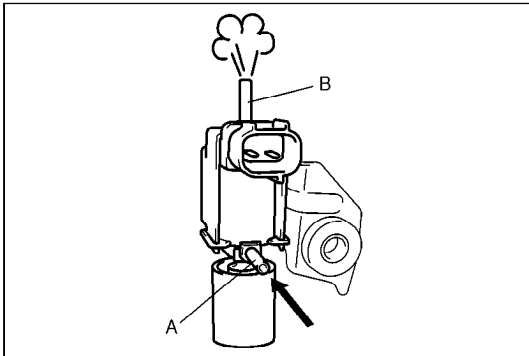

- 3) Disconnect hoses from intake manifold and fuel pressure regulator.
- 4) Blow into pipe "A". Air should come out of pipe "B" and not out of filter.

- 5) Connect 12 V – battery to fuel pressure control valve terminals. In this state, blow pipe "A".

Air should come out of filter and not out of pipe "B".

If check result is not as described, replace fuel pressure control valve.

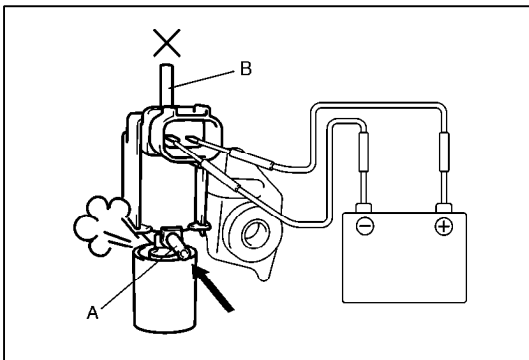

- 6) Connect hoses.

- 7) Connect fuel pressure control valve connector securely.

EMISSION CONTROL SYSTEM

EGR SYSTEM (IF EQUIPPED)

SYSTEM INSPECTION

- 1) Connect SUZUKI scan tool to DLC with ignition switch OFF.
- 2) Turn ignition switch ON and then select "DATA LIST" mode on scan tool.
- 3) Make sure that vehicle condition is as following.
 - Vehicle speed = 0 km/h (0 KPH)
 - Engine speed \leq 3000 rpm
- 4) Clear DTC by using "CLEAR INFO" mode.

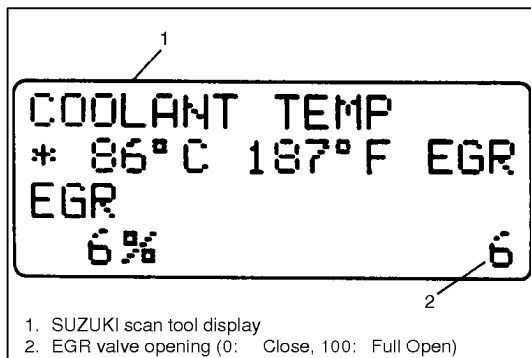

- 5) With engine idling (without depressing accelerator pedal), open EGR valve by using "STEP EGR" mode in "MISC TEST" menu. In this state, according as EGR valve opening increases engine idle speed drops. If not, possible cause is clogged EGR gas passage, stuck or faulty EGR valve, poor performance of ECT sensor or TP sensor or DTC and/or pending DTC is (are) stored in ECM memory.

REMOVAL

- 1) Disconnect negative cable at battery.
- 2) Disconnect EGR valve connector.
- 3) Remove EGR valve and gasket from intake manifold.
- 4) Remove EGR pipe.

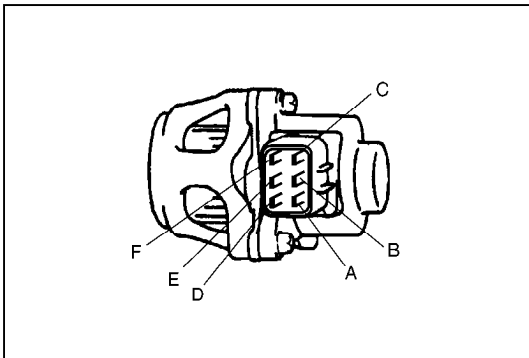

INSPECTION

- 1) Check resistance between following terminals of EGR valve (1) in each pair.

Terminal	Standard resistance
A – B	20 – 24 Ω at 20°C, 68°F
C – B	
F – E	
D – E	

If found faulty, replace EGR valve assembly.

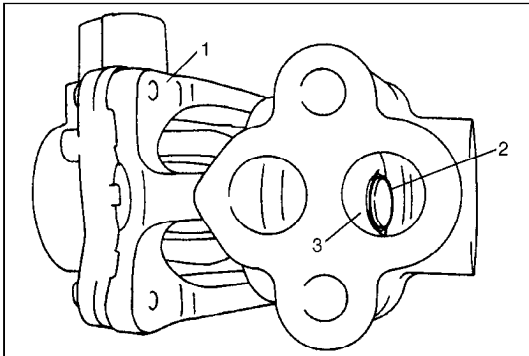

- 2) Remove carbon from EGR valve (1) gas passage.

NOTE:

Do not use any sharp-edged tool to remove carbon. Be careful not to damage or bend EGR valve, valve seat and rod.

- 3) Inspect valve (2), valve seat (3) and rod for fault, cracks, bend or other damage.

If found faulty, replace EGR valve assembly.

INSTALLATION

Reverse removal procedure noting following.

- Clean mating surface of valve and intake manifold.
- Use new gaskets.

EVAPORATIVE EMISSION (EVAP) CONTROL SYSTEM

EVAP CANISTER PURGE INSPECTION

NOTE:

Before inspection, check to make sure that gear shift lever is in neutral position and that parking brake lever is pulled all the way up.

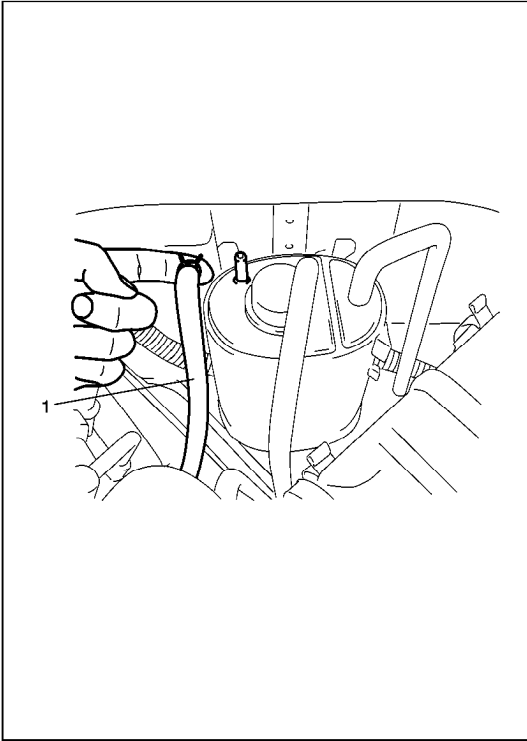

- 1) Disconnect purge hose (1) from EVAP canister.
- 2) Place finger against the end of disconnected hose and check that vacuum is not felt there when engine is cool and running at idle speed.
- 3) Connect purge hose to EVAP canister and warm up engine to normal operating temperature.
- 4) Turn ignition switch OFF.
- 5) Restart engine and run it at 2000 r/min. for 2 min. or more.
- 6) Disconnect purge hose from EVAP canister.
- 7) Also check that vacuum is felt when engine is running at 3000 r/min.

NOTE:

ECM detects a change in the purge fuel vapor concentration and sometimes stops purging for several seconds but this is nothing abnormal.

- 8) If vacuum is not felt in Step 7), run engine at idle for 8 min. or more and then repeat check in Step 7).

If check result is not satisfactory in Steps 2) and 8), check vacuum passage, hoses, EVAP canister purge valve, wire harness and ECM.

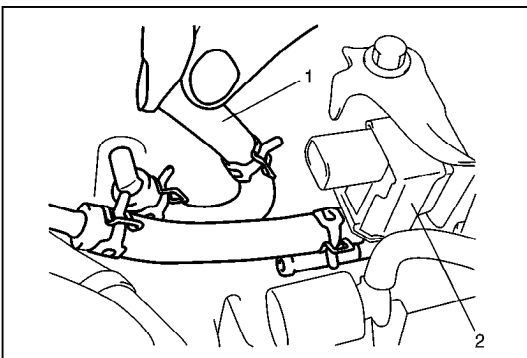

VACUUM PASSAGE INSPECTION

Start engine and run it at idle speed. Disconnect vacuum hose (1) from EVAP canister purge valve (2). With finger placed against hose disconnected, check that vacuum is applied.

If it is not applied, clean vacuum passage by blowing compressed air.

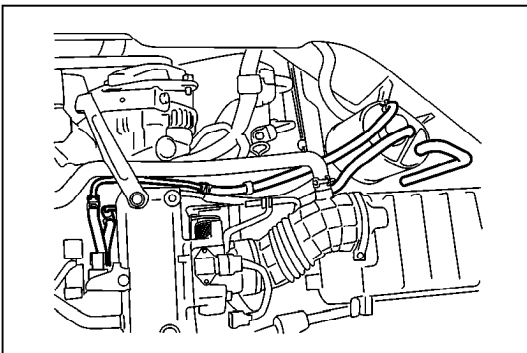

VACUUM HOSE INSPECTION

Check hoses for connection, leakage, clog and deterioration. Replace as necessary.

EVAP CANISTER PURGE VALVE INSPECTION

Check EVAP canister purge valve referring to step 1 of DTC P0443 Flow Table.

If found malfunction, replace.

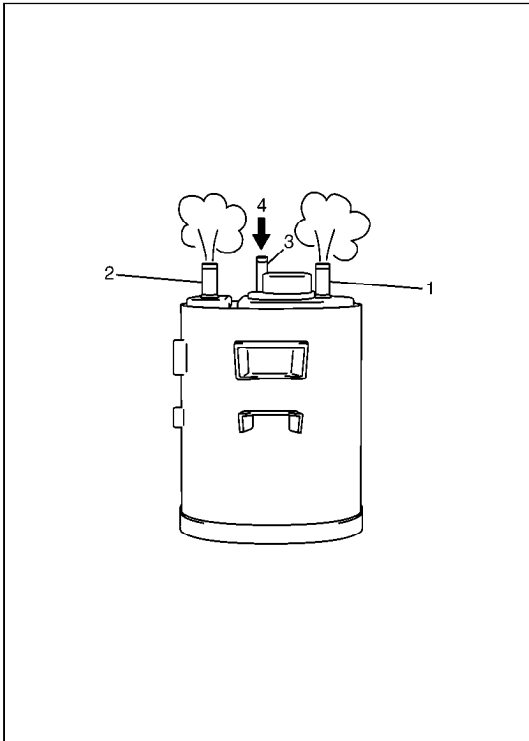

EVAP CANISTER INSPECTION

WARNING:

DO NOT SUCK nozzles on EVAP canister. Fuel vapor inside EVAP canister is harmful.

- 1) Check outside of EVAP canister visually.
- 2) Disconnect vacuum hoses from EVAP canister.
- 3) Check that there should be no restriction of flow through purge pipe (1) and air pipe (2) when air is blown (4) into tank pipe (3). If any faulty condition is found in above inspection replace.

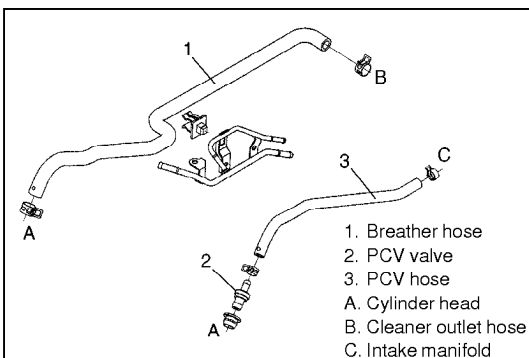

PCV SYSTEM

NOTE:

Be sure to check that there is no obstruction in PCV valve or its hoses before checking IAC duty, for obstructed PCV valve or hose hampers its accurate adjustment.

PCV HOSE INSPECTION

Check hoses for connection, leakage, clog and deterioration.

Replace as necessary.

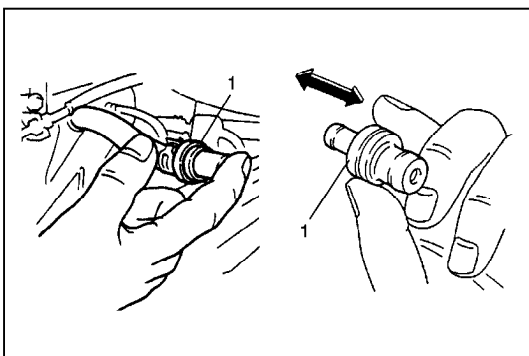

PCV VALVE INSPECTION

- 1) Disconnect PCV valve (1) from cylinder head cover and install plug to head cover hole.
- 2) Run engine at idle.
- 3) Place your finger over end of PCV valve (1) to check for vacuum. If there is no vacuum, check for clogged valve. Replace as necessary.
- 4) After checking vacuum, stop engine and remove PCV valve (1). Shake valve and listen for the rattle of check needle inside the valve. If valve does not the rattle, replace valve.
- 5) After checking, remove plug and install PCV valve (1).

SPECIAL TOOLS

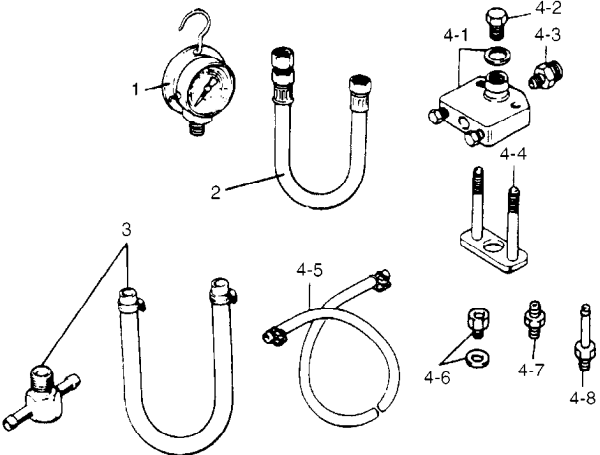
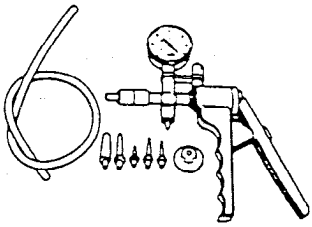
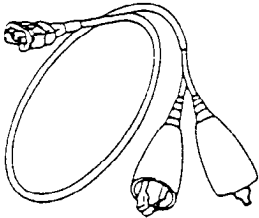
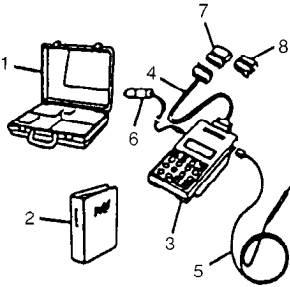
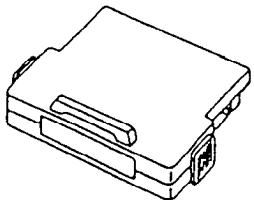
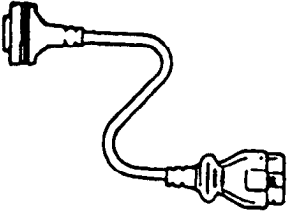
		<ol style="list-style-type: none"> 1. Pressure gauge 09912-58441 2. Pressure hose 09912-58431 3. 3-way joint & hose 09912-58490 4. Checking tool set 09912-58421 4-1. Tool body & washer 4-2. Body plug 4-3. Body attachment-1 4-4. Holder 4-5. Return hose & clamp 4-6. Body attachment-2 & washer 4-7. Hose attachment-1 4-8. Hose attachment-2
 <p>09917-47911 Vacuum pump gauge</p>	 <p>09930-88530 Injector test lead</p>	 <ol style="list-style-type: none"> 1. Storage case 2. Operator's manual 3. Tech 1A 4. DLC cable (14/26 pin, 09931-76040) 5. Test lead/probe 6. Power source cable 7. DLC cable adaptor 8. Self-test adaptor <p>09931-76011 SUZUKI scan tool (Tech 1A) kit</p>
 <p>Mass storage cartridge</p>	 <p>09931-76030 16/14 pin DLC cable</p>	

TIGHTENING TORQUE SPECIFICATIONS

Fastening parts	Tightening torque		
	N·m	kg·m	lb·ft
TP sensor mounting screw	2	0.2	1.5
IAC valve screw	3.5	0.35	2.5
ECT sensor	15	1.5	11.5
Heated oxygen sensor-1 and -2	45	4.5	32.5
CMP sensor	10	1.0	7.5
VSS	5	0.5	3.6
Delivery pipe bolts	23	2.3	17.0
CKP sensor	10	1.0	7.2
Fuel pressure regulator bolts	10	1.0	7.2

SECTION 6F

IGNITION SYSTEM

WARNING:

For vehicles equipped with Supplemental Restraint (Air Bag) System:

- Service on and around the air bag system components or wiring must be performed only by an authorized SUZUKI dealer. Refer to AIR BAG SYSTEM COMPONENTS AND WIRING LOCATION VIEW of GENERAL DESCRIPTION in air bag system section in order to confirm whether you are performing service on or near the air bag system components or wiring. Please observe all WARNINGS and SERVICE PRECAUTIONS of ON-VEHICLE SERVICE in air bag system section before performing service on or around the air bag system components or wiring. Failure to follow WARNINGS could result in unintentional activation of the system or could render the system inoperative. Either of these two conditions may result in severe injury.
- Technical service work must be started at least 90 seconds after the ignition switch is turned to the LOCK position and negative cable is disconnected from the battery. Otherwise, the system may be activated by reserve energy in the Sensing and Diagnostic Module (SDM).

CONTENTS

GENERAL DESCRIPTION	6F- 2
System Wiring Diagram	6F- 3
DIAGNOSIS	6F- 4
Diagnostic Flow Table	6F- 4
ON-VEHICLE SERVICE	6F- 6
Ignition Spark Test	6F- 6
Ignition Coil Assembly (Including Ignitor)	6F- 6
High-Tension Cord	6F- 7
Spark Plug	6F- 8
CKP Sensor	6F- 8
Ignition Timing	6F- 8
TIGHTENING TORQUE SPECIFICATION	6F-11
SPECIAL TOOLS	6F-11

GENERAL DESCRIPTION

The ignition system is an electronic (distributorless) ignition system. It consists of the parts as described below and has an electronic ignition control system.

- ECM

It detects the engine and vehicle conditions through the signals from the sensors, determines the most suitable ignition timing and time for electricity to flow to the primary coil and sends a signal to the ignitor (power unit) in the ignition coil assembly.

- Ignition coil assembly (including an ignitor)

The ignition coil assembly has a built-in ignitor which turns ON and OFF the current flow to the primary coil according to the signal from ECM. When the current flow to the primary coil is turned OFF, a high voltage is induced in the secondary coil.

- High tension cords and spark plugs

- CMP sensor (Camshaft position sensor) and CKP sensor (Crankshaft position sensor)

Using signals from these sensors, ECM identifies the specific cylinder whose piston is in the compression stroke and detects the crank angle and also controls initial ignition timing.

- TP sensor, ECT sensor, MAP sensor and other sensors/switches

Refer to Section 6E for details.

Although this ignition system does not have a distributor, it has two ignition coil assemblies (one is for No.1 and No.4 spark plugs and the other is for No.2 and No.3 spark plugs). When an ignition signal is sent from ECM to the ignitor in the ignition coil assembly for No.1 and No.4 spark plugs, a high voltage is induced in the secondary coil and cause No.1 and No.4 spark plugs to spark simultaneously. Likewise, when an ignition signal is sent to the ignitor in the other ignition coil assembly, No.2 and No.3 spark plugs spark simultaneously.

SYSTEM WIRING DIAGRAM

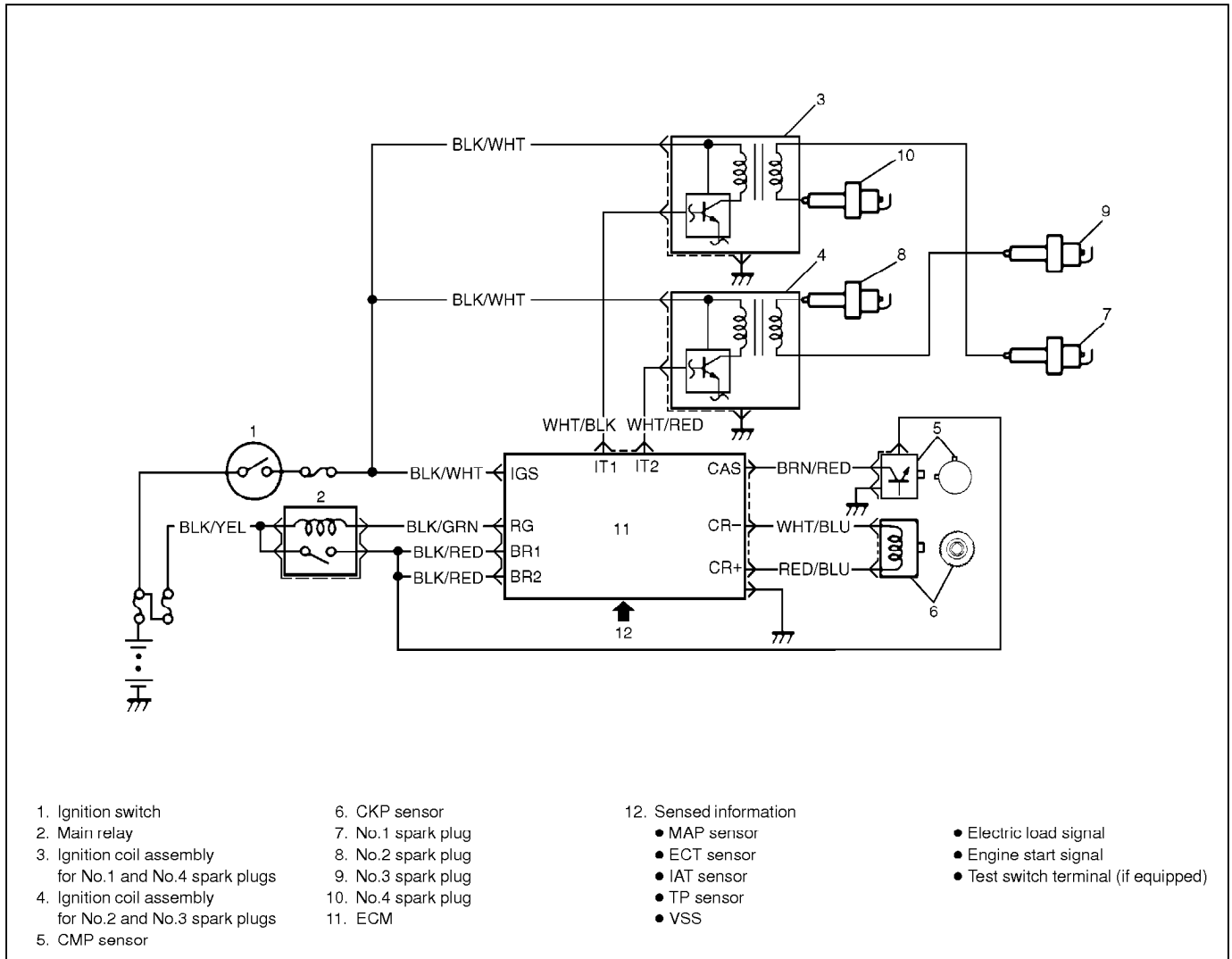

DIAGNOSIS

Condition	Possible Cause	Correction
Engine cranks, but will not start or hard to start	No spark or abnormal spark <ul style="list-style-type: none"> ● Blown fuse for ignition coil ● Loose connection or disconnection of lead wire or high-tension cord(s) ● Faulty high-tension cord(s) ● Faulty spark plug(s) ● Faulty ignition coil/ignitor ● Faulty CKP sensor or crankshaft timing belt pulley ● Faulty ECM ● Faulty CMP sensor 	Replace. Connect securely. Replace. Adjust, clean or replace. Replace ignition coil assembly. Clean, tighten or replace. Replace. Adjust or replace.
Poor fuel economy or engine performance	<ul style="list-style-type: none"> ● Incorrect ignition timing ● Faulty spark plug(s) or high-tension cord(s) ● Faulty ignition coil ● Faulty CKP sensor or crankshaft timing belt pulley ● Faulty ECM 	Check related sensors and crankshaft timing belt pulley. Adjust, clean or replace. Replace. Clean, tighten or replace. Replace.

DIAGNOSTIC FLOW TABLE

STEP	ACTION	YES	NO
1	Was "ENGINE DIAG. FLOW TABLE" performed?	Go to Step 2.	Go to "ENGINE DIAG. FLOW TABLE" in Section 6.
2	Ignition Spark Test 1) Check all spark plugs for condition and type referring to "SPARK PLUGS" in this section. 2) If OK, perform ignition spark test, referring to "IGNITION SPARK TEST" in this section. Is spark emitted from all spark plugs?	Go to Step 11.	Go to Step 3.
3	Diagnostic Trouble Code (DTC) Check Is DTC stored in ECM referring to "DTC CHECK" in Section 6?	Go to applicable DTC Diag. Flow Table in Section 6.	Go to Step 4.
4	Electrical Connection Check 1) Check ignition coil assemblies and high-tension cords for electrical connection. Are they connected securely?	Go to Step 5.	Connect securely.
5	High-Tension Cord Check 1) Check high-tension cord for resistance referring to "HIGH-TENSION CORDS" in this section. Is check result satisfactory?	Go to Step 6.	Replace high-tension cord(s).

STEP	ACTION	YES	NO
6	Ignition Coil Assembly Power Supply and Ground Circuit Check 1) Check ignition coil assembly power supply ("BLK/WHT" wire) and ground circuit ("BLK" wire) for open and short. Are circuits in good condition?	Go to Step 7.	Repair or replace.
7	Ignition Coil Assembly Check 1) Check ignition coil for resistance referring to "IGNITION COIL ASSEMBLY" in this section. Is check result satisfactory?	Go to Step 8.	Replace ignition coil assembly.
8	Crankshaft Position (CKP) Sensor Check 1) Check crankshaft position sensor referring to Step 3 and 4 of DTC P0335 (No.23) Diag. Flow Table in Section 6. Is check result satisfactory?	Go to Step 9.	Tighten CKP sensor bolt, replace CKP sensor or crankshaft timing belt pulley.
9	CMP Sensor Check 1) Check CMP sensor referring to Step 3 and 4 of DTC P0340 (No.15) Diag. Flow Table in Section 6. Is check result satisfactory?	Go to Step 10.	Tighten CMP sensor bolt, replace CMP sensor.
10	Ignition Trigger Signal Circuit Check 1) Check ignition trigger signal wires ("WHT/BLK" and "WHT/RED" wire) for open, short and poor connection. Are circuits in good condition?	Go to Step 11.	Repair or replace.
11	A known-good Ignition Coil Assembly Substitution 1) Substitute a known-good ignition coil assembly and then repeat Step 2. Is check result of Step 2 satisfactory?	Go to Step 12.	Substitute a known-good ECM and then repeat Step 2.
12	Ignition Timing Check 1) Check initial ignition timing and ignition timing advance referring to "IGNITION TIMING" in this section. Is check result satisfactory?	System is in good condition.	Check CKP sensor, crankshaft timing belt pulley (signal rotor) and input signals related to this system.

ON-VEHICLE SERVICE

IGNITION SPARK TEST

- 1) Place transmission gear shift lever in "Neutral", set parking brake, and block drive wheels.
- 2) Disconnect injector couplers and ignition coil couplers.

WARNING:

If the injector couplers are not disconnected, combustible gas will come out of the spark plug holes during this test and the vehicle can get fire .

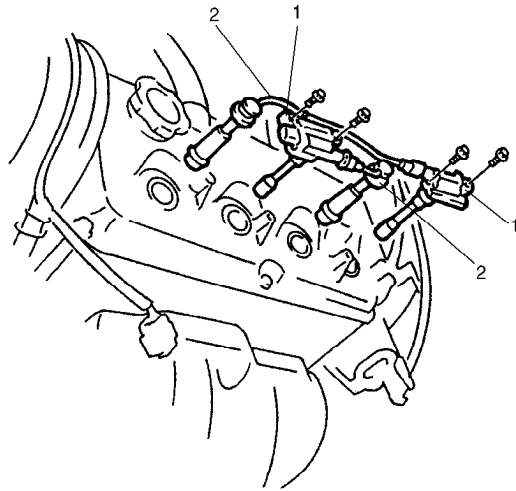

1. Ignition coil assembly
2. High-tension cord

- 3) Remove spark plugs and check them for condition and type.
- 4) If OK, connect ignition coil couplers to ignition coil and connect spark plugs to ignition coil or high-tension cord. Ground spark plugs.
- 5) Crank engine and check if all spark plugs spark normally. If the spark plugs do not spark normally (no spark or abnormal spark), inspect the related parts as described under "Diagnosis".
- 6) After checking, install spark plugs and ignition coils.
- 7) Connect injector couplers.

IGNITION COIL ASSEMBLY (INCLUDING IGNITOR)

- 1) Disconnect negative cable at battery.
- 2) Disconnect high-tension cords from ignition coil assembly.
- 3) Remove bolts and pull out ignition coil assemblies from cylinder head cover.

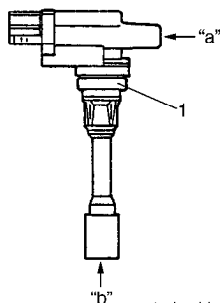

1. Ignition coil assembly

- 4) Measure secondary coil for resistance.

Secondary coil resistance ("a" – "b"):

11.1 – 15.0 kΩ at 20°C, 68°F

If resistance is out of specification, replace ignition coil assembly.

- 5) Install ignition coil assemblies to cylinder head and connect high-tension cords to ignition coil assemblies. Connect negative cable to battery.

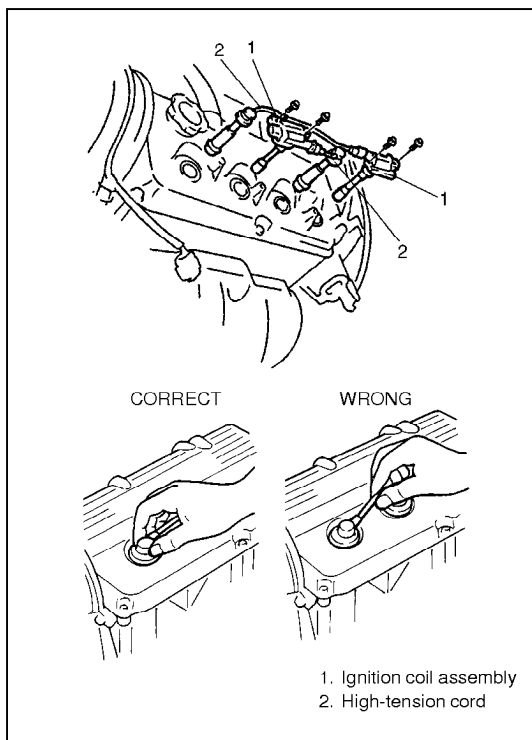

HIGH-TENSION CORD

REMOVAL

- 1) Remove high-tension cord from ignition coil assembly while gripping its cap.
- 2) Pull out high-tension cord from spark plug while gripping its cap.

CAUTION:

Pull out each connection by gripping cap portion so as not to damage their inside wire (resistive conductor).

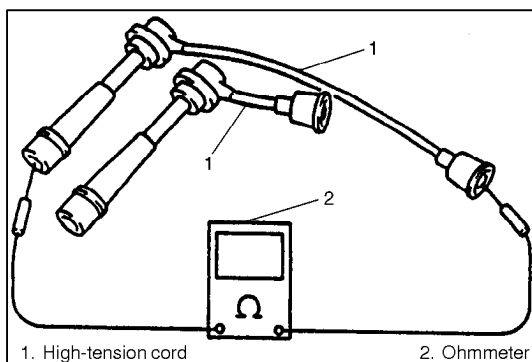

INSPECTION

Measure resistance of high-tension cord by using ohmmeter.

High-tension cord resistance: 4 – 10 k Ω /m (1.2 – 3.0 k Ω /ft)

If resistance exceeds specification, replace high-tension cord(s).

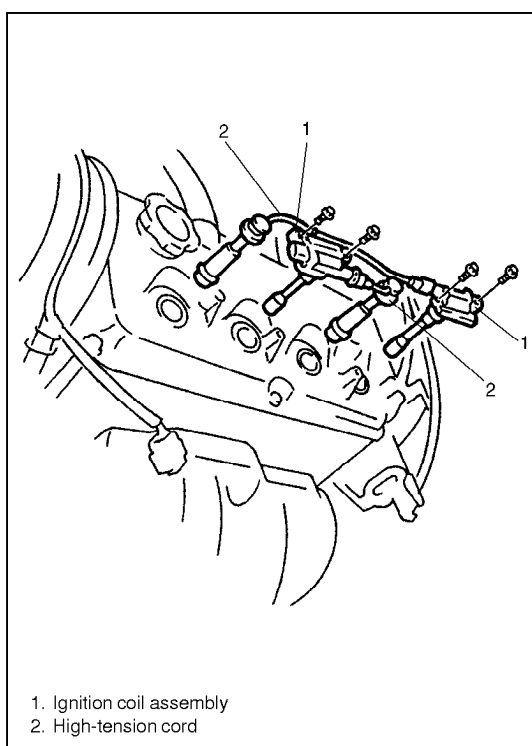

INSTALLATION

Install high-tension cord to spark plug and ignition coil assembly while gripping its cap.

CAUTION:

- Never attempt to use metal conductor high-tension cord(s) as replacing parts.
- Insert each cap portion fully when installing high-tension cords.

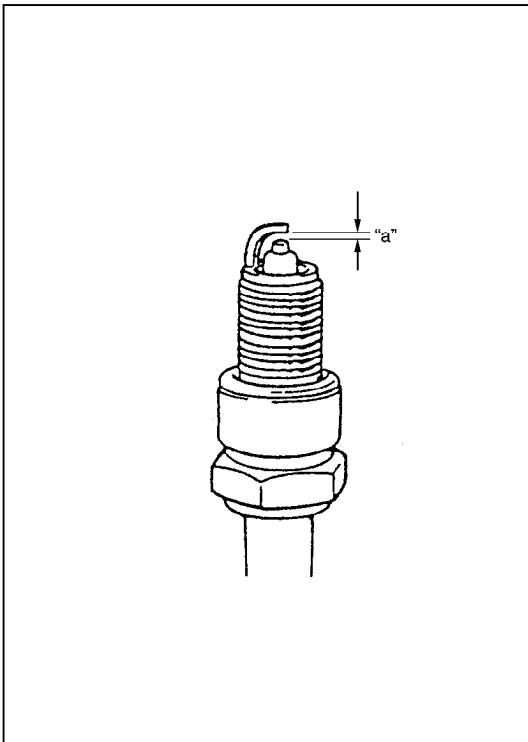

SPARK PLUG

- 1) Pull out high-tension cord by gripping its cap and then remove spark plugs.
- 2) Inspect them for:
 - Electrode wear
 - Carbon deposits
 - Insulator damage
- 3) If any abnormality is found, adjust air gap, clean with spark plug cleaner or replace them with specified new plugs.

Spark plug air gap "a" : 0.7 – 0.8 mm (0.028 – 0.031 in.)

Spark plug type: **NGK BKR6E**
 DENSO K20PR-U

- 4) Install spark plug and torque them to specification .

Tightening Torque for spark plug
28 N·m (2.8 kg-m, 20.0 lb-ft)

- 5) Install high-tension cord securely by gripping its cap.

CKP SENSOR

Refer to Section 6E for removal, inspection and installation.

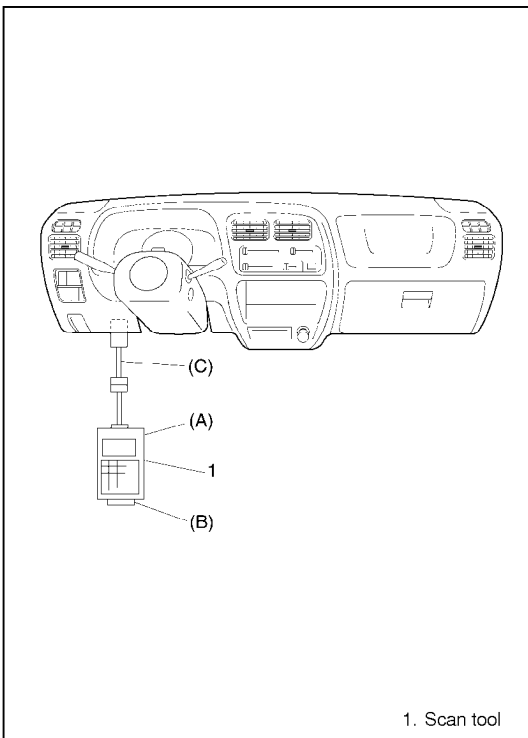

IGNITION TIMING

NOTE:

- Basically ignition timing is not adjustable. If ignition timing is out of specification, check system related parts.
- Before starting engine, shift transmission to "Neutral" and set parking brake.

INSPECTION

- 1) When using SUZUKI scan tool, connect SUZUKI scan tool to DLC with ignition switch OFF.

Special Tool

- (A): 09931-76011 (SUZUKI scan tool)**
(B): Mass storage cartridge
(C): 09931-76030 (16/14 pin DLC cable)

- 2) Start engine and warm it up to normal operating temperature.
- 3) Make sure that all of electrical loads except ignition are switched off.
- 4) Check to be sure that idle speed is within specification.
 (Refer to Section 6E)

- 5) Fix ignition timing to initial one as follows:

[Using SUZUKI scan tool]

Select "MISC TEST" mode on SUZUKI scan tool and fix ignition timing to initial one.

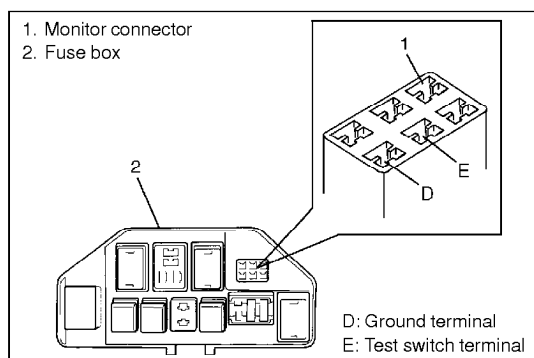

[Not using SUZUKI scan tool] (Vehicle without EGR valve)

Disconnect scan tool from DLC, and connect "D" and "E" terminals of monitor connector or "E" terminal to body ground by using service wire so that ignition timing is fixed on initial one.

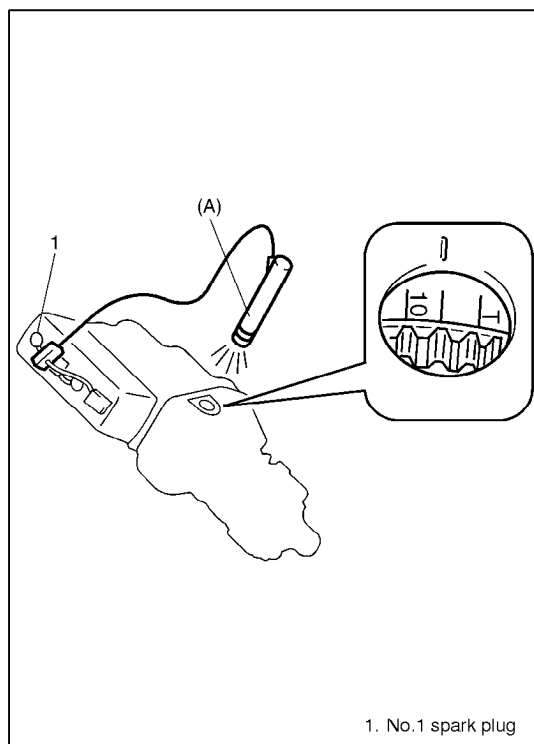

- 6) Open the engine service hole cover behind the front seats and remove the inspection hole cap on the transmission case to observe ignition timing.

- 7) Using the timing light, check that ignition timing is within specification.

Initial ignition timing (Test switch terminal grounded or fixed with SUZUKI scan tool) : $5 \pm 3^\circ$ BTDC at idle speed
Ignition order : 1-3-4-2

Special Tool
(A): 09930-76420

- 8) If ignition timing is out of specification, check the followings:
 - CKP sensor
 - Crankshaft timing belt pulley (signal rotor)
 - TP sensor
 - Test switch signal circuit (if equipped)
 - VSS

- 9) After checking Initial Ignition Timing, release ignition timing fixation by using SUZUKI scan tool or disconnect service wire from monitor connector.
- 10) With engine idling (initial ignition timing not fixed, throttle opening at closed position and car stopped), check that ignition timing fluctuates between 6° – 16° BTDC. (Constant variation within a few degrees from 6° – 16° indicates no abnormality but proves operation of electronic timing control system.) Also, check that increasing engine speed advances ignition timing. If above check results are not satisfactory, check CKP sensor, test switch terminal circuit and ECM.
- 11) Install the inspection hole cap and engine service hole cover.

TIGHTENING TORQUE SPECIFICATION

Fastening Parts	Tightening Torque		
	N·m	kg-m	lb-ft
Spark plug	28	2.8	20.0

SPECIAL TOOLS

<p>09930-76420 Timing light (Dry cell type)</p>	<ol style="list-style-type: none"> 1. Storage case 2. Operator's manual 3. Tech 1A 4. DLC cable (14/26 pin, 09931-76040) 5. Test lead/probe 6. Power source cable 7. DLC cable adapter 8. Self-test adapter <p>09931-76011 SUZUKI scan tool (Tech 1A) kit</p>	<p>Mass storage cartridge</p>
<p>09931-76030 16/14 pin DLC cable</p>		

SECTION 6H

CHARGING SYSTEM

WARNING:

For vehicles equipped with Supplemental Restraint (Air Bag) System:

- Service on and around the air bag system components or wiring must be performed only by an authorized SUZUKI dealer. Refer to AIR BAG SYSTEM COMPONENTS AND WIRING LOCATION VIEW of GENERAL DESCRIPTION in air bag system section in order to confirm whether you are performing service on or near the air bag system components or wiring. Please observe all WARNINGS and SERVICE PRECAUTIONS of ON-VEHICLE SERVICE in air bag system section before performing service on or around the air bag system components or wiring. Failure to follow WARNINGS could result in unintentional activation of the system or could render the system inoperative. Either of these two conditions may result in severe injury.
- Technical service work must be started at least 90 seconds after the ignition switch is turned to the LOCK position and negative cable is disconnected from the battery. Otherwise, the system may be activated by reserve energy in the Sensing and Diagnostic Module (SDM).

NOTE:

For the descriptions (items) not found in this section, refer to the same section of the Service Manual mentioned in the FOREWORD of this manual.

CONTENTS

GENERAL DESCRIPTION	6H- 2
Generator	6H- 2
DIAGNOSIS	6H- 3
Generator	6H- 3
UNIT REPAIR OVERHAUL	6H- 5
Disassembly and Reassembly	6H- 5
Inspection	6H- 6
SPECIFICATIONS	6H- 7
Generator	6H- 7

GENERAL DESCRIPTION

GENERATOR

[70 A type]

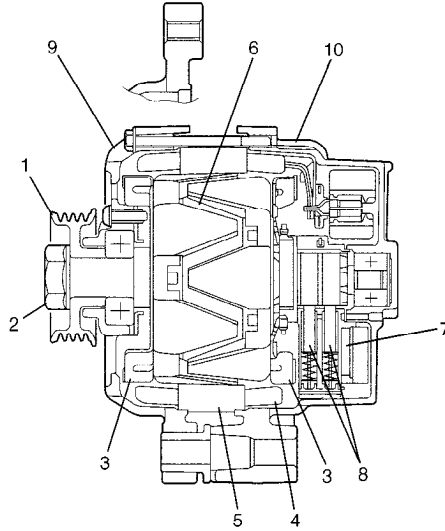

- 1. Pulley
- 2. Pulley nut
- 3. Rotor fan
- 4. Stator coil
- 5. Stator core
- 6. Field coil
- 7. Regulator
- 8. Brush
- 9. Front housing
- 10. Rear housing

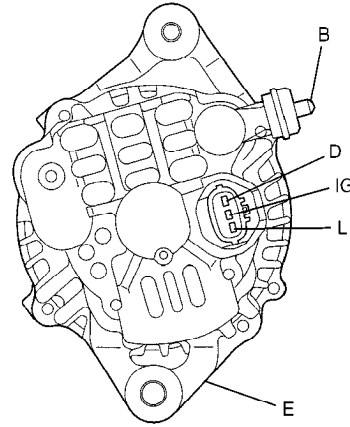

- B : Generator output (Battery terminal)
- D : Dummy terminal
- E : Ground
- IG : Ignition terminal
- L : Lamp terminal

DIAGNOSIS

GENERATOR

UNDERCHARGED BATTERY

This condition, as evidenced by slow cranking or indicator clear with red dot can be caused by one or more of the following conditions even though indicator lamp may be operating normal.

Following procedure also applies to cars with voltmeter and ammeter.

- 1) Make sure that undercharged condition has not been caused by accessories left on for extended period of time.
- 2) Check drive belt for proper tension.
- 3) If battery defect is suspected, refer to Battery section.
- 4) Inspect wiring for defects. Check all connections for tightness and cleanliness, battery cable connections at battery, starting motor and ignition ground cable.
- 5) Connect voltmeter and ammeter as shown in left figure.

Voltmeter

Set between generator B terminal and ground.

Ammeter

Set between generator B terminal and battery (+) terminal.

NOTE:

Use fully charged battery.

- 6) Measure current and voltage.

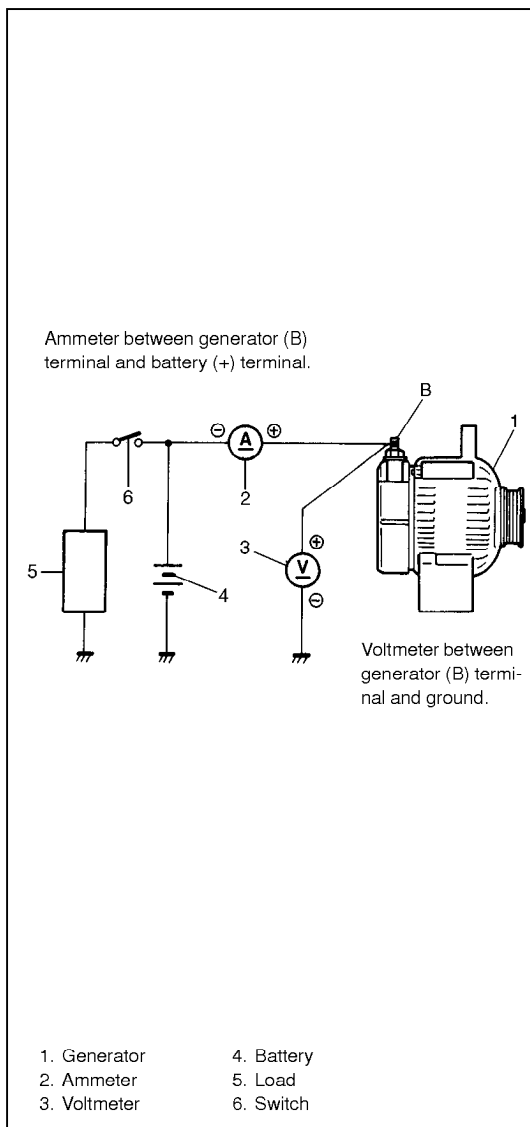

No-load Check

- 1) Run engine from idling up to 2,000 rpm and read meters.

NOTE:

Turn off switches of all accessories (wiper, heater etc.).

Standard current: 10 A maximum

Standard voltage: 14.4 – 15.0 V (at 20 °C, 68 °F)

NOTE:

Consideration should be taken that voltage will differ somewhat with regulator case temperature as shown in left figure.

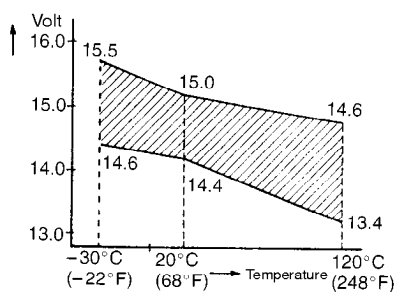

Higher Voltage

If voltage is higher than standard value, check ground of brushes.
If brushes are not grounded, replace IC regulator.

Lower Voltage

If voltage is below or in standard value, increase engine speed up to 2000 – 2500 rpm soon after starting engine with all electrical loads on, and read maximum value on ammeter immediately.

If current is less than 49 A, repair or replace generator.

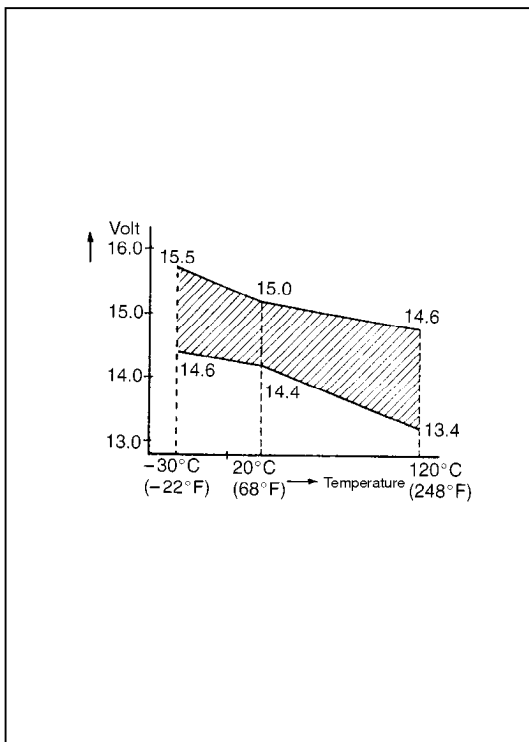
**OVERCHARGED BATTERY**

- 1) To determine battery condition, refer to Battery section.
- 2) If obvious overcharge condition exists as evidenced by excessive spewing of electrolyte, measure generator B terminal voltage at engine 2000 rpm.
- 3) If measured voltage is higher than upper limit value, proceed to disassembly section of generator service.
- 4) Check ground of brushes. If brushes are not grounded, replace IC regulator. Then check field coil for grounds and shorts, referring to "INSPECTION" section.

UNIT REPAIR OVERHAUL

DISASSEMBLY AND REASSEMBLY

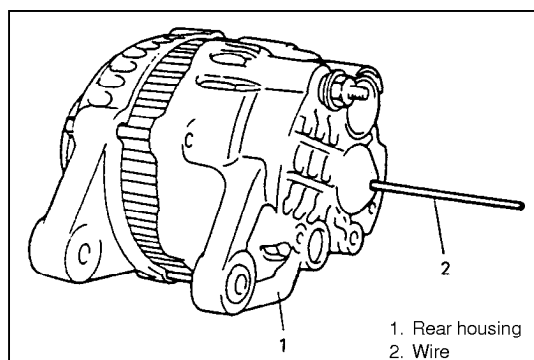
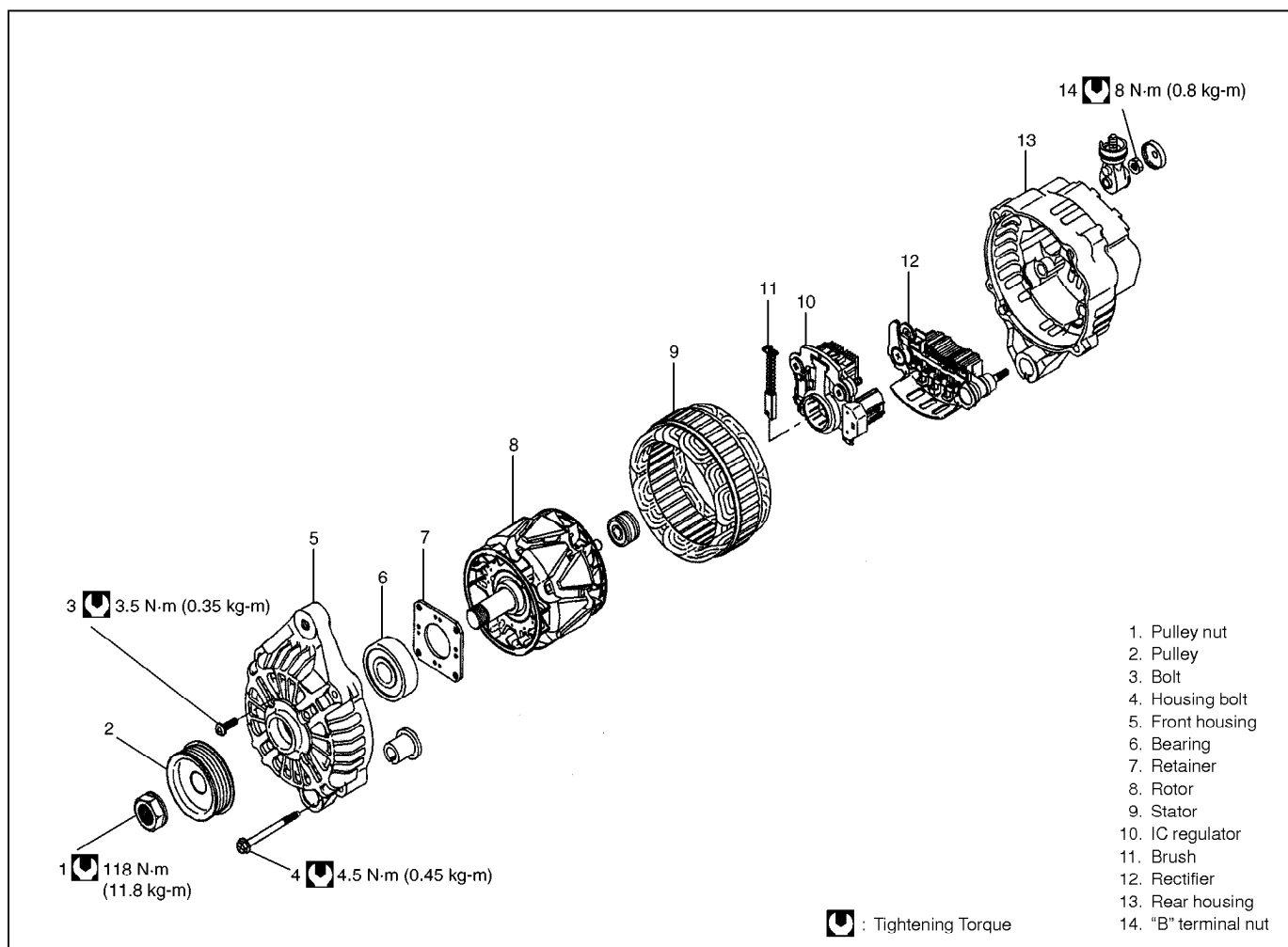

Assemble noting the following instruction.

- Push brushes into brush holder, then support brushes by inserting appropriate wire from hole of rear housing.

NOTE:

- After installing rotor, remove wire.
- Check to make sure that match marks on front and rear housing are aligned.
- Do not apply grease to rear (rotor) bearing. Remove oil completely if found in bearing box of rear housing.
- After assembling generator, make sure that rotor turns smoothly.

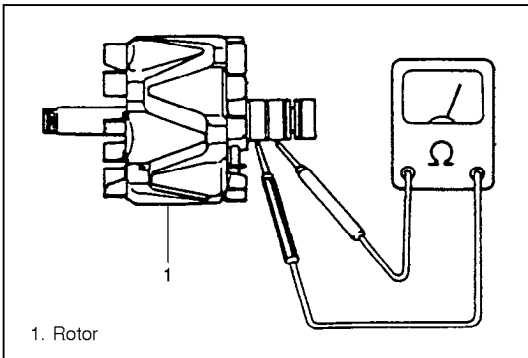

INSPECTION

Rotor

- 1) Using ohmmeter, check for continuity between slip rings of rotor. If there is no continuity, replace rotor.

Standard resistance: 2.3 – 2.7 Ω

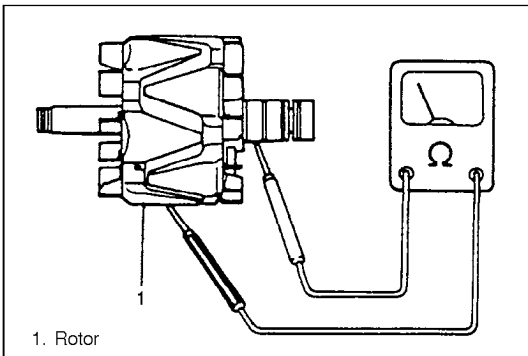

- 2) Using ohmmeter, check that there is no continuity between slip ring and rotor core. If there is continuity, replace rotor.
- 3) Check slip rings for roughness or scoring. If rough or scored, replace rotor.

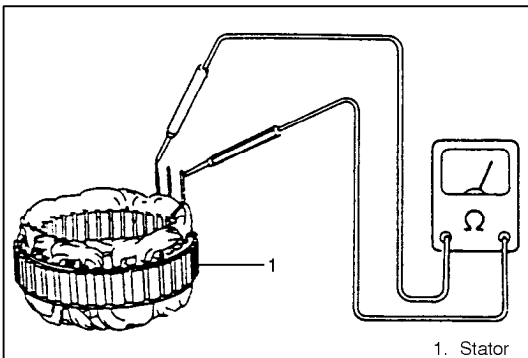

Stator

- 1) Using ohmmeter, check all leads for continuity. If there is no continuity, replace stator.

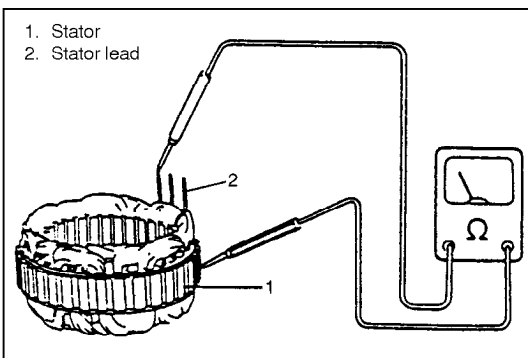

- 2) Using ohmmeter, check that there is no continuity between coil leads and stator core. If there is continuity, replace stator.

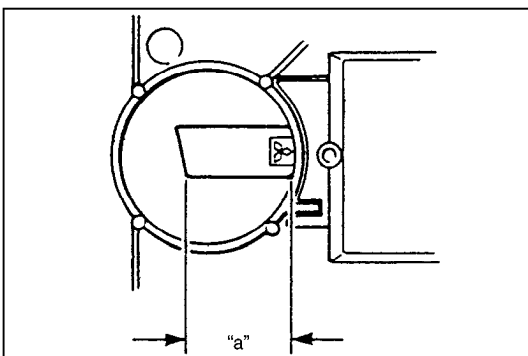

Brush and brush holder

Check each brush for wear by measuring its length. If brush is found worn down to service limit, replace brush.

Brush length "a"

Standard: 16 mm (0.63 in.)

Service limit: 2 mm (0.08 in.)

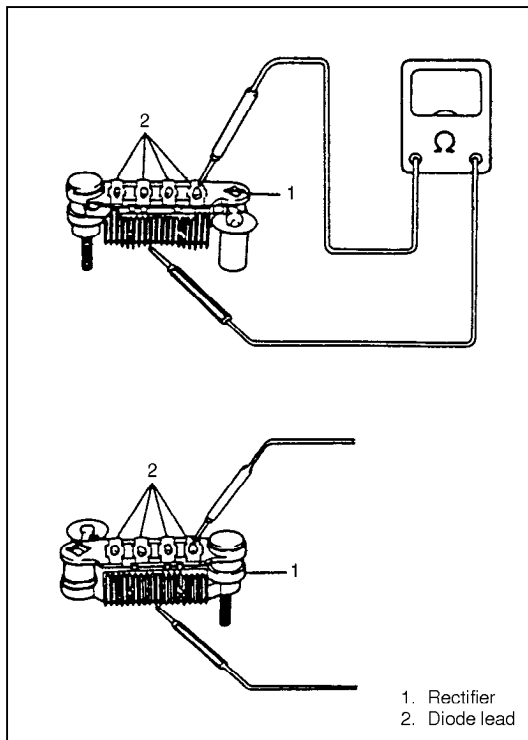

Rectifier

- 1) Using ohmmeter, check continuity between each of upper and lower rectifier heatsinks and each diode lead. Check both directions by reversing probes of ohmmeter and there should be only one-way continuity in each case. If check result is not satisfactory, replace rectifier.
- 2) In the same manner as described in above step 1), check that there is only one-way continuity between both leads of diode trio.

SPECIFICATIONS

GENERATOR

Type	70 A Type
Rated voltage	12 V
Nominal output	70 A
Permissible max. speed	18,000 r/min.
No-load speed	1,500 r/min. (rpm)
Setting voltage	14.4 to 15.0 V
Permissible ambient temperature	- 30 to 90°C (- 22 to 194°F)
Polarity	Negative ground
Rotation	Clockwise viewed from pulley side

SECTION 6K

EXHAUST SYSTEM

NOTE:

- For the descriptions (items) not found in this section, refer to the same section of the Service Manual mentioned in the FOREWORD of this manual.
- Whether following parts are used in the particular vehicle or not depends on specification.

ON-VEHICLE SERVICE

CAUTION:

Be sure to use UNLEADED FUEL for the catalytic converter equipped vehicle. Use of LEADED FUEL will affect performance of the catalytic converter adversely to a great extent.

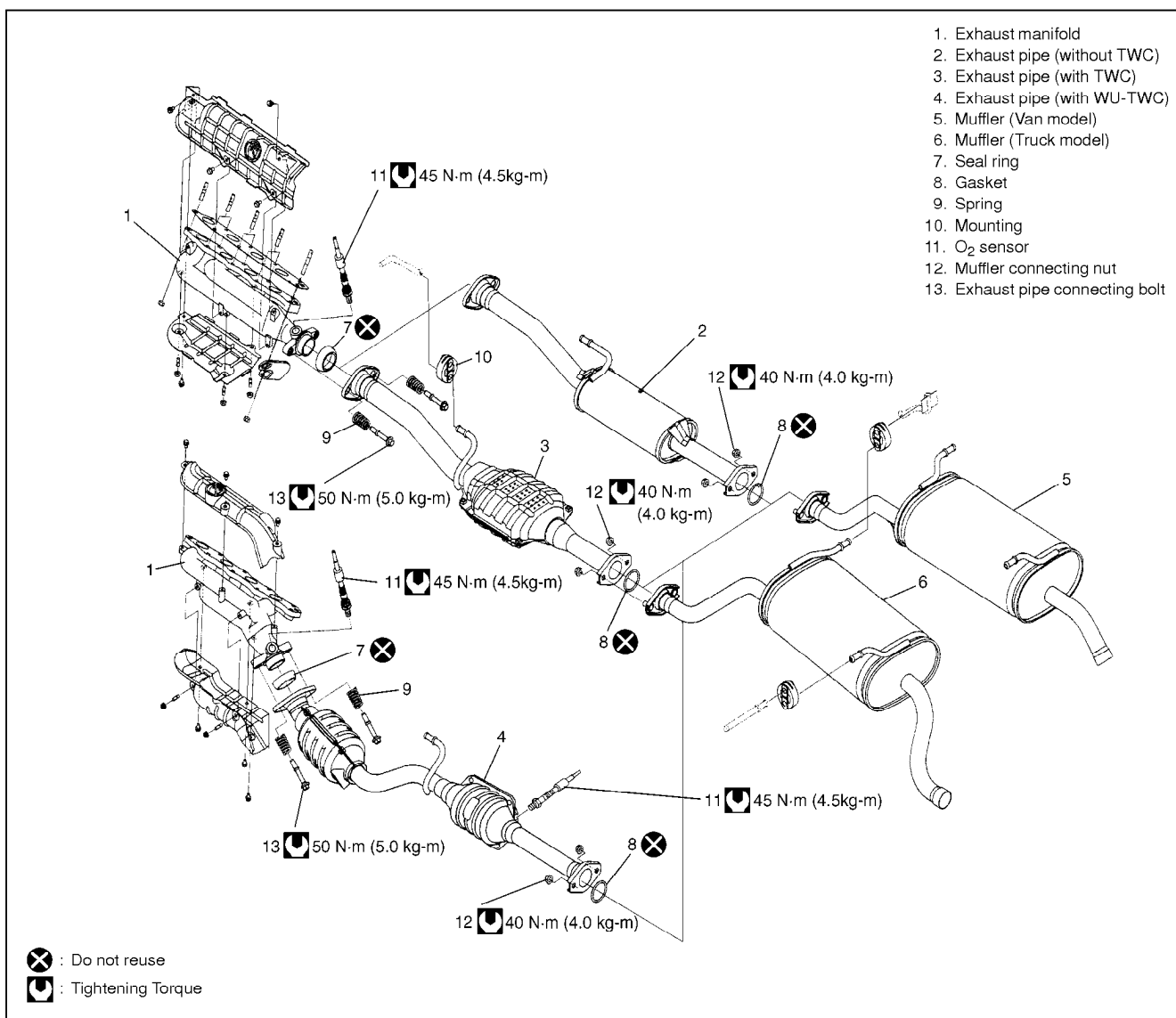

SECTION 8

BODY ELECTRICAL SYSTEM

WARNING:

For vehicles equipped with Supplemental Restraint (Air Bag) System:

- Service on and around the air bag system components or wiring must be performed only by an authorized SUZUKI dealer. Refer to “Air Bag System Components and Wiring Location View” under “General Description” in air bag system section in order to confirm whether you are performing service on or near the air bag system components or wiring. Please observe all WARNINGS and “Service Precautions” under “On-Vehicle Service” in air bag system section before performing service on or around the air bag system components or wiring. Failure to follow WARNINGS could result in unintentional activation of the system or could render the system inoperative. Either of these two conditions may result in severe injury.
- Technical service work must be started at least 90 seconds after the ignition switch is turned to the “LOCK” position and the negative cable is disconnected from the battery. Otherwise, the system may be activated by reserve energy in the Sensing and Diagnostic Module (SDM).

NOTE:

For the descriptions (items) not found in this section, refer to the same section of the Service Manual mentioned in the Foreword of this manual.

CONTENTS

ON-VEHICLE SERVICE	8-2
Headlight	8-2
Headlight Switch	8-2
Turn Signal and Hazard Warning Lights	8-3
Turn Signal Light Switch	8-3
Windshield Wiper and Washer	8-4
Components	8-4
Front Wiper and Washer	8-4
Rear Wiper (If Equipped)	8-4
Front Wiper and Washer Switch	8-5
Intermittent Wiper Relay Circuit (If Equipped)	8-6
Washer Linked Operation	8-6
Washer Tank and Washer Pump	8-7
Rear Wiper and Washer Switch (If Equipped)	8-7
Rear Washer Pump (If Equipped)	8-8
Rear Wiper Motor (If Equipped)	8-8

ON-VEHICLE SERVICE

HEADLIGHT

HEADLIGHT SWITCH

REMOVAL AND INSTALLATION

Refer to COMBINATION SWITCH/CONTACT COIL AND COMBINATION SWITCH ASSEMBLY in Section 3C.

INSPECTION

Use an ohmmeter to check the continuity at each switch position shown below. If any continuity is not obtained, replace combination switch (1).

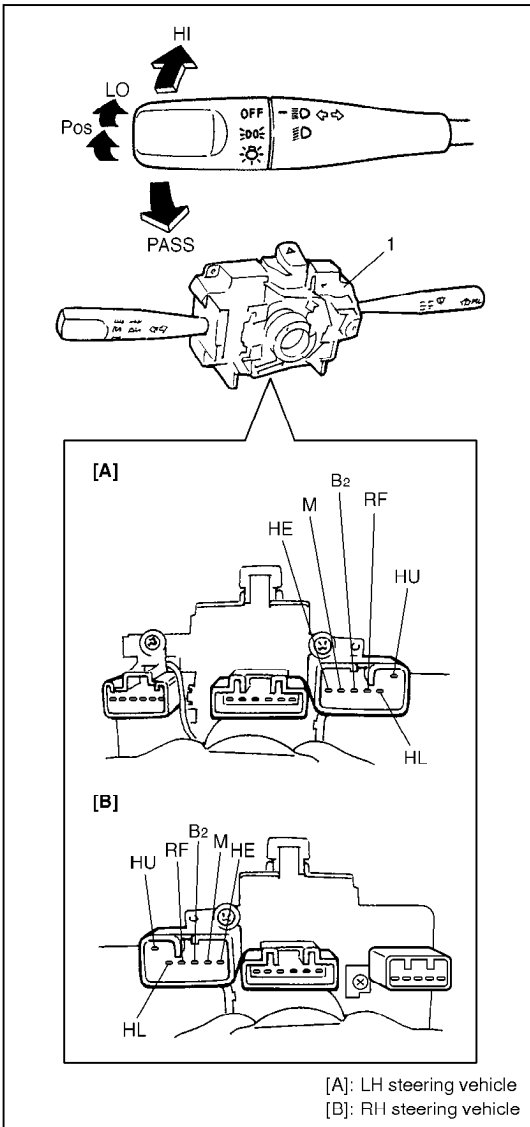

Switch Position		Terminal					
		HE	HU	HL	RF	B ₂	M
OFF	passing	○—○					
	⊖⊕					○—○	
☀	Low Beam	○—○		○—○		○—○	○—○
	passing	○—○	○—○		○—○	○—○	○—○
	High Beam	○—○	○—○		○—○	○—○	○—○

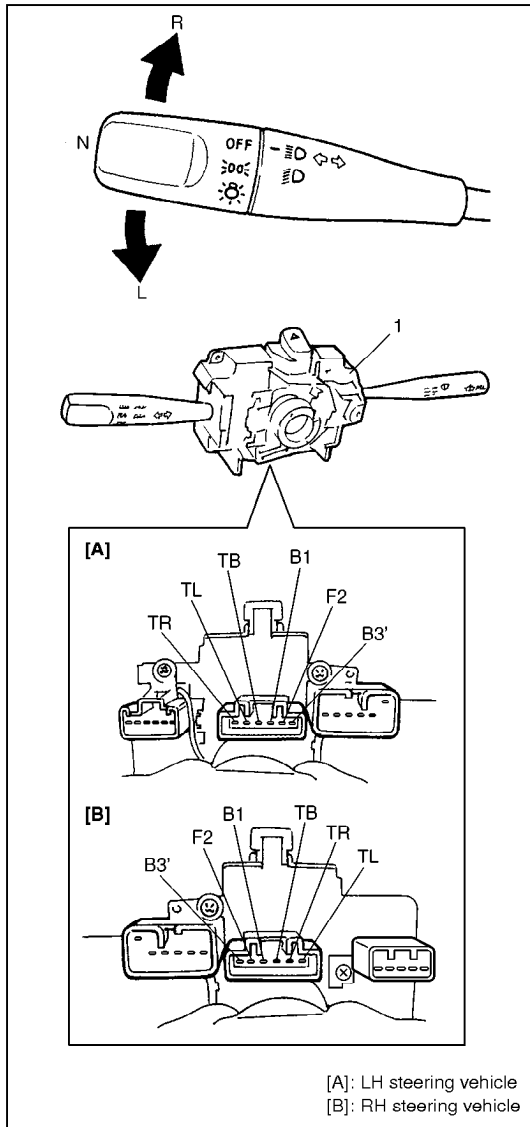

[A]: LH steering vehicle
[B]: RH steering vehicle

TURN SIGNAL AND HAZARD WARNING LIGHTS

TURN SIGNAL LIGHT SWITCH REMOVAL AND INSTALLATION

Refer to COMBINATION SWITCH/CONTACT COIL AND COMBINATION SWITCH ASSEMBLY in Section 3C.

INSPECTION

Use an ohmmeter to check the continuity at each switch position shown below. If any continuity is not obtained, replace combination switch (1).

		Terminal						
		TL	TB	TR	B3'	B1	F2	
Hazard SW	Turn Signal SW	L	○	○				
		N				○	○	
		R		○	○			
ON		○	○	○		○	○	

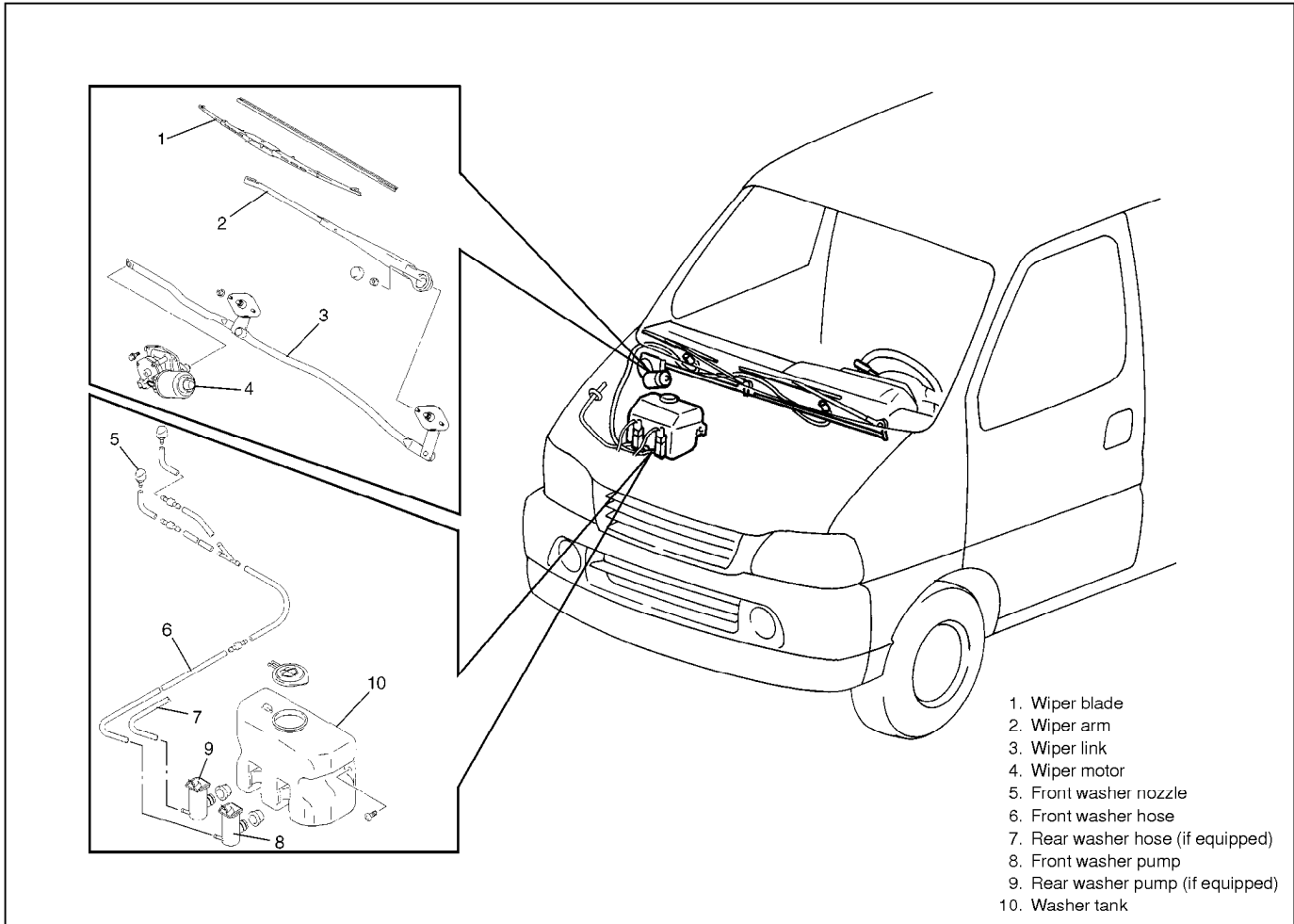
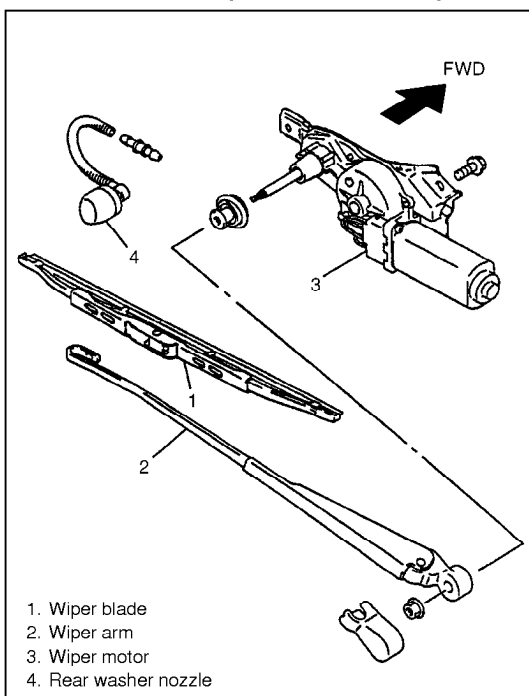
WINDSHIELD WIPER AND WASHER**COMPONENTS****FRONT WIPER AND WASHER****REAR WIPER (IF EQUIPPED)**

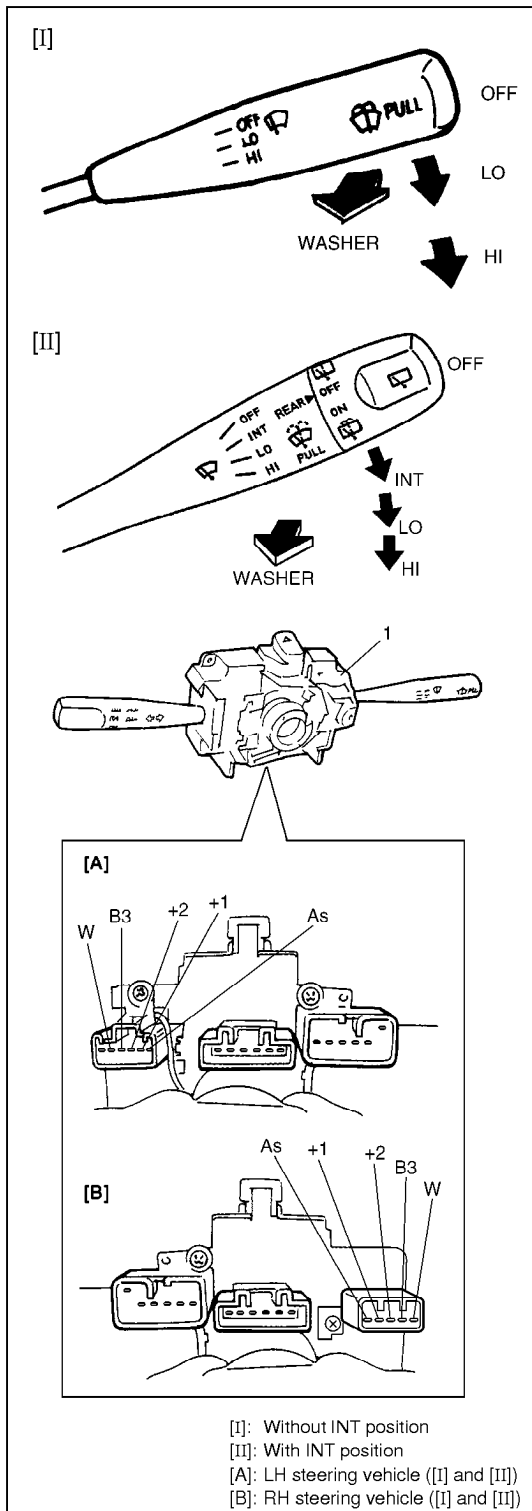

FRONT WIPER AND WASHER SWITCH REMOVAL AND INSTALLATION

Refer to "COMBINATION SWITCH/CONTACT COIL AND COMBINATION SWITCH ASSEMBLY" in Section 3C.

INSPECTION

Use a circuit tester to check the continuity at each switch position as shown below. If any continuity is not obtain, replace combination switch (1).

Terminal	B3	+2	+1	As
Wiper SW				
OFF			○	○
INT (if equipped)			○	○
LO	○		○	
HI	○	○		

Terminal	B3	W
Washer SW		
OFF		
ON	○	○

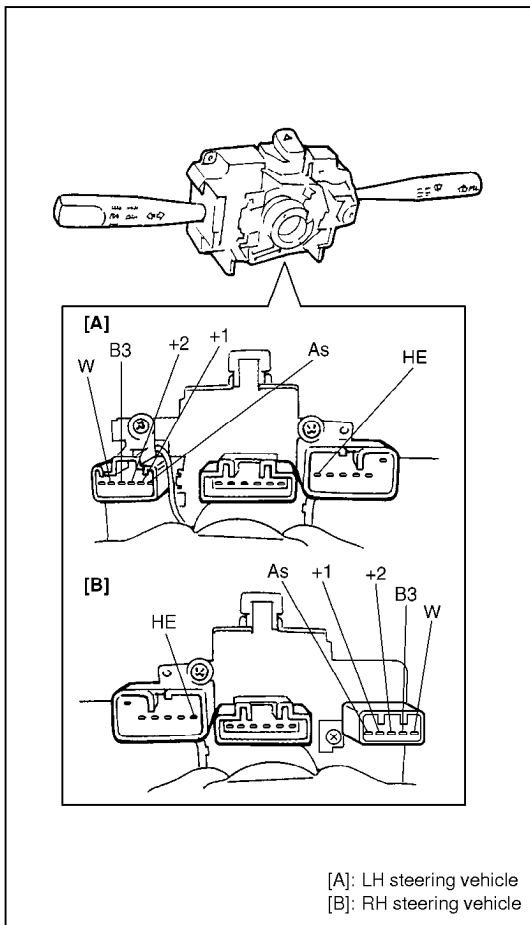

INTERMITTENT WIPER RELAY CIRCUIT (IF EQUIPPED)

INSPECTION

- 1) Disconnect negative cable (–) at battery.
- 2) Disconnect combination switch lead wire coupler.
- 3) Turn the front wiper switch to INT position.
- 4) Connect battery positive terminal (+) to terminal “B3” and battery negative terminal (–) to terminal “HE”.
- 5) Connect voltmeter positive lead to terminal “+1” and negative lead to terminal “HE”. Check that the voltmeter indicates the battery voltage (10 – 14 V).
- 6) Connect terminal “As” and terminal “B3” by a jumper wire. Then connect terminal “B3” end to terminal “HE”. Observe the voltmeter voltage drops to 0 V right after connection the jumper wire from terminal “B3” to “HE”. Then the voltage rises to battery voltage (10 – 14 V) within the time shown below.

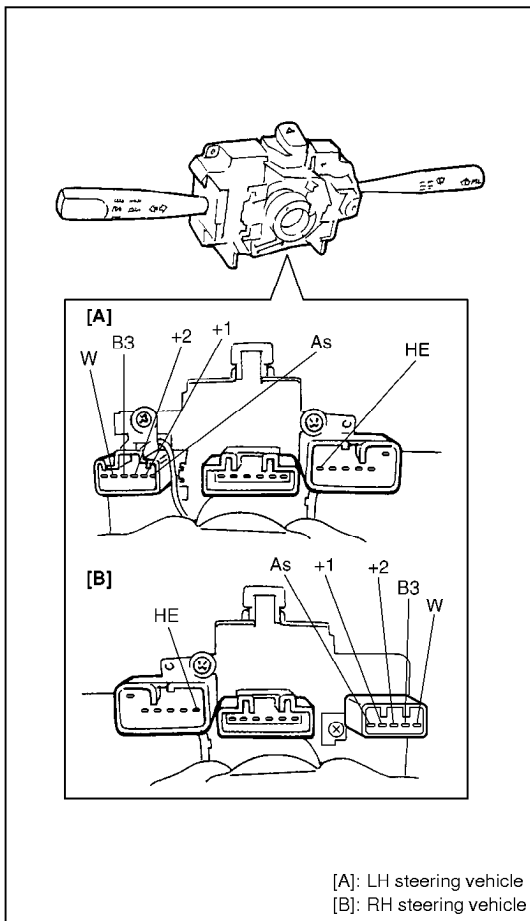
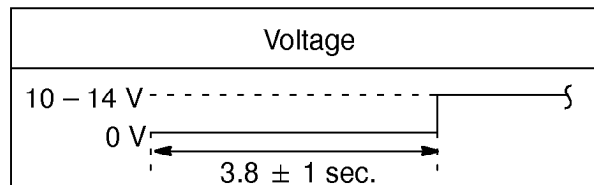

WASHER LINKED OPERATION INSPECTION

- 1) Disconnect negative cable (–) at battery.
- 2) Disconnect combination switch lead wire coupler.
- 3) Make sure that front wiper switch is at OFF position.
- 4) Connect battery positive terminal (+) to terminal “B3” and battery negative terminal (–) to terminal “HE”.
- 5) Connect voltmeter positive lead to terminal “+1” and negative lead to terminal “HE”.
- 6) Push washer switch check that voltage changes as shown below.

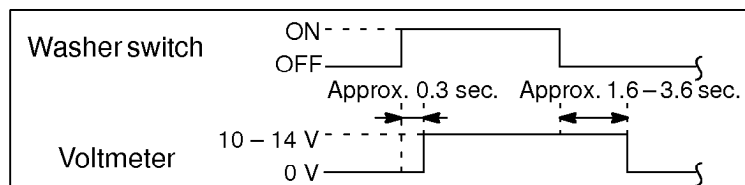

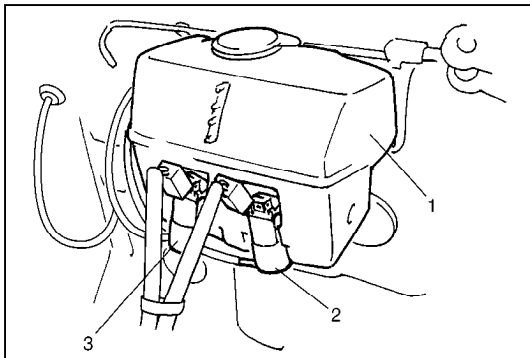

WASHER TANK AND WASHER PUMP REMOVAL

- 1) Disconnect battery (-) cable.
- 2) Remove washer tank (1) fitting screws.
- 3) Disconnect pump lead wire coupler and hose.
- 4) Remove washer tank (1).
- 5) Remove front washer pump (2) and rear washer pump (3) (if equipped).

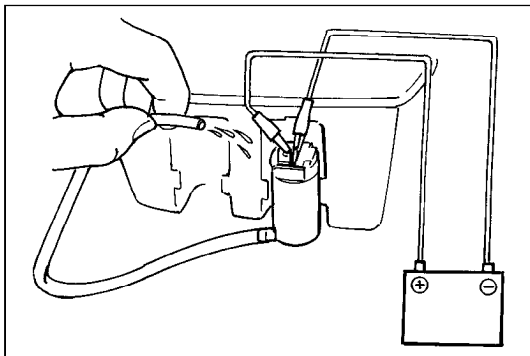

INSPECTION

Connect battery (+) and (-) terminals to pump (+) and (-) terminals respectively to check pumping rate.
 Check for washer pump.
 Reference pumping Rate: more than 1.0 l/min
 (2.1 US pt./min, 1.76 Imp pt./min)

INSTALLATION

Reverse removal procedure for installation.

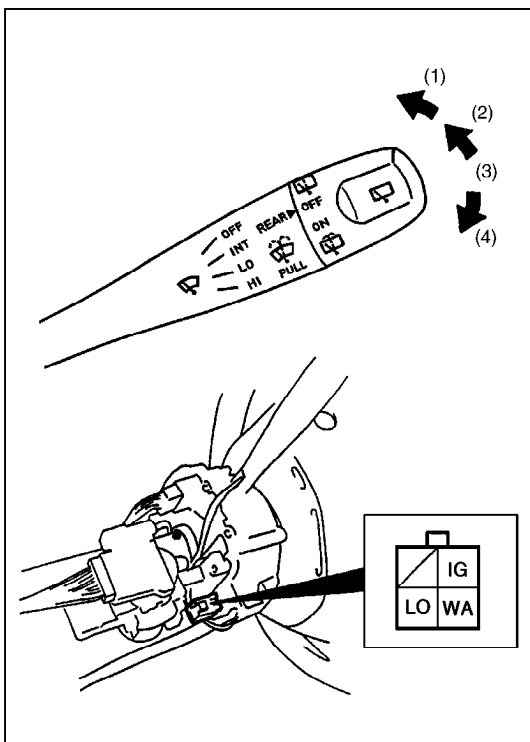

REAR WIPER AND WASHER SWITCH (IF EQUIPPED)

INSPECTION

Type 1: In Combination Switch

Check for continuity between terminals at each switch position as shown below. If check result is not as specified, replace.

Position \ Terminal	IG	LO	WA
(1) WIPER and WASHER ON	○	○	○
(2) WIPER ON	○	○	
(3) OFF			
(4) WASHER and WIPER ON	○	○	○

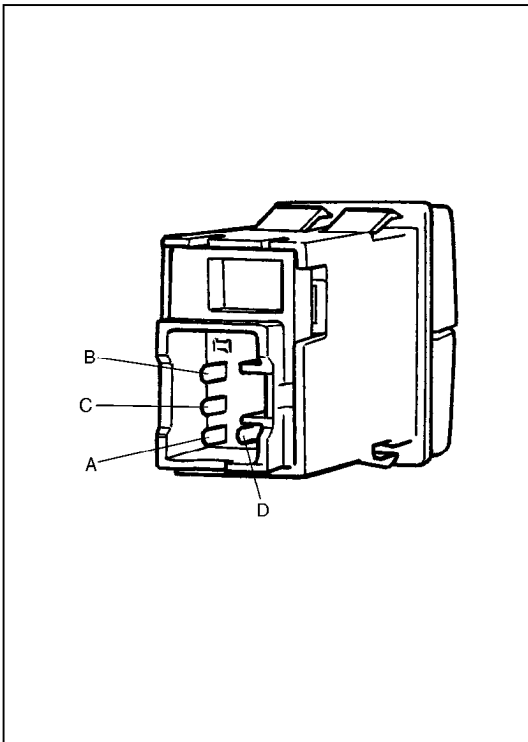

Type 2: On Instrument Panel

Check for continuity between terminals at each switch position as shown below. If check result is not as specified, replace.

Wiper & Washer SW		Terminal	A	B	C	D
		Wiper SW				
OFF	OFF			○—○		
	ON	○—○	○—○			
Washer ON	OFF	○—○				○
	ON	○—○	○—○			○
ON	OFF	○—○	○—○			○
	ON	○—○	○—○	○—○		○

REAR WASHER PUMP (IF EQUIPPED)

Refer to "WASHER TANK AND WASHER PUMP" in this section for inspection procedure.

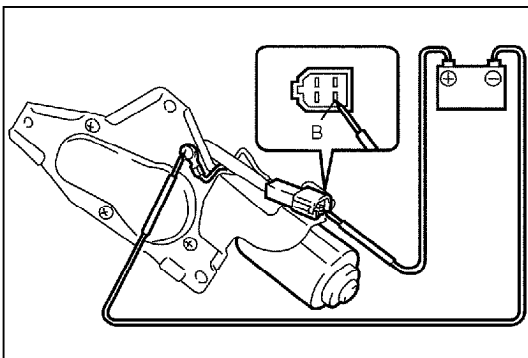

REAR WIPER MOTOR (IF EQUIPPED)

INSPECTION

Wiper Motor

As shown left, use a 12V battery to connect its (+) and (-) terminals to terminal "B" and wiper bracket (wiper ground) respectively. Then motor should rotate at 35 to 45 rpm.

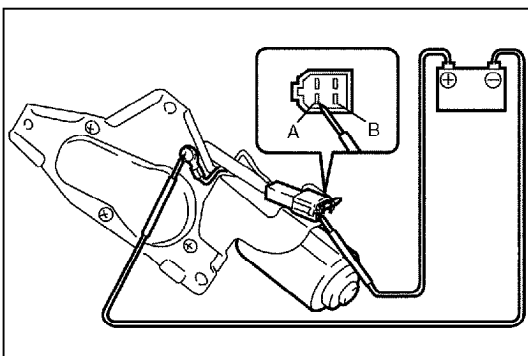

Automatic Stop Operation

- 1) First, connect battery (+) terminal to terminal "B" and battery (-) terminal to wiper bracket (wiper ground) and let the motor turn.
- 2) Then disconnect terminal "B" from battery and let the motor stop.
- 3) Connect terminal "A" to battery (+) terminal. Observe the wiper motor turns once again, then stops at a given position.
- 4) Repeat these steps several times, and inspect if the motor stops at the given position every time.

SECTION 8G

IMMOBILIZER CONTROL SYSTEM (IF EQUIPPED)

WARNING:

For vehicles equipped with Supplemental Restraint (Air Bag) System

- Service on and around the air bag system components or wiring must be performed only by an authorized SUZUKI dealer. Refer to “Air Bag System Components and Wiring Location View” under “General Description” in air bag system section in order to confirm whether you are performing service on or near the air bag system components or wiring. Please observe all WARNINGS and “Service Precautions” under “On-Vehicle Service” in air bag system section before performing service on or around the air bag system components or wiring. Failure to follow WARNINGS could result in unintentional activation of the system or could render the system inoperative. Either of these two conditions may result in severe injury.
- Technical service work must be started at least 90 seconds after the ignition switch is turned to the “LOCK” position and the negative cable is disconnected from the battery. Otherwise, the system may be activated by reserve energy in the Sensing and Diagnostic Module (SDM).

CONTENTS

GENERAL DESCRIPTION	8G- 2	DTC84 (P1620) ECM/Immobilizer Control Module Code Not Registered	8G-16
DIAGNOSIS	8G- 6	DTC 82 (P1622) Fault in ECM	8G-16
Precautions in Diagnosing Troubles	8G- 6	DTC22 Ignition Switch Circuit Open/Short	8G-17
Diagnostic Flow Table	8G- 7	DTC23 No ECM/Immobilizer Control Module Code Transmitted from ECM or DLC Circuit Opened/Shorted	8G-18
Diagnostic Trouble Code Check (Immobilizer Control Module)	8G- 8	DTC83 (P1621) No ECM/Immobilizer Control Module Code Transmitted from Immobilizer Control Module or DLC Circuit Opened/Shorted	8G-18
Diagnostic Trouble Code Check (ECM)	8G- 9	Inspection of ECM, Immobilizer Control Module and its Circuit	8G-20
Diagnostic Trouble Code Table	8G-11	ON-VEHICLE SERVICE	8G-22
TABLE A DTC is not Output from Diagnostic Output Terminal	8G-12	Precautions in Handling Immobilizer Control System	8G-22
DTC 11 Transponder Code Not Matched .	8G-13	Immobilizer Control Module	8G-23
DTC 31 Transponder Code Not Registered	8G-13	Coil Antenna	8G-23
DTC 12 Fault in Immobilizer Control Module	8G-13	HOW TO REGISTER IGNITION KEY	8G-24
DTC 13 No Transponder Code Transmitted or Coil Antenna Opened/Shorted	8G-14	PROCEDURE AFTER IMMOBILIZER CONTROL MODULE REPLACEMENT	8G-26
DTC21 ECM/Immobilizer Control Module Code Not Matched (Immobilizer Control Module Side)	8G-16		
DTC81 (P1623) ECM/Immobilizer Control Module Code Not Matched (ECM Side) .	8G-16		

GENERAL DESCRIPTION

The immobilizer control system designed to prevent vehicle burglar consists of following components.

- Engine control module (ECM)
- Immobilizer control module
- Ignition key with built-in transponder
- Coil antenna

Operation of this system is as follows.

- (1) Each ignition key has its own code (Transponder code) stored in memory. When the ignition switch is turned ON, Immobilizer Control Module tries to read the Transponder code through the coil antenna installed to the steering lock assembly.
- (2) Immobilizer Control Module compares the Transponder code read in (1) and that registered in Immobilizer Control Module and checks if they match.
- (3) When it is confirmed that two Transponder codes match each other as described above, Immobilizer Control Module and ECM check if ECM/Immobilizer Control Module codes registered in them respectively match.
- (4) Only when it is confirmed that ECM/Immobilizer Control Module codes match, the engine starts running. If Transponder codes in Step (2) or ECM/Immobilizer Control Module codes in Step (3) do not match, ECM will stop operation of the injector and ignition of spark plug.

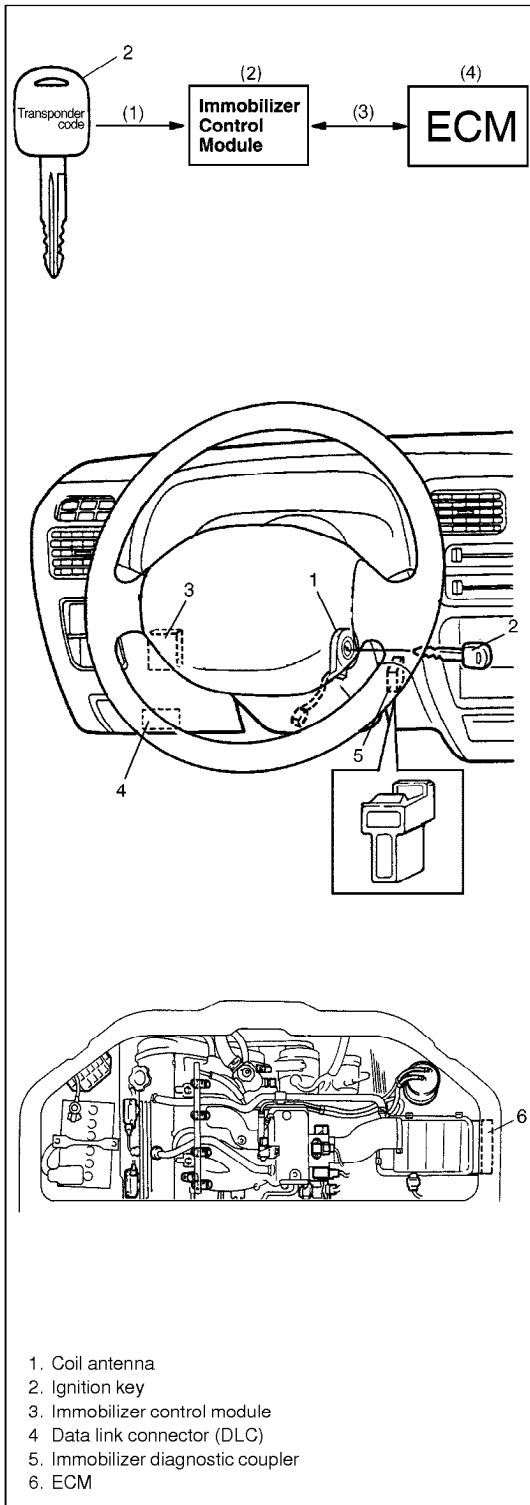

1. Coil antenna
2. Ignition key
3. Immobilizer control module
4. Data link connector (DLC)
5. Immobilizer diagnostic coupler
6. ECM

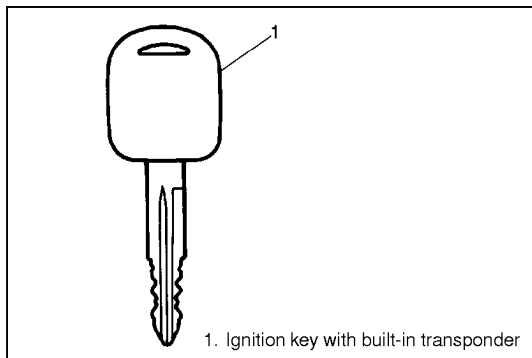
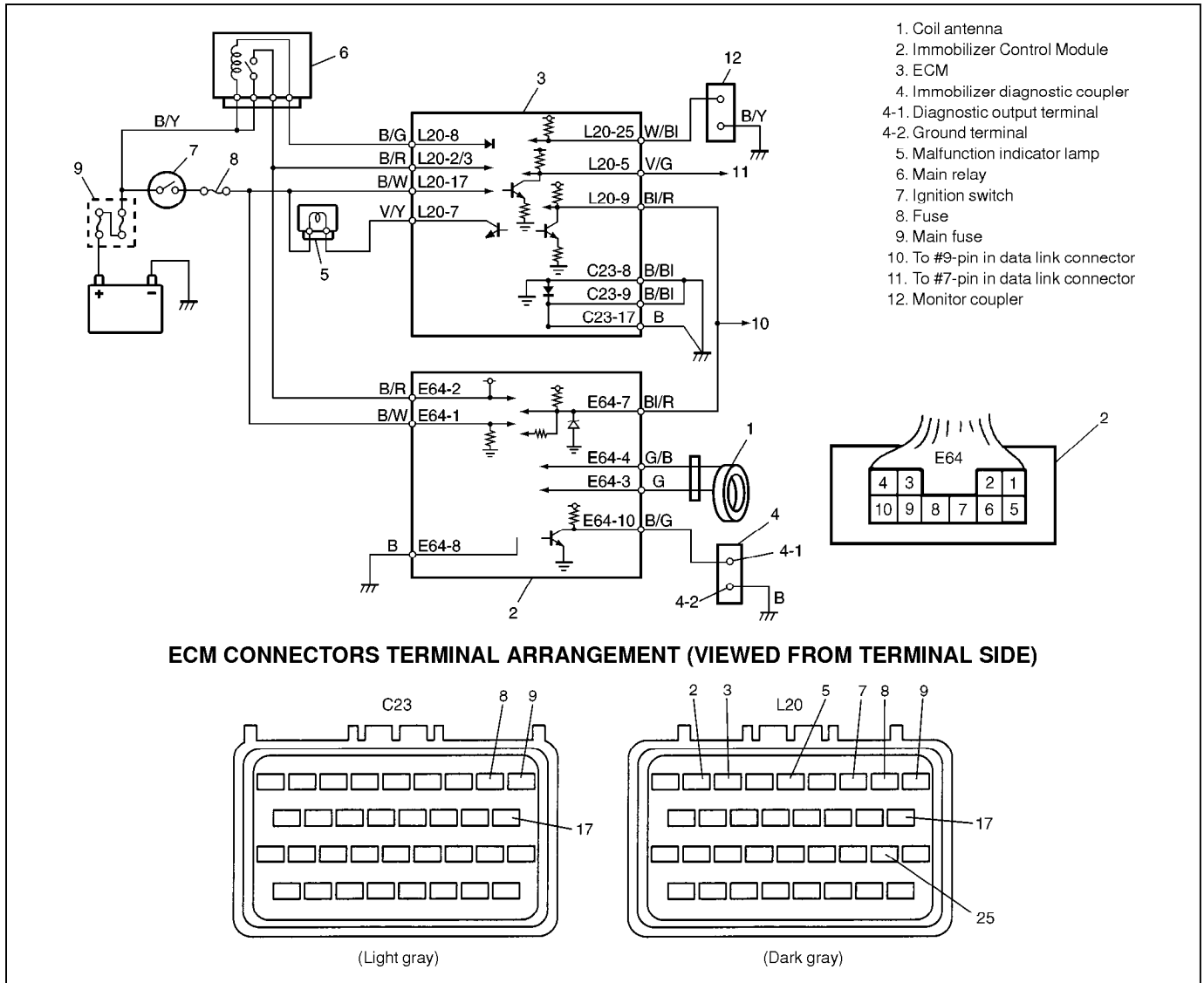

IGNITION KEY

The ignition key for the immobilizer control system has a built-in transponder. Each transponder in the key has an each transmitting code (Transponder code). The code will transmitted from the key via the coil antenna to Immobilizer Control Module when the ignition switch is turned ON.

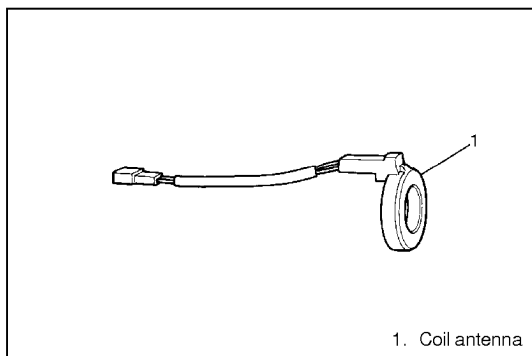

COIL ANTENNA

The coil antenna is installed to the steering lock assembly. As it is energized by Immobilizer Control Module, it transmits the transponder code of the ignition key to Immobilizer Control Module.

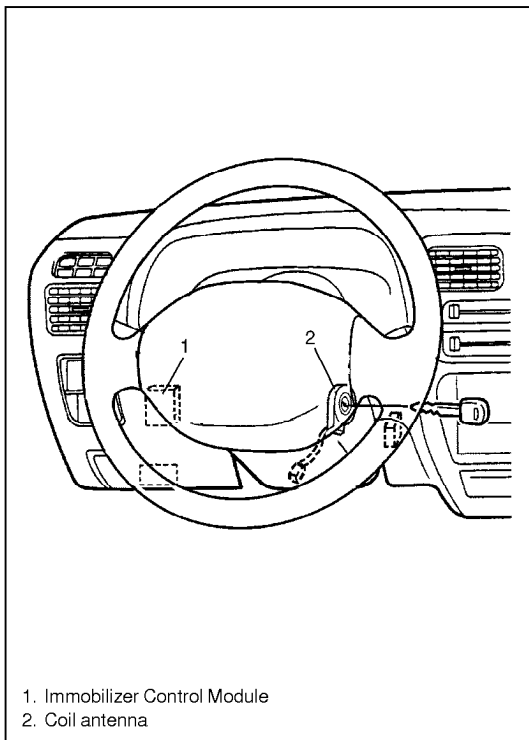

IMMOBILIZER CONTROL MODULE

Immobilizer Control Module is installed to the underside of the instrument panel at the driver's seat side.

As main functions, Immobilizer Control Module checks matching not only between the Transponder Code transmitted from the ignition key and that registered in Immobilizer Control Module (Up to 4 different Transponder codes can be registered.) but also between the ECM/Immobilizer Control Module code transmitted from ECM and that registered in Immobilizer Control Module. In addition, it has an on-board diagnostic system (self-diagnosis function) which is described in "On-Board Diagnostic System (Self-Diagnosis Function)" in this section.

ECM

As main functions, ECM not only checks matching of ECM/Immobilizer Control Module code but also has an on-board diagnostic system (self-diagnosis function) as described in "On-Board Diagnostic System (Self-Diagnosis Function)" in this section.

For installation position of ECM, refer to Section 6E.

ON-BOARD DIAGNOSTIC SYSTEM (SELF-DIAGNOSIS FUNCTION)

Immobilizer Control Module and ECM diagnose troubles which may occur in the area including the following parts when the ignition switch is ON.

- | | | | |
|------|---------------------------------------|-----------------------------|---------------------------------------|
| ECM: | ● ECM/Immobilizer Control Module code | Immobilizer Control Module: | ● Transponder code |
| | ● Serial data link circuit | | ● Coil antenna |
| | ● ECM | | ● ECM/Immobilizer Control Module code |
| | | | ● Serial data link circuit |
| | | | ● Immobilizer Control Module |
| | | | ● Ignition signal |

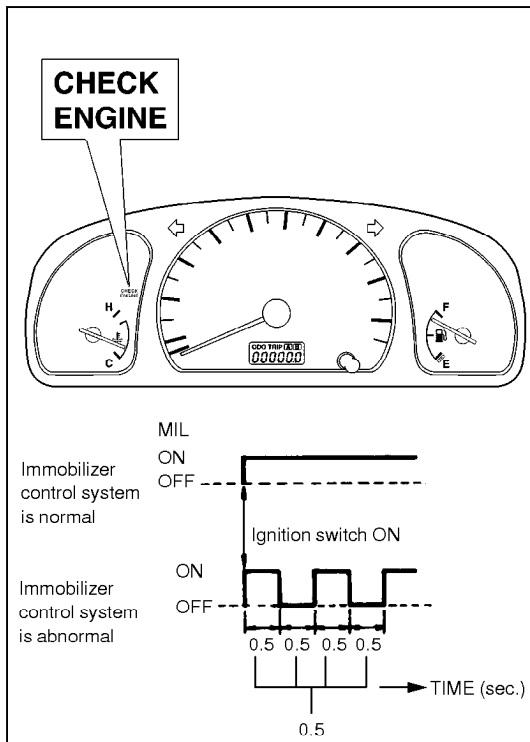

With the diagnosis switch terminal of monitor coupler for ECM not grounded, the ignition switch turned ON (but the engine at stop) and regardless of the condition of the engine and emission control system, ECM indicates whether a trouble has occurred in the immobilizer control system or not by causing the malfunction indicator lamp to flash or turn ON.

Malfunction indicator lamp is ON:

No trouble exists in the immobilizer control system.

Malfunction indicator lamp is flashing:

ECM or Immobilizer Control Module has detected some trouble in the immobilizer control system.

NOTE:

As soon as the ignition switch is turned ON, ECM and Immobilizer Control Module diagnose if a trouble has occurred in the immobilizer control system. While the diagnosis is being made, the malfunction indicator lamp stays ON and if the diagnosis result is "abnormal", it immediately changes to flashing but if the result is "normal", it remains ON. Diagnosis takes about 3 seconds at maximum.

When ECM and Immobilizer Control Module detects a trouble which has occurred in the above areas, it stores DTC corresponding to the exact trouble area in ECM and Immobilizer Control Module memory.

DTCs stored in memory of each controller (Immobilizer Control Module and ECM) can be read by using the procedure described in "DIAGNOSTIC TROUBLE CODE CHECK (IMMOBILIZER CONTROL MODULE)" and "DIAGNOSTIC TROUBLE CODE CHECK(ECM)" in this section.

DIAGNOSIS

PRECAUTIONS IN DIAGNOSING TROUBLES

PRECAUTIONS IN IDENTIFYING DIAGNOSTIC TROUBLE CODE

ECM

- Before identifying diagnostic trouble code indicated by malfunction indicator lamp or Suzuki scan tool, don't disconnect couplers from ECM, battery cable from battery, ECM ground wire harness from engine. Such disconnection will clear trouble codes for engine and emission control system and immobilizer control system stored in memory of ECM.
- If abnormality or malfunction lies in two or more areas, malfunction indicator lamp indicates applicable codes three times each. And flashing of these codes is repeated as long as diagnosis terminal is grounded and ignition switch is held at ON position.
- When ECM detects a trouble in both engine and emission control system and immobilizer control system, malfunction indicator lamp indicates trouble codes of both systems alternately while the ignition switch is turned ON and the diagnosis terminal is grounded.
- Take a note of diagnostic trouble code indicated first.

Immobilizer Control Module

- Before identifying diagnostic trouble code indicated by analog type voltmeter, do not disconnect couplers from immobilizer control module, battery cable from battery and/or immobilizer control module ground wire harness from engine. Such disconnection will clear trouble codes stored in memory of immobilizer control module.
- Take a note of diagnostic trouble code indicated first.

INTERMITTENT TROUBLES

- There are cases where output of diagnostic output terminal, malfunction indicator lamp and/or Suzuki scan tool indicate a diagnostic trouble code representing a trouble which occurred only temporarily and has gone. In such case, it may occur that good parts are replaced unnecessarily. To prevent such accident, be sure to follow instructions given below when checking by using "Diagnostic Flow Table".
 - * When trouble can be identified, it is not an intermittent one:
Check coil antenna, ignition key, wires and each connection and if they are all in good condition, substitute a known-good ECM and recheck.
 - * When trouble can not be identified but output of diagnostic output terminal, malfunction indicator lamp and/or Suzuki scan tool indicate a trouble code:
Diagnose trouble by using that code No. and if ignition key, coil antenna, wires and each connection are all in good condition, turn OFF ignition switch and then ON.

Then check what malfunction indicator lamp, output of diagnostic output terminal and/or Suzuki scan tool indicate. Only when they indicate trouble code again, substitute a known-good ECM or Immobilizer Control Module and check again.

If they indicate not trouble code but normal code, it means that an intermittent trouble did occur and has gone. In this case, check wires and connections carefully again.

DIAGNOSTIC FLOW TABLE

STEP	ACTION	YES	NO
1	1) Make sure that diagnosis switch terminal in monitor coupler is not grounded by service wire. See Fig. 1. 2) Check malfunction indicator lamp while ignition switch is ON (but without starting engine). See Fig. 2. Does malfunction indicator lamp flash?	Go to Step 3.	<ul style="list-style-type: none"> • If malfunction indicator lamp remains ON, go to Step 2. • If malfunction indicator lamp remains OFF, go to "MALFUNCTION INDICATOR LAMP CHECK" in Section 6.
2	1) Using service wire, ground diagnosis switch terminal in monitor coupler. See Fig. 3. Does malfunction indicator lamp flash?	Immobilizer control system is in good condition.	Go to "MALFUNCTION INDICATOR LAMP CHECK" in Section 6.
3	Does malfunction indicator lamp flash as Fig. 4?	Go to Step 4.	Go to "MALFUNCTION INDICATOR LAMP CHECK" in Section 6.
4	1) Check DTC stored in immobilizer control module referring to "DIAGNOSTIC TROUBLE CODE CHECK (IMMOBILIZER CONTROL MODULE)" in this section. Is there any DTC(s)?	Go to flow table for DTC No.	Go to Step 5.
5	1) Check DTC stored in ECM referring to "DIAGNOSTIC TROUBLE CODE CHECK (ECM)" in this section. Is there any DTC(s)?	Go to flow table for DTC No.	Substitute a known-good ECM and recheck. NOTE: After replacing with a known-good ECM, register ECM/Immobilizer Control Module code in ECM by performing procedure described in "Procedure after ECM Replacement" section.

Fig. 1 for Step 1

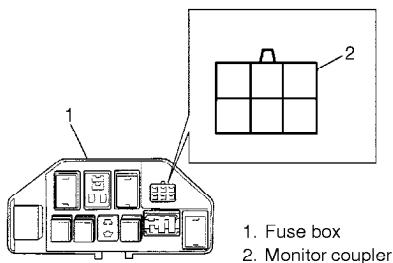

Fig. 2 for Step 1

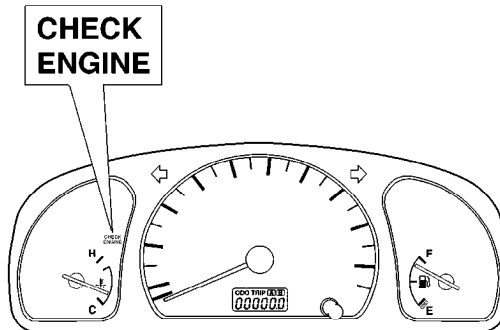

Fig. 3 for Step 2 and Step 5

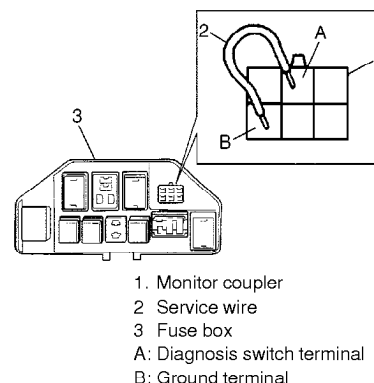
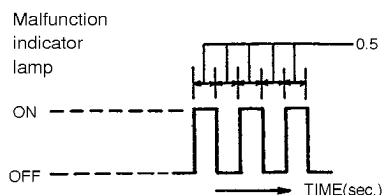
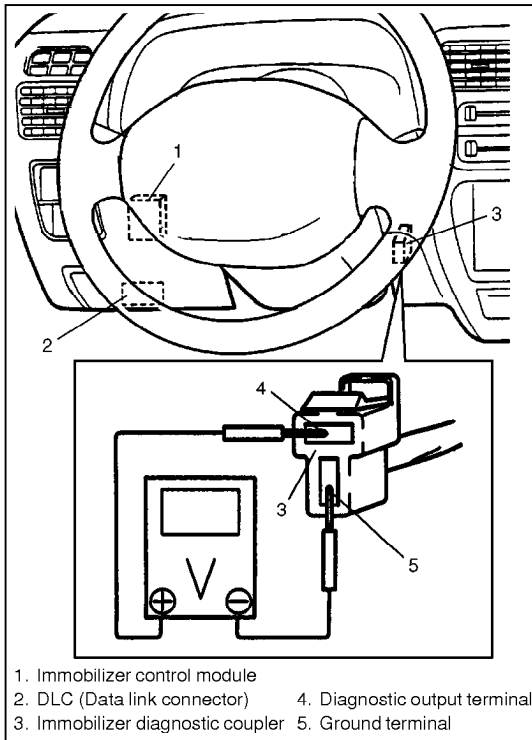

Fig. 4 for Step 3





DIAGNOSTIC TROUBLE CODE (DTC) CHECK (IMMOBILIZER CONTROL MODULE)

- 1) Using analog type voltmeter, connect positive probe to diagnostic output terminal and negative probe to ground of immobilizer diagnostic coupler with ignition switch turned ON.
- 2) Read deflection of voltmeter indicator which represents DTC as shown in example below and write it down. For details of DTC, refer to Immobilizer Control Module side in "Diagnostic Trouble Code Table".

If voltmeter indicator does not deflect, go to "Diagnostic Flow Table A".

NOTE:

If abnormality or malfunction lies in two or more areas, voltmeter indicator lamp indicates applicable codes three times each.

EXAMPLE: ● COIL ANTENNA FAILURE (CODE NO. 13)

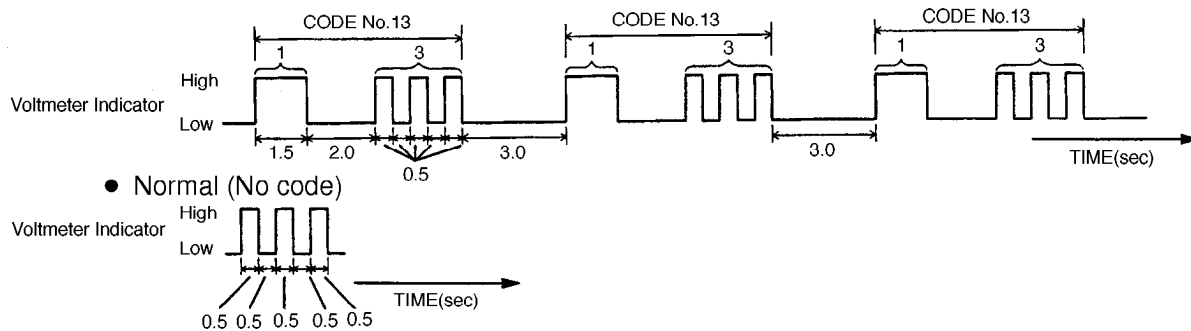

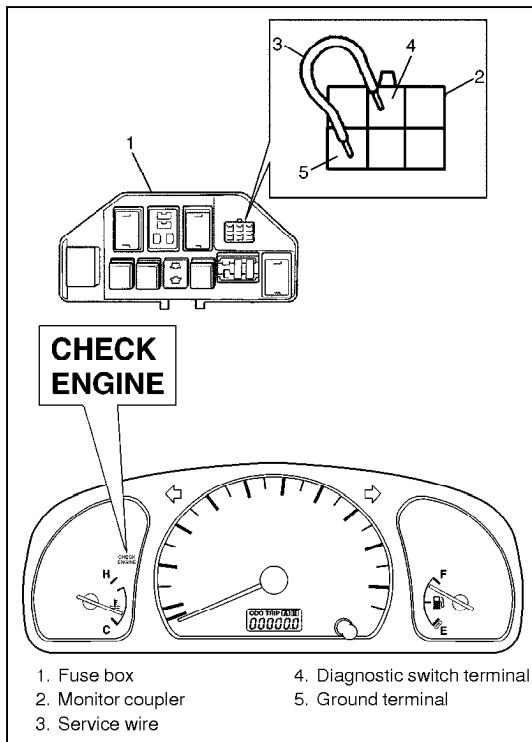

DIAGNOSTIC TROUBLE CODE (DTC) CHECK (ECM)

[Not using SUZUKI scan tool]

- 1) Using service wire, ground diagnostic switch terminal in monitor coupler.
- 2) Read DTC from flashing pattern of malfunction indicator lamp as shown in example below and write it down. For details of DTC, refer to ECM side in "Diagnostic Trouble Code Table". If lamp remains ON, go to "Malfunction Indicator Lamp Check" in Section 6.

NOTE:

If abnormality or malfunction lies in two or more areas, malfunction indicator lamp indicates applicable codes three times each.

And flashing of these codes is repeated as long as diagnosis terminal is grounded and ignition switch is held at ON position.

EXAMPLE: When serial data link wire is defective (Code No.83)

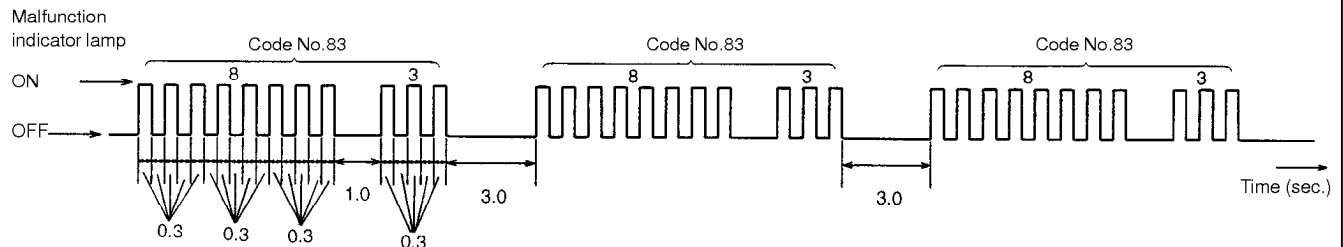

- 3) After completing the check, turn ignition switch OFF and disconnect service wire from monitor coupler.

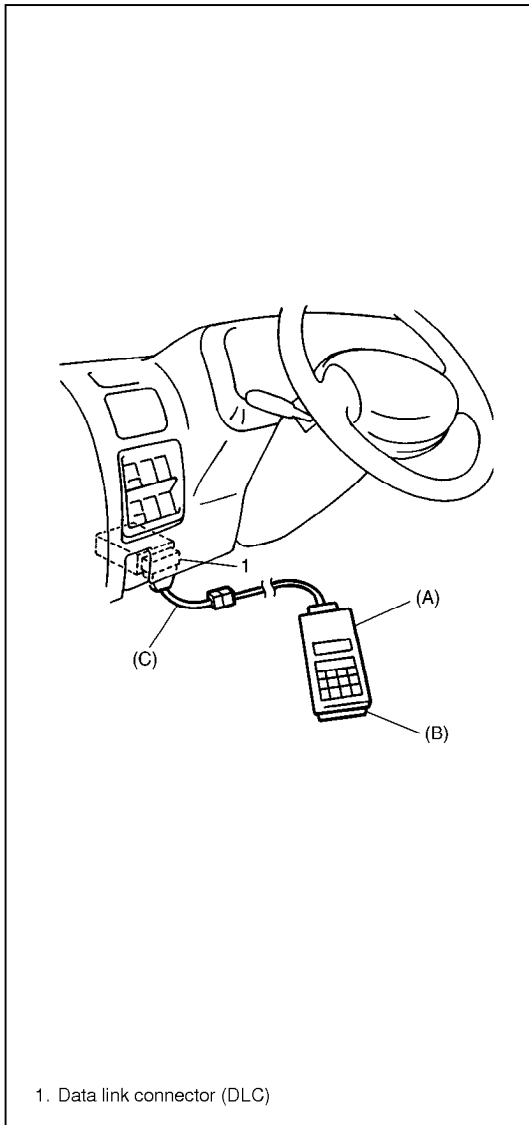
**[Using SUZUKI scan tool]**

- 1) Turn ignition switch OFF.
- 2) After setting cartridge to Suzuki scan tool, connect it to data link connector (DLC) located on underside of instrument panel at driver's seat side.

Special Tool**(A): 09931-76011 (Suzuki scan tool)****(B): Mass storage cartridge****(C): 09931-76030 (16/14 pin DLC cable)**

- 3) Turn ignition switch ON.
- 4) Read DTC stored in ECM according to instructions displayed on Suzuki scan tool and print it or write it down. Refer to Suzuki scan tool operator's manual for further details.







NOTE:

- When reading DTC stored in ECM using Suzuki scan tool, select "ECM" from the applications menu and "SUZUKI mode" from the communication mode menu displayed on Suzuki scan tool.
- If ECM detects a trouble in both engine and emission control system and immobilizer control system, Suzuki scan tool indicates trouble codes of both systems using Suzuki mode of ECM application.

If communication between Suzuki scan tool and ECM is not possible, check if Suzuki scan tool is communicable by connecting it to ECM in another vehicle. If communication is possible in this case, Suzuki scan tool is in good condition. Then check data link connector and serial data line (circuit) in the vehicle with which communication was not possible.

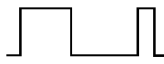
- 5) After completing the check, turn ignition switch OFF and disconnect Suzuki scan tool from data link connector (DLC).

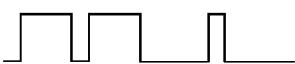
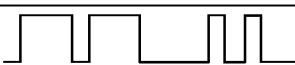
DIAGNOSTIC TROUBLE CODE TABLE**Immobilizer Control Module**

DTC (indicated by voltmeter indicator)	VOLTMETER INDICATION	DIAGNOSTIC AREA	DIAGNOSIS
—		Normal (No code)	This code appears when none of the other codes are identified.
11		Transponder code	Diagnose trouble according to "Diagnostic Flow Table" corresponding to each code No.
31			
12		Immobilizer Control Module	
13		Coil antenna or ignition key with built-in transponder	
21		ECM/Immobilizer Control Module code	
22		Ignition switch circuit	
23		Serial data link circuit	

ECM

To learn how to read diagnostic trouble code (DTC) from flashing of malfunction indicator lamp, refer to Section 6E.





DTC (indicated on Suzuki scan tool)	DTC (indicated by MIL)	Malfunction Indicator lamp (MIL) flashing pattern	DIAGNOSTIC AREA	DIAGNOSIS
NO DTC	12		Normal	This code appears when it is confirmed that none of other trouble codes is set for immobilizer control system or engine and emission control system.
P1623	81		ECM/Immobilizer Control Module code	Diagnose trouble according to "DIAGNOSTIC FLOW TABLE" corresponding to each code No.
P1620	84			
P1622	82		ECM	
P1621	83		Serial data link wire	

TABLE A DTC IS NOT OUTPUT FROM DIAGNOSTIC OUTPUT TERMINAL

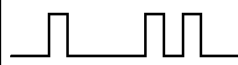

STEP	ACTION	YES	NO
1	Check voltage between E64-2 terminal and body ground with ignition switch turned ON. Is it 10 – 14V?	Go to Step 2.	"B/R" wire open.
2	1) Connect voltmeter between E64-10 terminal and body ground. 2) Does voltmeter indicator deflect?	Go to Step 3.	<ul style="list-style-type: none"> ● Poor E64-2, E64-10 or E64-8 connection. ● "B" wire of E64-8 terminal open. ● "B/G" wire between E64-10 terminal and diagnostic output terminal of immobilizer diagnostic coupler short. If wire and connections are OK, substitute a known-good Immobilizer Control Module and recheck. NOTE: After replacing with a known-good Immobilizer Control Module, register ECM/Immobilizer Control Module code in ECM and Transponder code and ECM/Immobilizer Control Module code in Immobilizer Control Module by performing procedure described in "Procedure After Immobilizer Control Module Replacement".
3	1) Connect voltmeter between diagnostic output terminal of immobilizer diagnostic coupler and body ground. 2) Is it possible to read DTC by checking deflection of voltmeter indicator?	"B" wire of ground terminal for immobilizer diagnostic coupler open.	"B/G" wire between E64-10 terminal and diagnostic output terminal of immobilizer diagnostic coupler open.

DTC11 TRANSPONDER CODE NOT MATCHED

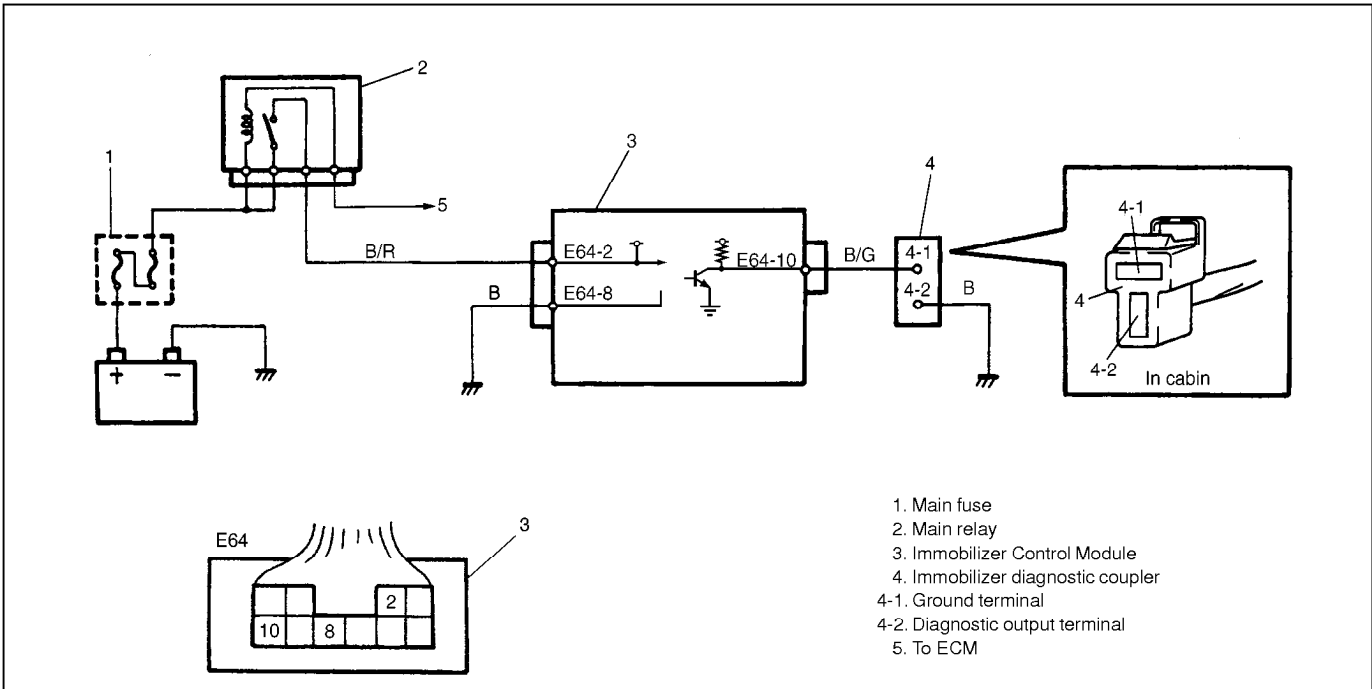
DESCRIPTION:

Immobilizer Control Module checks if Transponder code transmitted from ignition key and that registered in Immobilizer Control Module match when ignition switch is ON. If they do not, DTC 11 is set.

INSPECTION:

Register ignition key with built-in transponder by using SUZUKI scan tool and performing following steps.

- 1) Register Transponder code in Immobilizer Control Module by performing procedure described in "How To Register Ignition Key".
- 2) Turn ignition switch OFF, then turn it ON and check that DTC11 is not set.

DTC31 TRANSPONDER CODE NOT REGISTERED

DESCRIPTION:

Immobilizer Control Module checks if Transponder code transmitted from ignition key and that registered in Immobilizer Control Module match when ignition switch is ON. If there is no Transponder code registered in Immobilizer Control Module, this DTC is set.

INSPECTION:

Register ignition key with built-in transponder by using SUZUKI scan tool and performing following steps.

- 1) Register Transponder code in Immobilizer Control Module by performing procedure described in "How To Register Ignition Key".
- 2) Turn ignition switch OFF, then turn it ON and check that DTC31 is not set.

DTC12 FAULT IN IMMOBILIZER CONTROL MODULE

DESCRIPTION:

This DTC is set when an internal fault is detected in Immobilizer Control Module.

INSPECTION:

STEP	ACTION	YES	NO
1	1) Ignition switch OFF. 2) Disconnect connectors from Immobilizer Control Module. 3) Check for proper connection to Immobilizer Control Module at all terminals. Are they in good condition?	Substitute a known-good Immobilizer Control Module and recheck. NOTE: After replacing with a known-good Immobilizer Control Module, register ECM/Immobilizer Control Module code in ECM and Transponder code and ECM/Immobilizer Control Module code in Immobilizer Control Module by performing procedure described in "Procedure After Immobilizer Control Module Replacement".	Repair or replace.

DTC13 NO TRANSPONDER CODE TRANSMITTED OR COIL ANTENNA OPENED/SHORTED

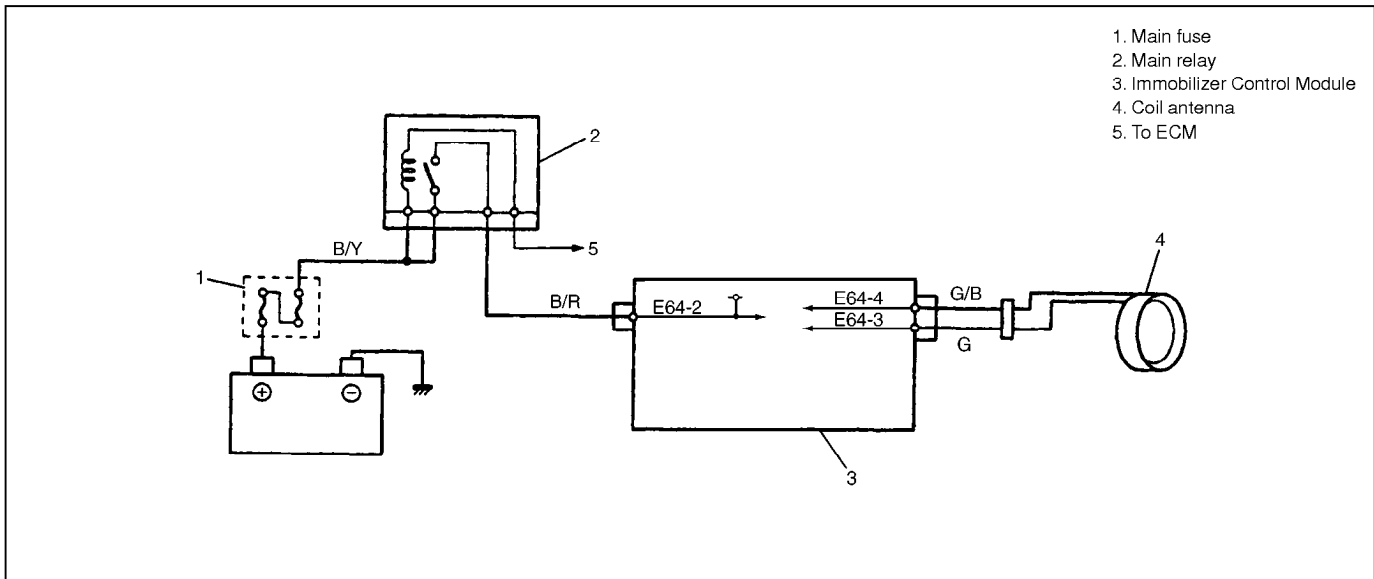

DESCRIPTION:

Immobilizer Control Module energizes the coil antenna when the ignition switch is ON and reads Transponder code from the ignition key. When Immobilizer Control Module cannot read Transponder code from the ignition key even when the coil antenna is energized, this DTC is set.

INSPECTION:

STEP	ACTION	YES	NO
1	Dose ignition key being used have built-in transponder? (See Fig. 1)	Go to Step 2.	Replace ignition key with built-in transponder and follow "DIAGNOSTIC FLOW TABLE" again.
2	1) Disconnect coil antenna coupler with ignition switch turned OFF. 2) Is there continuity between coil antenna coupler terminals A and B? (See Fig. 2)	Go to Step 3.	Coil antenna open.
3	Measure resistance between terminals of coil antenna coupler and body ground. (See Fig. 3) Is it ∞ (infinity) Ω ?	Go to Step 4.	Coil antenna shorted to ground.
4	1) With coil antenna coupler disconnected, disconnect Immobilizer Control Module coupler. 2) Measure resistance between coil antenna terminals of Immobilizer Control Module coupler. (See Fig. 4) Is it ∞ (infinity) Ω ?	Go to Step 5.	"G/B" wire shorted to "G" wire.
5	Measure resistance between terminal E64-4 of Immobilizer Control Module coupler and body ground. (See Fig. 5) Is it ∞ (infinity) Ω ?	Go to Step 6.	"G/B" wire shorted to ground.
6	Measure resistance between terminal E64-3 of Immobilizer Control Module coupler and body ground. (See Fig. 6) Is it ∞ (infinity) Ω ?	Go to Step 7.	"G" wire shorted to ground.

STEP	ACTION	YES	NO
7	1) Connect coil antenna coupler. 2) Is there continuity between Immobilizer Control Module coupler terminals E64-4 and E64-3? (See Fig. 7)	Go to Step 8.	<ul style="list-style-type: none"> • "G/B" or "G" wire open • Poor coil antenna-to-coupler
8	1) If connections are OK, connect Immobilizer Control Module coupler and substitute a known-good coil antenna. 2) Is DTC 13 also indicated with ignition switch turned ON?	Go to Step 9.	Faulty coil antenna.
9	Is DTC 13 still indicated even when another ignition key (with built-in transponder) for that vehicle used?	Substitute a known-good Immobilizer Control Module and recheck. NOTE: After replacing with a known-good Immobilizer Control Module, register ECM/ Immobilizer Control Module code in ECM and Transponder code and ECM/Immobilizer Control Module code in Immobilizer Control Module by performing procedure described in "Procedure After Immobilizer Control Module Replacement".	Faulty transponder.

Fig. 1 for step 1

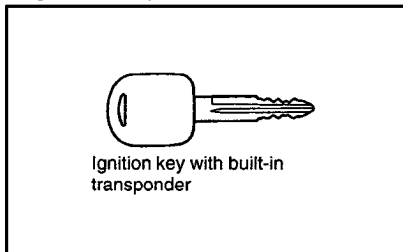

Fig. 2 for step 2

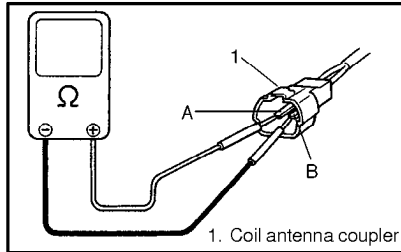

Fig. 3 for step 3

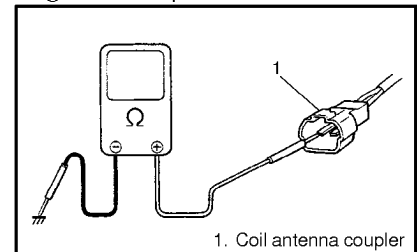

Fig. 4 for step 4

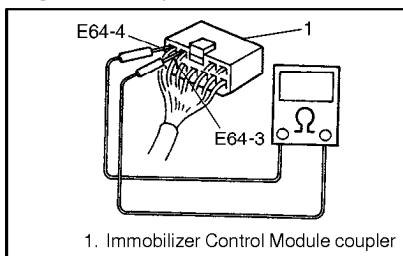

Fig. 5 for step 5

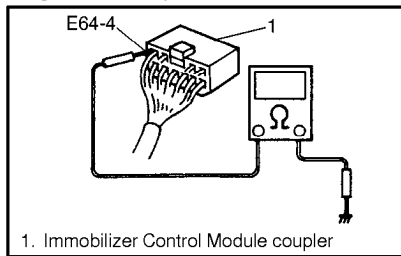

Fig. 6 for step 6

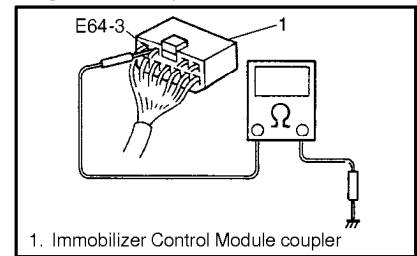
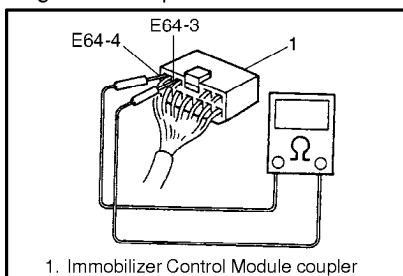

Fig. 7 for step 7



**DTC21 ECM/IMMOBILIZER CONTROL MODULE CODE NOT MATCHED
(IMMOBILIZER CONTROL MODULE SIDE)****DTC81 ECM/IMMOBILIZER CONTROL MODULE CODE NOT MATCHED
(P1623) (ECM SIDE)****DTC84 ECM/IMMOBILIZER CONTROL MODULE CODE NOT REGISTERED
(P1620)****DESCRIPTION:**

● DTC21

Immobilizer Control Module checks if ECM/Immobilizer Control Module code transmitted from ECM and that registered in Immobilizer Control Module match when ignition switch is ON. If they do not, this DTC is set.

● DTC81 (P1623)

ECM checks if ECM/Immobilizer Control Module code transmitted from Immobilizer Control Module and that registered in ECM match when ignition switch is ON. If they do not, this DTC is set.

● DTC84 (P1620)

ECM checks if code transmitted from Immobilizer Control Module and that registered in ECM match when ignition switch is ON. If there is no ECM/Immobilizer Control Module code registered in ECM, this DTC is set.

INSPECTION:

Perform procedure described in "Procedure After ECM Replacement".

DTC82 (P1622) FAULT IN ECM**DESCRIPTION:**

This DTC is set when an internal fault is detected in ECM.

INSPECTION:

STEP	ACTION	YES	NO
1	1) Ignition switch OFF. 2) Disconnect connectors from ECM. 3) Check for proper connection to ECM at all terminals. Are they in good condition?	Substitute a known-good ECM and re-check. NOTE: After replacing with a known-good ECM, register ECM/Immobilizer Control Module code in ECM by performing procedure described in "Procedure After ECM Replacement".	Repair or replace.

DTC22 IGNITION SWITCH CIRCUIT OPEN/SHORT

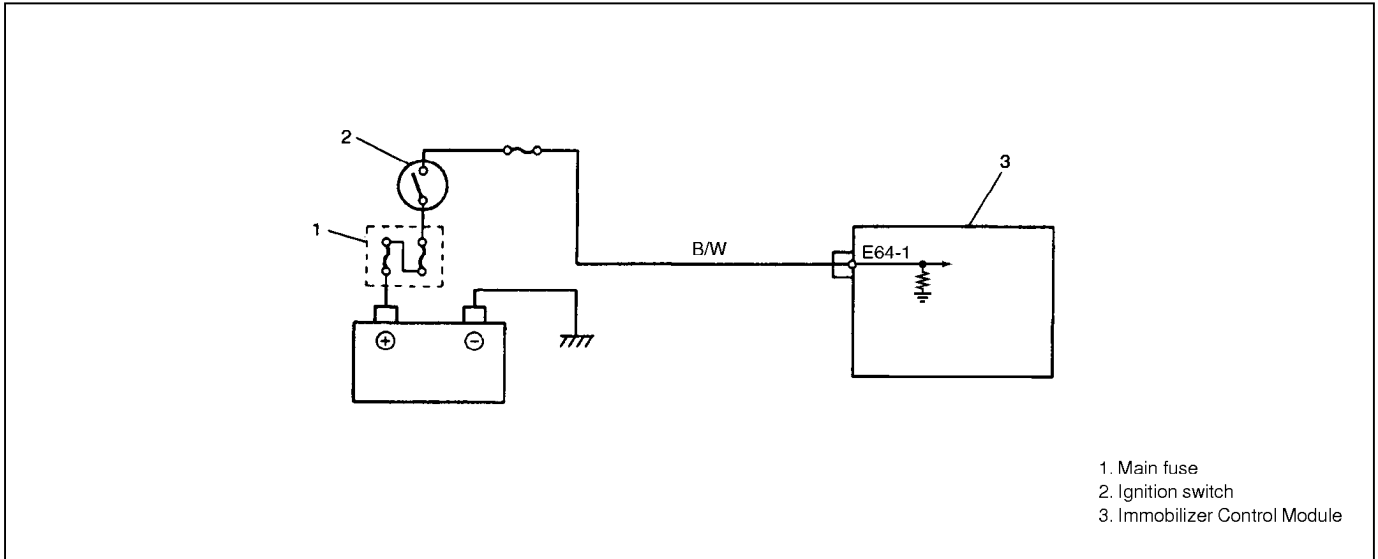

DESCRIPTION:

Immobilizer Control Module monitors ignition signal when the ignition switch is ON. This DTC is set when no ignition signal input is detected by Immobilizer Control Module.

INSPECTION:

STEP	ACTION	YES	NO
1	<p>Check voltage between Immobilizer Control Module coupler terminal E64-1 and body ground with ignition switch turned ON. (See Fig.1)</p> <p>Is it 10 – 14V?</p>	<p>Poor E64-1 terminal connection. If connection is OK, substitute a known-good Immobilizer Control Module and recheck.</p> <p>NOTE: After replacing with a know-good Immobilizer Control Module, register ECM/Immobilizer Control Module code in ECM and Transponder code and ECM/Immobilizer Control Module code in Immobilizer Control Module by performing procedure described in “Procedure After Immobilizer Control Module Replacement”.</p>	<p>“B/W” wire open or short.</p>

Fig. 1 for step 1

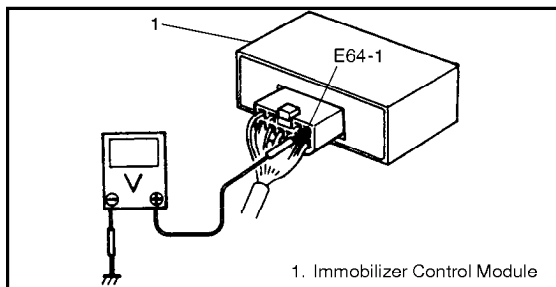

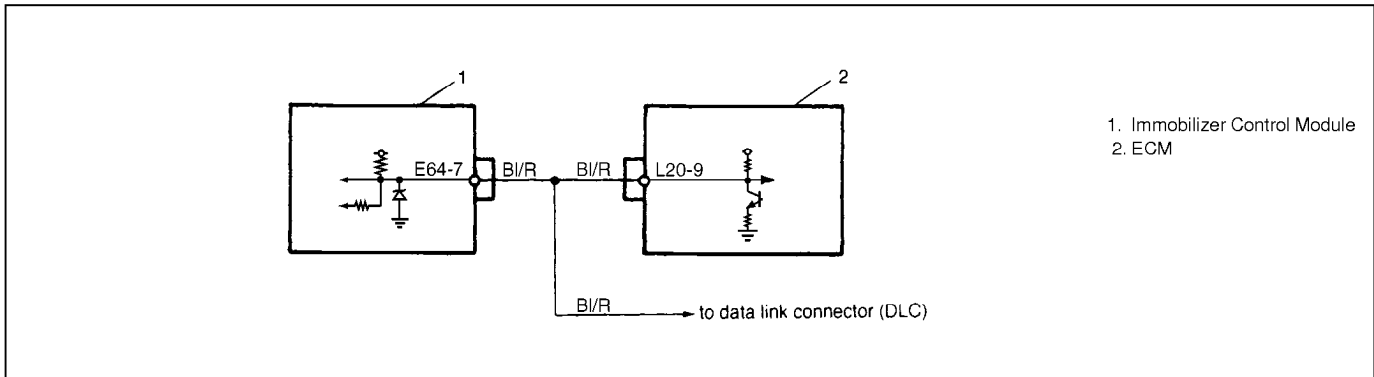
DTC23 NO ECM/IMMOBILIZER CONTROL MODULE CODE TRANSMITTED FROM ECM OR DLC CIRCUIT OPENED/SHORTED**DTC83 NO ECM/IMMOBILIZER CONTROL MODULE CODE TRANSMITTED (P1621) FROM IMMOBILIZER CONTROL MODULE OR DLC CIRCUIT OPENED/SHORTED****DESCRIPTION:**

When the ignition switch is ON, Immobilizer Control Module requests ECM and ECM requests Immobilizer Control Module to transmit ECM/Immobilizer Control Module code. If ECM/Immobilizer Control Module code is not transmitted from ECM or Immobilizer Control Module, Immobilizer Control Module sets DTC23 and ECM sets DTC83.

INSPECTION:

STEP	ACTION	YES	NO
1	Check voltage between Immobilizer Control Module coupler terminal E64-7 and body ground with ignition switch turned ON. (See Fig. 1) Is it 4 – 5V?	Go to Step 2.	"BI/R" wire short.
2	1) Disconnect ECM coupler with ignition switch turned OFF. 2) Is there continuity between Immobilizer Control Module coupler terminal E64-7 and serial data link terminal (L20-9) of ECM coupler? (For positions of Data link connector terminal of ECM coupler, refer to "General Description" in this section.)	Poor E64-7 terminal connection or poor data link connector terminal connection (ECM) If connections are OK, substitute a known-good ECM or Immobilizer Control Module and recheck. NOTE: <ul style="list-style-type: none"> After replacing with a known-good ECM, register ECM/Immobilizer Control Module code in ECM by performing procedure described in "Procedure After ECM Replacement". After replacing with a known-good Immobilizer Control Module, register ECM/Immobilizer Control Module code in ECM and Transponder code and ECM/Immobilizer Control Module code in Immobilizer Control Module by performing procedure described in "Procedure After Immobilizer Control Module Replacement". 	"BI/R" wire between Immobilizer Control Module and ECM open.

Fig. 1 for step 1

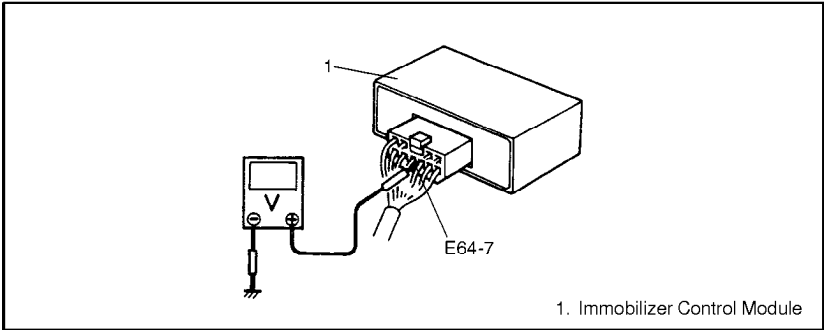
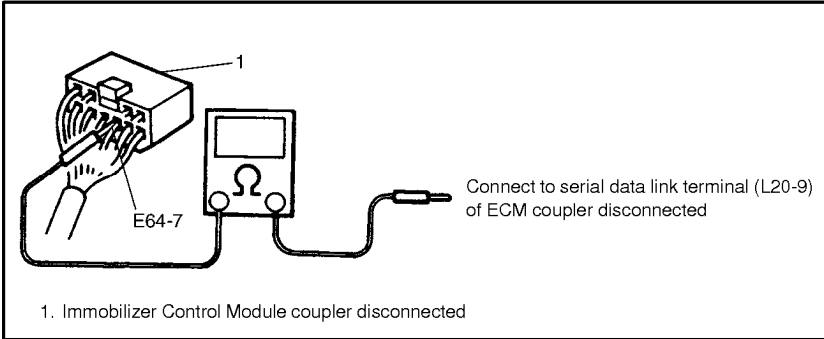
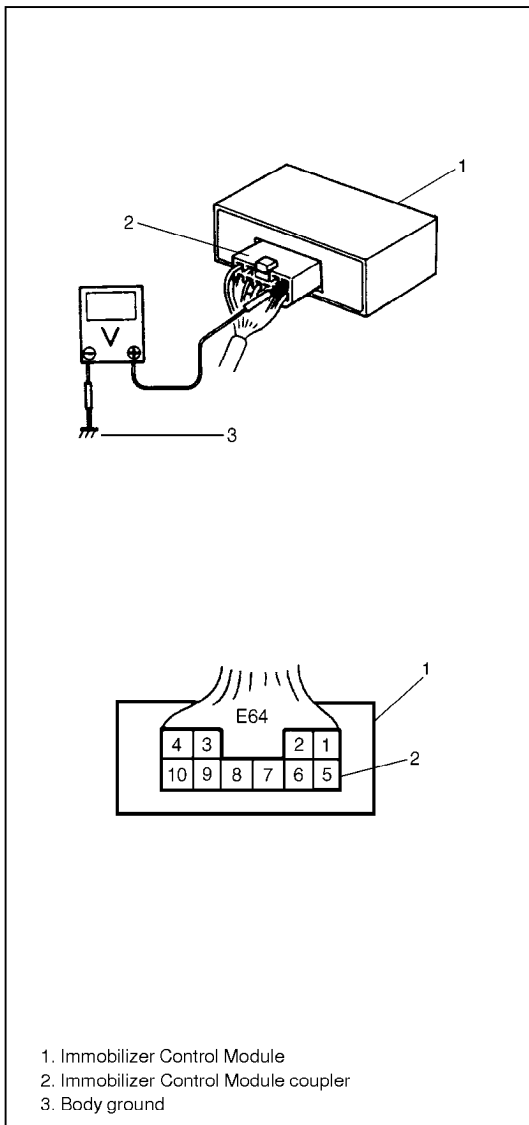

Fig. 2 for step 2





INSPECTION OF ECM, IMMOBILIZER CONTROL MODULE AND ITS CIRCUIT

ECM, Immobilizer Control Module and its circuit can be checked at ECM wiring couplers and Immobilizer Control Module wiring coupler by measuring voltage. Described here is only inspection of Immobilizer Control Module. For inspection of ECM, refer to Section 6E.

CAUTION:

Immobilizer Control Module cannot be checked by itself. It is strictly prohibited to connect voltmeter or ohmmeter to Immobilizer Control Module with coupler disconnected from it.

Voltage Check

- 1) Remove Immobilizer Control Module, referring to "IMMOBILIZER CONTROL MODULE" for removal in this section.
- 2) Connect Immobilizer Control Module coupler to Immobilizer Control Module.
- 3) Check voltage at each terminal of coupler connected.

NOTE:

As each terminal voltage is affected by the battery voltage, confirm that it is 11V or more when ignition switch is ON.

TERMINAL	CIRCUIT	NORMAL VOLTAGE	CONDITION
E64-1	Ignition signal	10 – 14V	Ignition switch ON
		0 – 0.8V	Ignition switch OFF
E64-2	Power source	10 – 14V	Ignition switch ON
E64-3	Coil antenna 1	0V	Ignition switch ON
E64-4	Coil antenna 2	0V	Ignition switch ON
E64-5 E64-6	Blank	—	—
E64-7	Data link connector (Serial data terminal)	4 – 5V	Ignition switch ON
E64-8	Ground	—	—
E64-9	Blank	—	—
E64-10	Diagnosis output	0 – 14V	Ignition switch ON
		0V	Ignition switch OFF

NOTE:

When measuring voltage at E64-4 and E64-3 terminals with ignition switch turned ON, be sure to turn ignition switch ON before connecting positive probe of voltmeter to E64-4 or E64-3 terminal. If it is not turned ON first, DTC13 (Diagnostic Trouble Code 13) may be indicated.

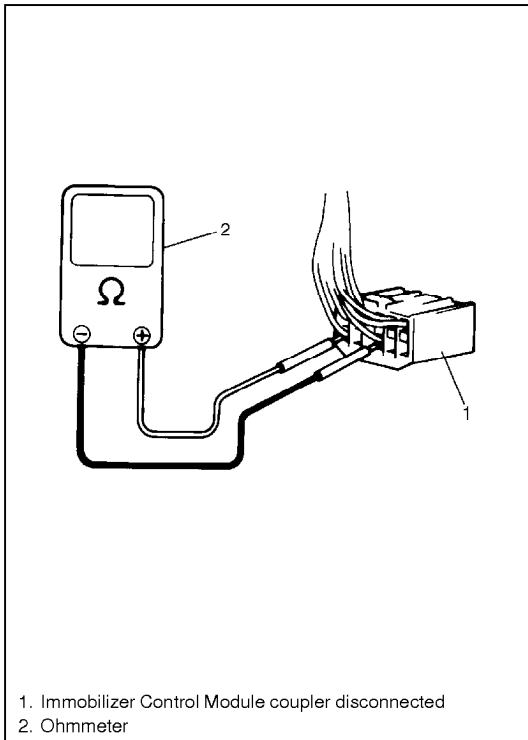

Resistance Check

- 1) Disconnect Immobilizer Control Module couplers from Immobilizer Control Module with ignition switch OFF.

CAUTION:

Never touch terminals of Immobilizer Control Module itself or connect voltmeter or ohmmeter.

- 2) Check resistance between each terminal of couplers disconnected.

CAUTION:

- Be sure to connect ohmmeter probe from wire harness side of coupler.
- Be sure to turn OFF ignition switch for this check.
- Resistance in table below represents that when parts temperature is 20°C (68°F).

TERMINAL	CIRCUIT	NORMAL RESISTANCE	CONDITION
E64-4 – E64-3	Coil antenna	Continuity	—

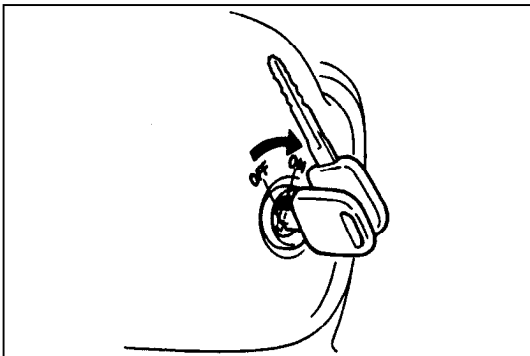

ON-VEHICLE SERVICE

PRECAUTIONS IN HANDLING IMMOBILIZER CONTROL SYSTEM

- Don't turn ON ignition switch with ignition key for immobilizer control system put together with another one or placed quite close to another one. Or the system may detect abnormal condition and prevent engine from starting.

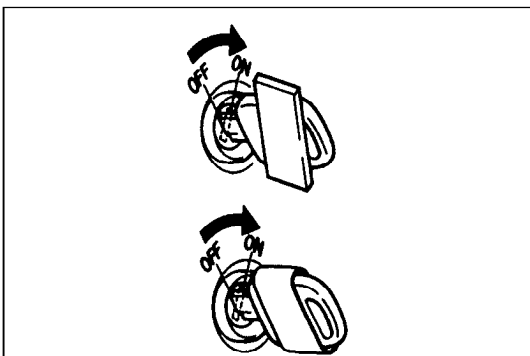

- Do not turn ON ignition switch by using ignition key with any type of metal wound around its grip or in contact with it. Or the system may detect abnormal condition and prevent engine from starting.

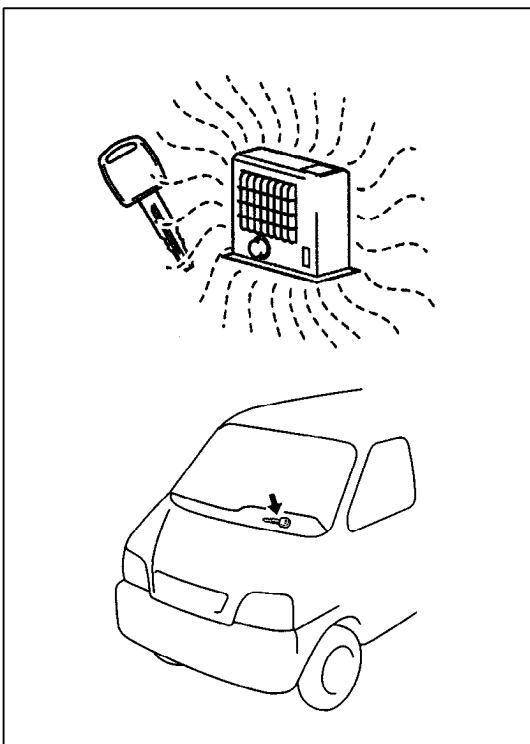

- Do not leave ignition key where high temperature is anticipated. High temperature will cause transponder in ignition key to be abnormal or damaged.

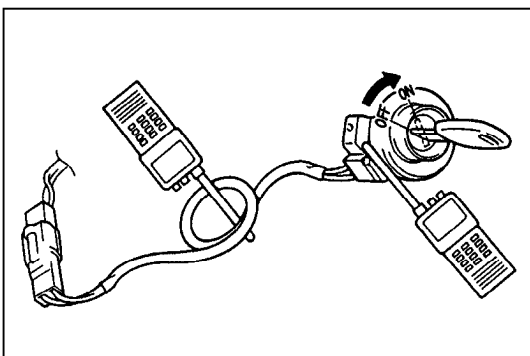

- Do not turn ON ignition switch with a radio antenna placed near coil antenna or its harness to Immobilizer Control Module. Or the system may detect abnormal condition and prevent engine from starting.

IMMOBILIZER CONTROL MODULE

Removal

- 1) Disconnect negative (-) cable at battery.
- 2) Disconnect coupler at Immobilizer Control Module.
- 3) Remove immobilizer control module.

Installation

Reverse removal procedure for installation.

NOTE:

After replacing Immobilizer Control Module, be sure to register Transponder code and ECM/Immobilizer Control Module code in Immobilizer Control Module and ECM/Immobilizer Control Module code in ECM by performing procedure described in "Procedure After Immobilizer Control Module Replacement".

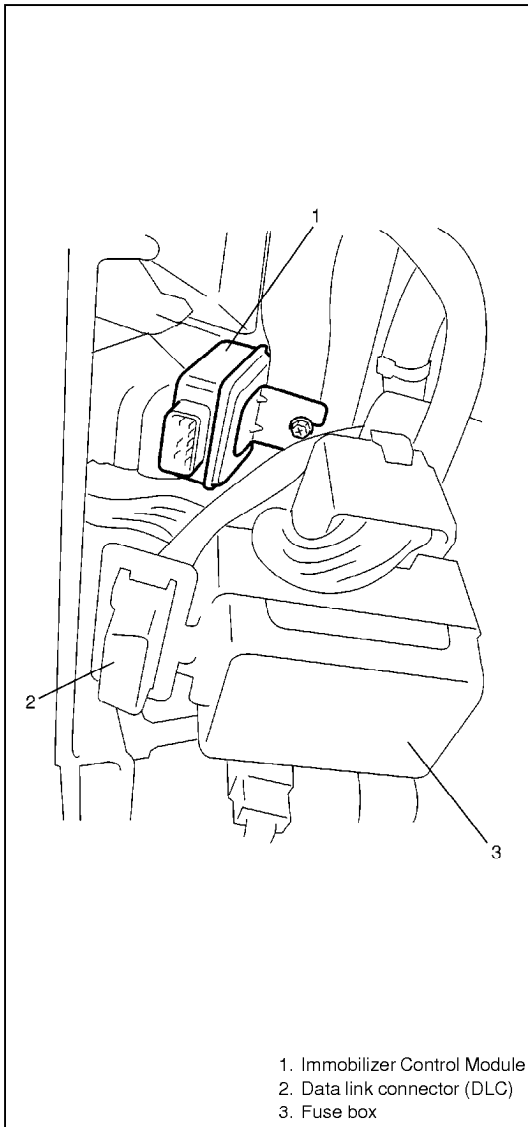

COIL ANTENNA

Removal

- 1) Disconnect negative (-) cable at battery.
- 2) Loosen steering column upper mounting bolts, then remove steering column upper and lower cover.

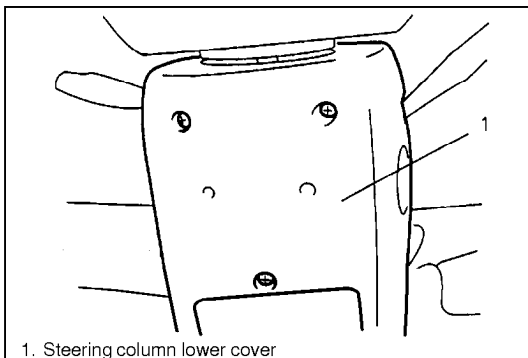

- 4) Remove coil antenna.

Installation

For installation, reverse removal procedure.

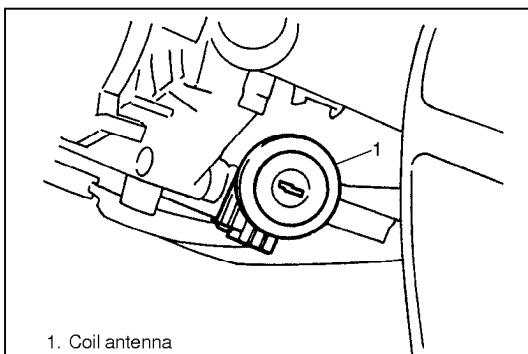

HOW TO REGISTER IGNITION KEY

Register the ignition key with a built-in transponder in Immobilizer Control Module by using the following procedure.

- 1) Prepare SUZUKI scan tool and cartridge for immobilizer control system.
- 2) With ignition switch OFF, connect SUZUKI scan tool to data link connector (DLC) located on underside of instrument panel at driver's seat side.

(A): 09931-76011 (SUZUKI scan tool)

(B): Immobilizer cartridge

(C): 09931-76030 (16/14 pin DLC cable)

NOTE:

For operation procedure of SUZUKI scan tool, refer to SUZUKI scan tool operator's manual.

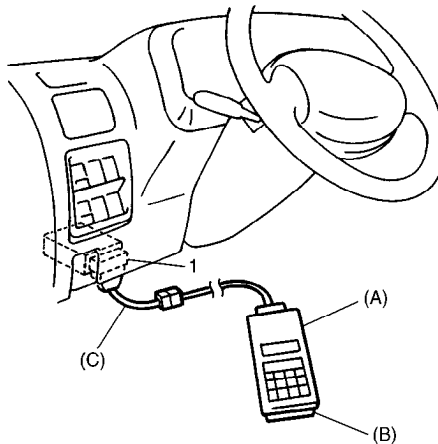

1. Data link connector (DLC)

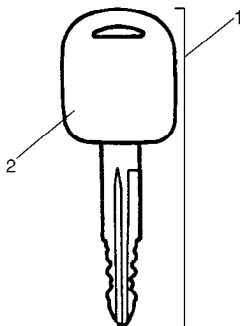

1. Ignition key with built-in transponder
2. Key knob

- 3) Prepare ignition key with a built-in transponder. And then turn ignition switch ON by using it.
- 4) Number of Transponder codes for ignition key with a built-in transponder that can be registered in Immobilizer Control Module is limited to 4. If needed, clear all Transponder codes for ignition key with a built-in transponder that have been registered in Immobilizer Control Module by executing the "CLR. TRANS COD (CLEAR TP CODE)" command in the SELECT MODE menu by using SUZUKI scan tool.

NOTE:

When "CLR. TRANS COD (CLEAR TP CODE)" command is executed with the malfunction indicator lamp (if not equipped with immobilizer indicator lamp) ON or the immobilizer indicator lamp ON, it remains ON even after execution of that command is over. It will start flashing when the ignition switch is turned OFF once and then turned ON after some seconds.

- 5) Using SUZUKI scan tool, register Transponder code in Immobilizer Control Module by executing “ENT. TRANS COD (ENT. TP CODE)” command in SELECT MODE menu.
- 6) Make sure that malfunction indicator lamp lights when ignition switch is turned OFF once and then ON.
- 7) If any other Transponder code for ignition key with a built-in transponder needs to be registered, repeat above steps 3), 5) and 6).

NOTE:

- Up to 4 Transponder codes for ignition key with a built-in transponder can be registered.
- It is not possible to register the same Transponder code for ignition key with a built-in transponder as the one already registered in Immobilizer Control Module.

PROCEDURE AFTER IMMOBILIZER CONTROL MODULE REPLACEMENT

When Immobilizer Control Module was replaced, including when replaced because rechecking by using a known-good Immobilizer Control Module was necessary during trouble diagnosis, register Transponder code and ECM/Immobilizer Control Module code in Immobilizer Control Module and ECM/Immobilizer Control Module code in ECM by performing following procedure.

- 1) Perform steps 1) and 2) described in “How To Register Ignition Key”.
- 2) Prepare ignition key with a built-in transponder. And then turn ignition switch ON by using it.
- 3) Using SUZUKI scan tool, clear all transponder codes registered in Immobilizer Control Module by executing “CLR. TRANS COD (CLEAR TP CODE)” command in SELECT MODE menu.

NOTE:

When “CLR. TRANS COD (CLEAR TP CODE)” command is executed with the malfunction indicator lamp (if not equipped with immobilizer indicator lamp) ON or the immobilizer indicator lamp ON, it remains ON even after execution of that command is over. It will start flashing when the ignition switch is turned OFF once and then turned ON after some seconds.

- 4) Using SUZUKI scan tool, register Transponder code in Immobilizer Control Module by executing “ENT. TRANS COD (ENT. TP CODE)” command in SELECT MODE menu.
- 5) Using SUZUKI scan tool, register ECM/Immobilizer Control Module code in both Immobilizer Control Module and ECM by executing “RECORD ECU (RECORD ECM/PCM/ICM)” command in SELECT MODE menu.
- 6) Make sure that malfunction indicator lamp lights when ignition switch is turned OFF once and then ON.
- 7) If any other Transponder code for ignition key with a built-in transponder needs to be registered, repeat above steps 2), 4) and 6).

NOTE:

- Up to 4 Transponder codes for ignition key with a built-in transponder can be registered.
- It is not possible to register the same Transponder code for ignition key with a built-in transponder as the one already registered in Immobilizer Control Module.

PROCEDURE AFTER ECM REPLACEMENT

When ECM was replaced, including when replaced because re-checking by using a known-good ECM was necessary during trouble diagnosis, register ECM/Immobilizer Control Module code in ECM by performing following procedure.

- 1) Perform steps 1) and 2) described in “How To Register Ignition Key”. And then turn ignition switch ON.
- 2) Using SUZUKI scan tool, register ECM/Immobilizer Control Module code in ECM by executing “RECORD ECU (RECORD ECM/ICM)” command in SELECT MODE menu.

NOTE:

For operation procedure of SUZUKI scan tool, refer to SUZUKI scan tool operator’s manual.

- 3) Make sure that malfunction indicator lamp lights when ignition switch is turned OFF once and then ON.

SPECIAL TOOLS

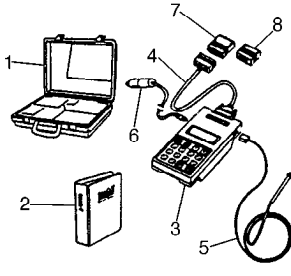
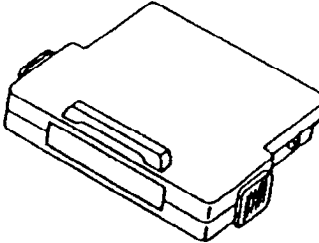
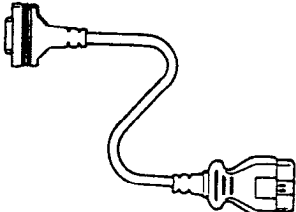
 <p>1. Storage case 2. Operator's manual 3. Tech 1A 4. DLC cable 5. Test lead/probe 6. Power source cable 7. DLC cable adaptor 8. Self-test adaptor</p> <p>09931-76011 SUZUKI scan tool (Tech 1A) kit</p>	 <p>Immobilizer cartridge of version 1.1 or more</p>	 <p>09931-76030 16/14 pin DLC cable</p>
--	--	--

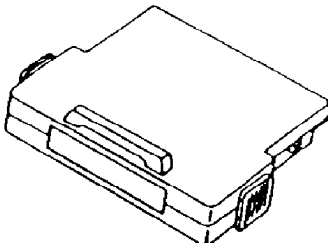

Mass storage cartridge of version 1.6 or more

SECTION 9

BODY SERVICE

WARNING:

For vehicles equipped with Supplemental Restraint (Air Bag) System:

- Service on and around the air bag system components or wiring must be performed only by an authorized SUZUKI dealer. Refer to AIR BAG SYSTEM COMPONENTS AND WIRING LOCATION VIEW of GENERAL DESCRIPTION in air bag system section in order to confirm whether you are performing service on or near the air bag system components or wiring. Please observe all WARNINGS and SERVICE PRECAUTIONS of ON-VEHICLE SERVICE in air bag system section before performing service on or around the air bag system components or wiring. Failure to follow WARNINGS could result in unintentional activation of the system or could render the system inoperative. Either of these two conditions may result in severe injury.
- Technical service work must be started at least 90 seconds after the ignition switch is turned to the LOCK position and negative cable is disconnected from the battery. Otherwise, the system may be activated by reserve energy in the Sensing and Diagnostic Module (SDM).

NOTE:

For the descriptions (items) not found in this section, refer to the same section of the Service Manual mentioned in the FOREWORD of this manual.

CONTENTS

METAL REPLACEMENT PARTS FINISHING .. 9- 2	BODY DIMENSIONS 9- 9
Sealant Application Area 9- 2	UNDERBODY DIMENSIONS 9-11
Rust-Proof Treatment Area 9- 7	

METAL REPLACE PARTS FINISHING

SEALANT APPLICATION AREA

Van model

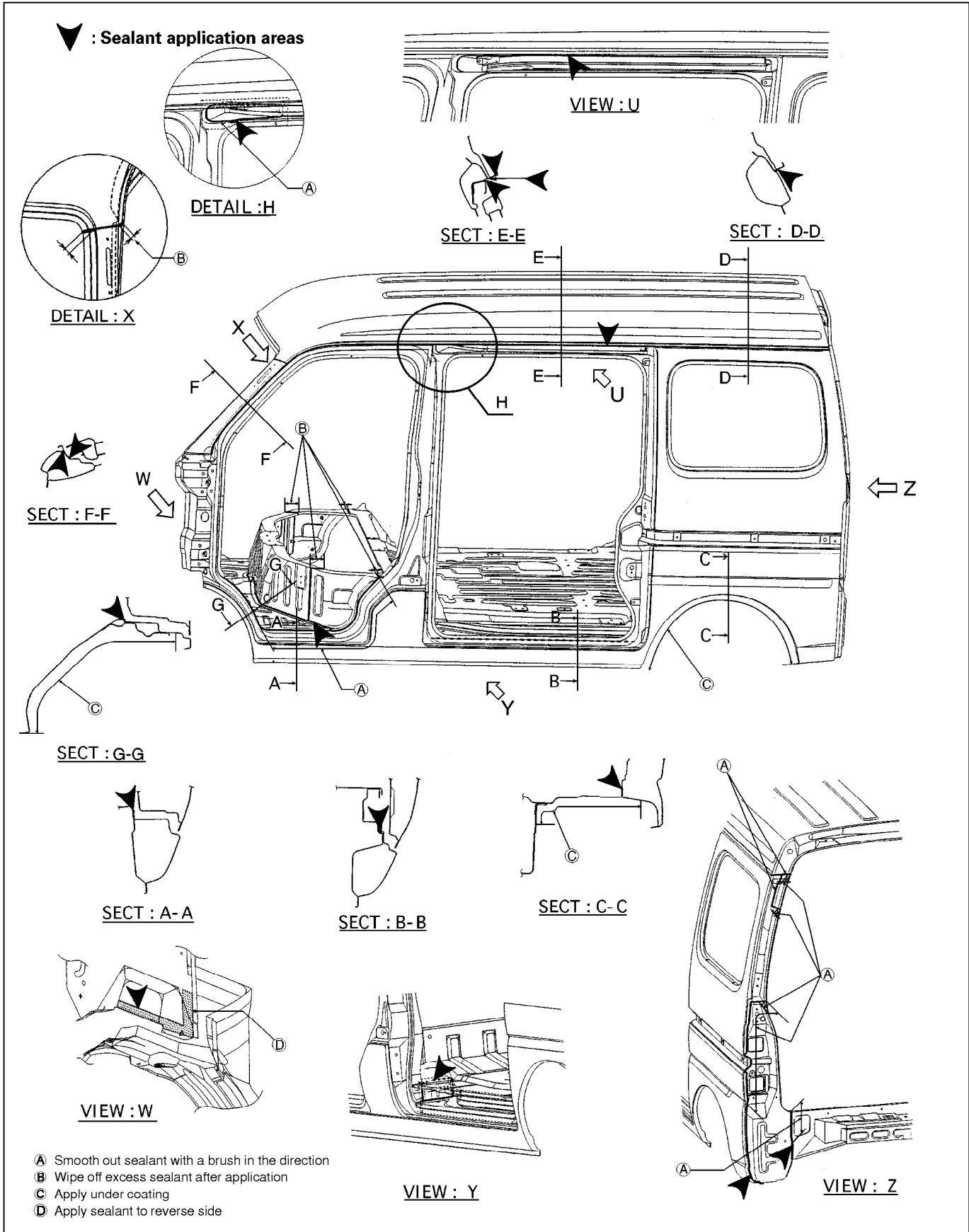

▼ : Sealant application areas

- A Smooth out sealant with a brush in the direction
- B Wipe off excess sealant after application
- C Apply under coating

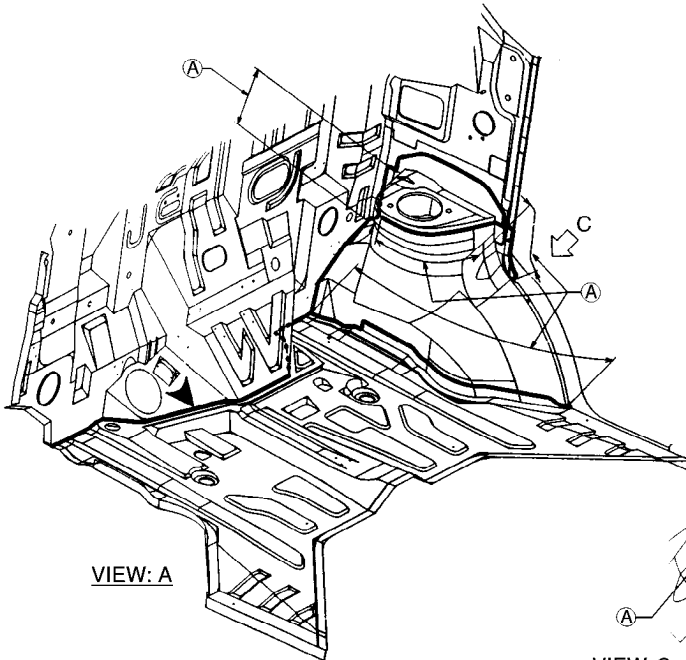
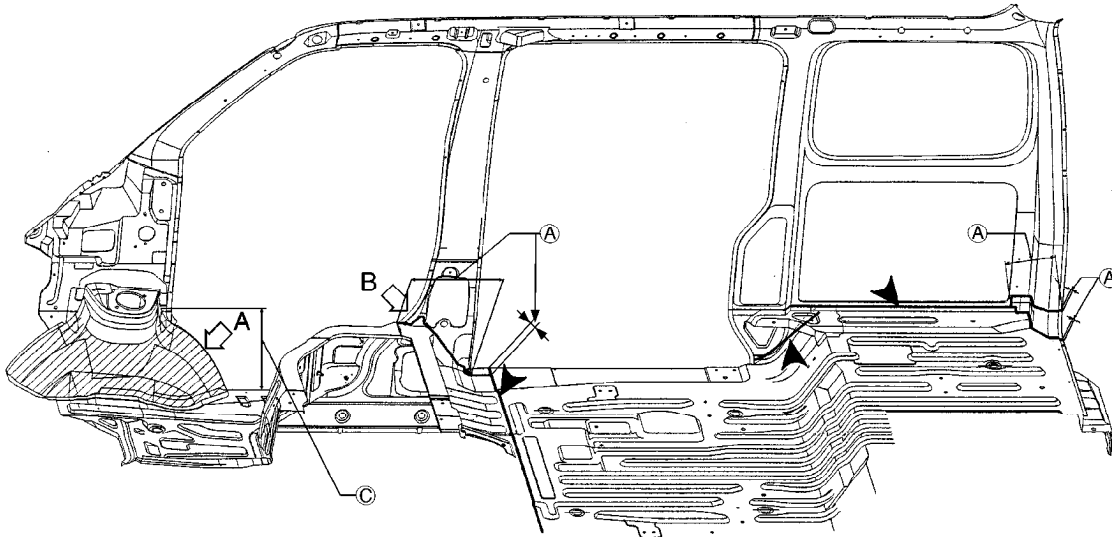

VIEW: A

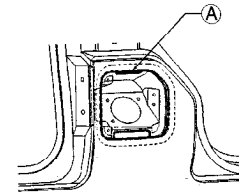

VIEW: B
(RH ONLY)

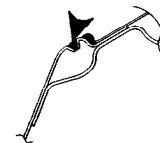

SECT: M-M

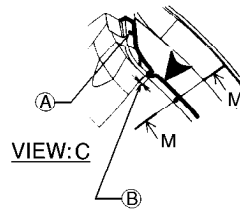

VIEW: C



SECT: D-D

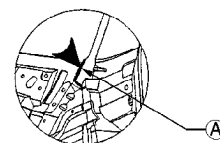
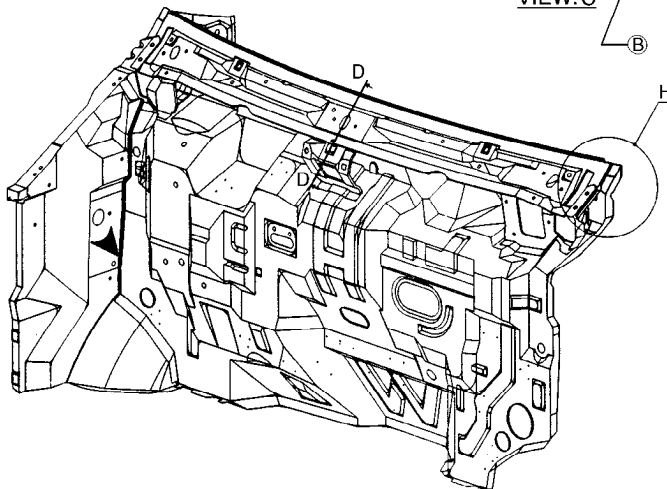

DETAIL: E

FRONT DOOR

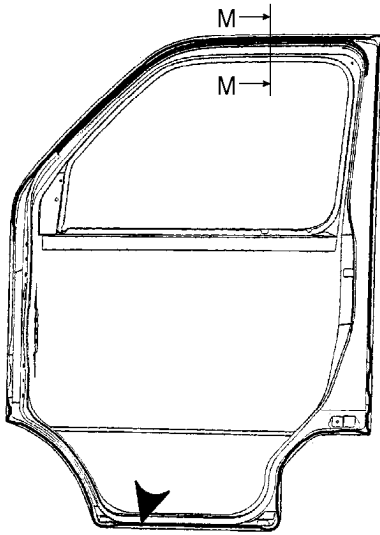

SECT : M-M

▲ : Apply sealant

HOOD

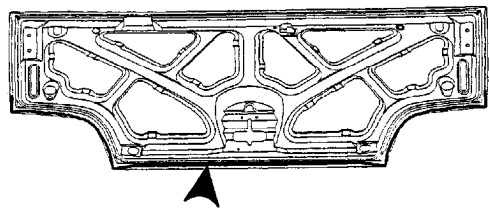

REAR DOOR

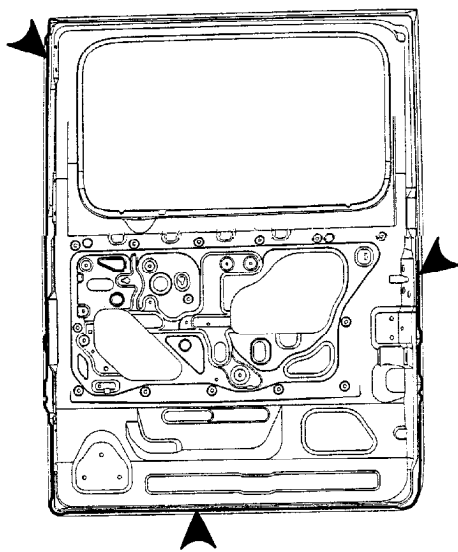

BACK DOOR

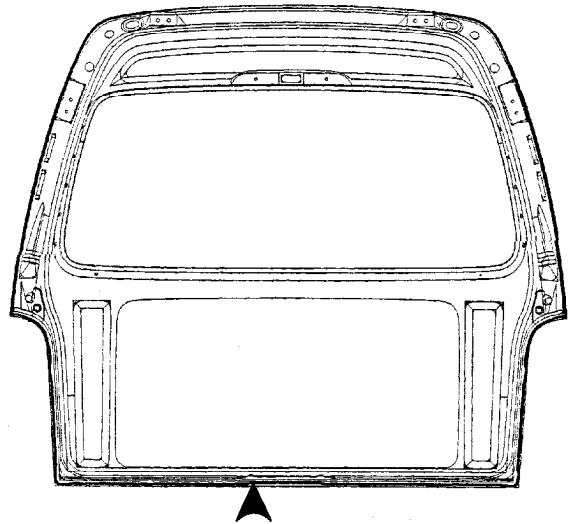

Truck model

▼ : Sealant application areas

※ : Refer to the figure of van model

- A Smooth out sealant with a brush in the direction
- B Wipe off excess sealant after application
- C Apply under coating
- D Apply sealant to reverse side

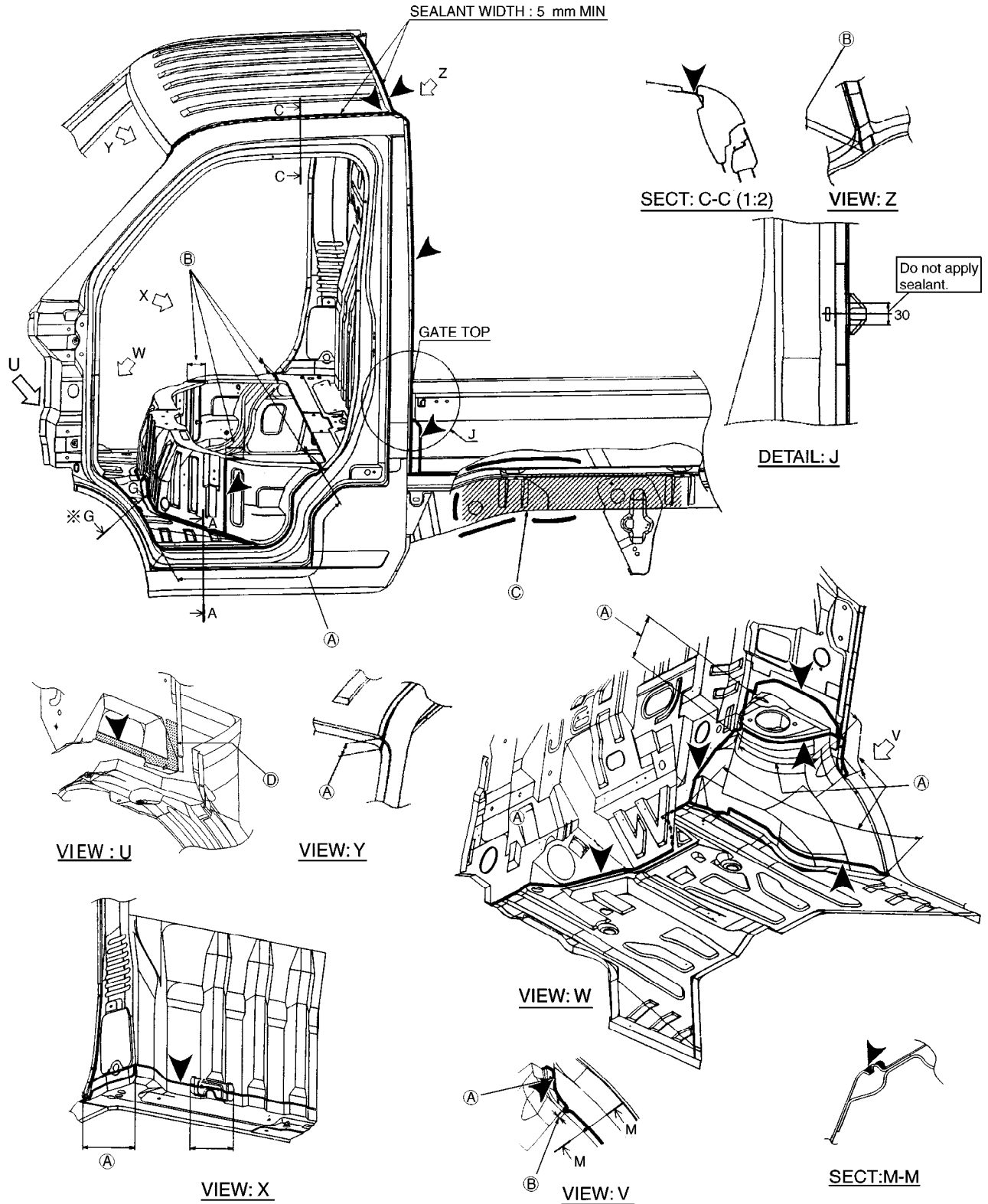

▼ : Sealant application areas
※ : Refer to the figure of van model

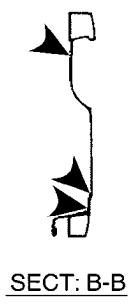
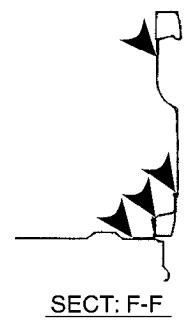
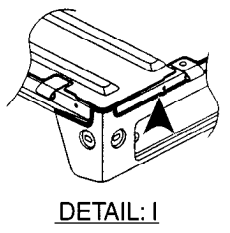
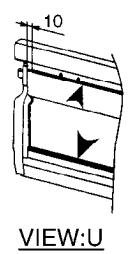
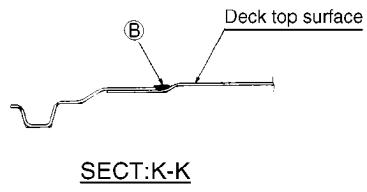
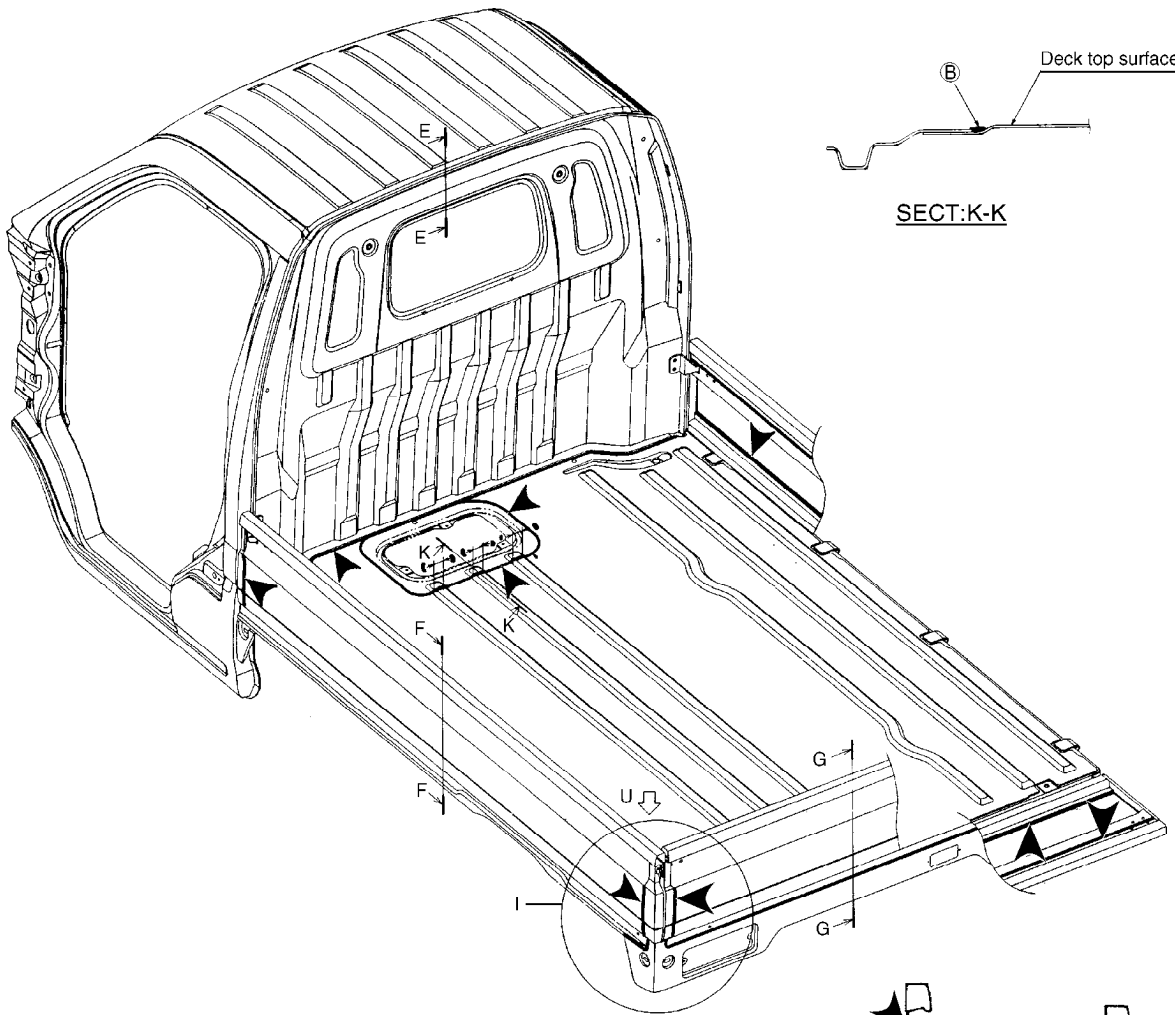
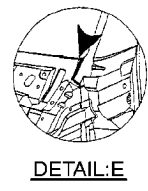
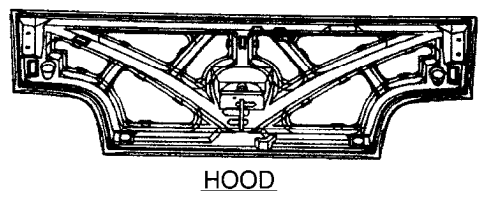
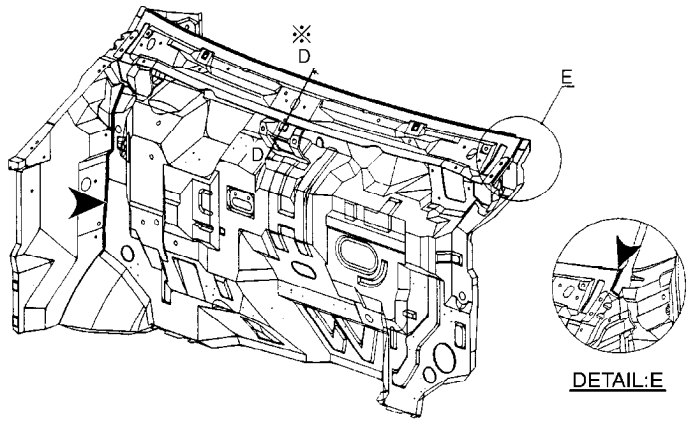

RUST-PROOF TREATMENT AREA

//// : Apply rust preventive to shaded area.

1 : Hot wax

2 : Underbody coat wax

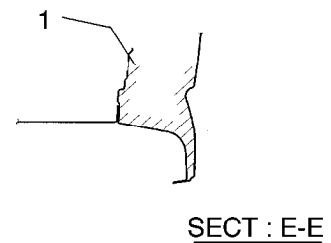
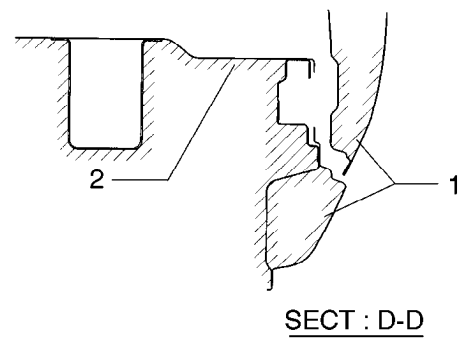
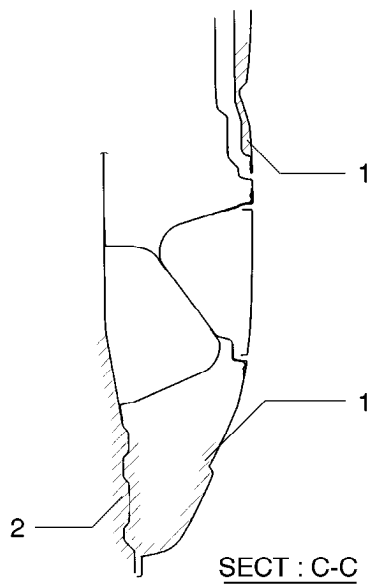
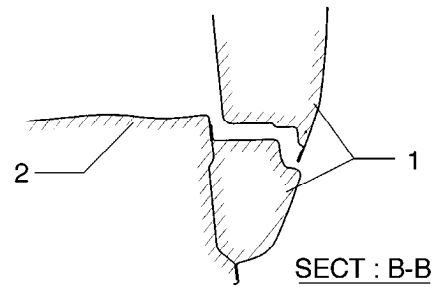
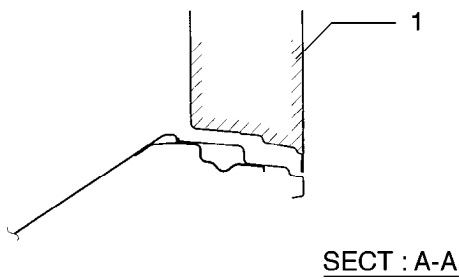
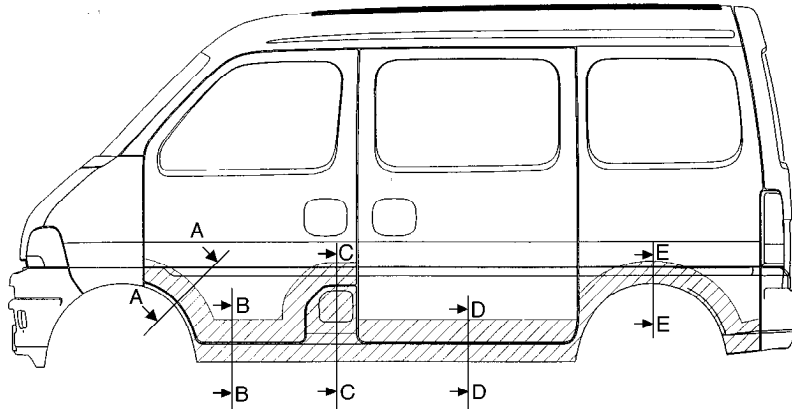

//// : Apply rust preventive to shaded area.

1 : Hot wax

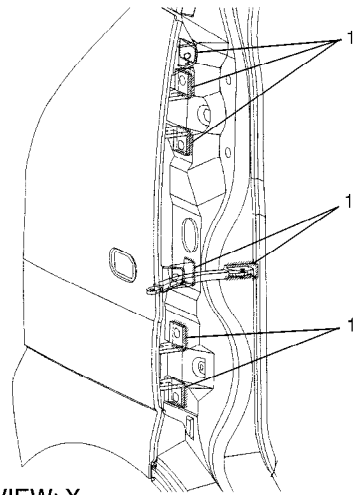
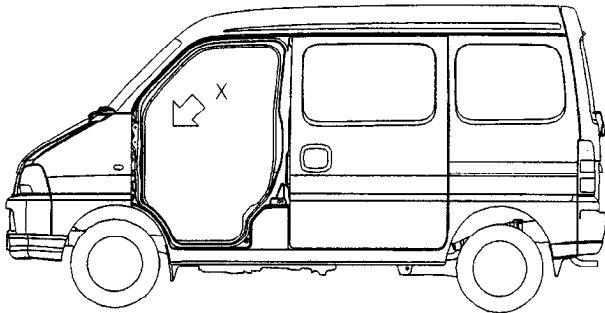

VIEW: X

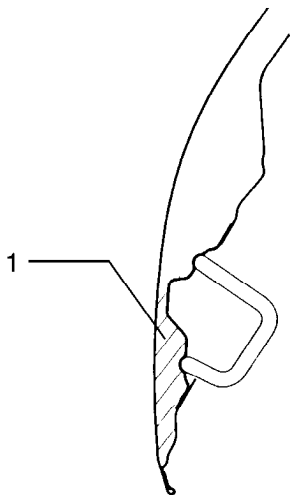
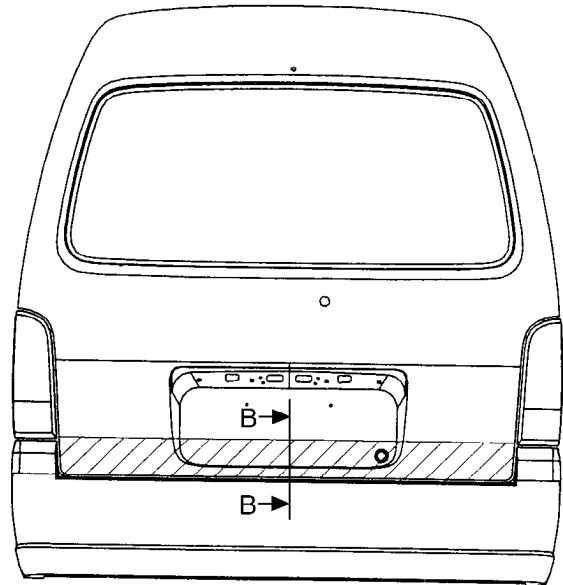
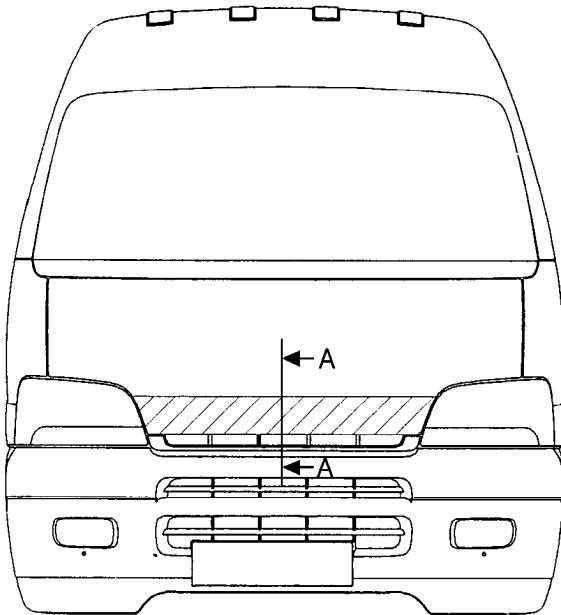

SECT : A-A

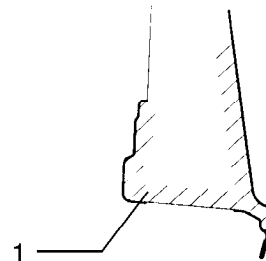

SECT : B-B

BODY DIMENSIONS

SIDE PANEL

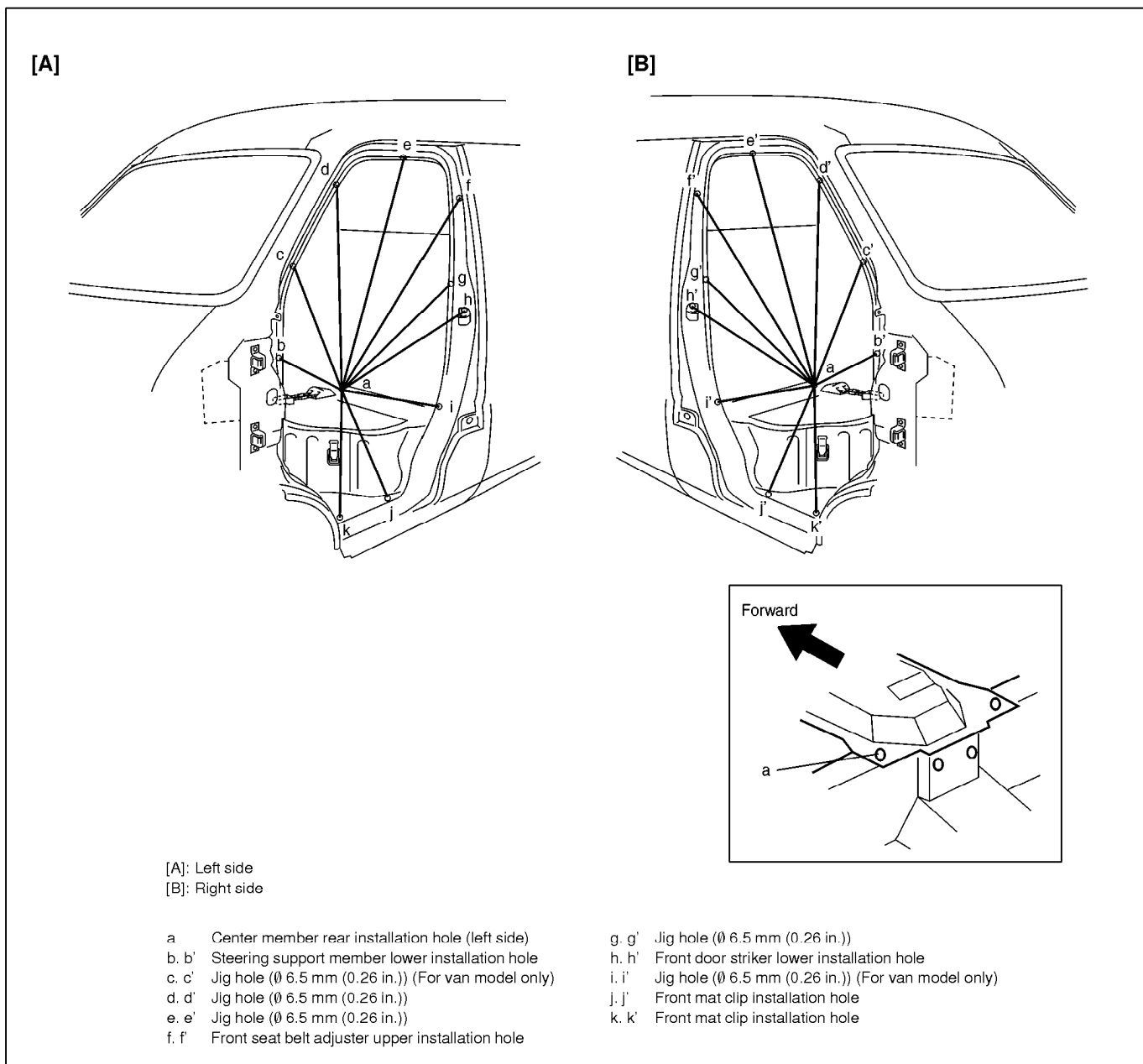

Measurement Dimension

a-b:	1032 mm	(40.63 in.)	a-b':	1160 mm	(45.67 in.)	c-c':	1274 mm	(50.16 in.)
a-c:	1086 mm	(42.76 in.)	a-c':	1208 mm	(47.56 in.)	d-d':	1193 mm	(46.97 in.)
a-d:	1104 mm	(43.46 in.)	a-d':	1217 mm	(47.91 in.)	e-e':	1132 mm	(44.57 in.)
a-e:	1085 mm	(42.72 in.)	a-e':	1194 mm	(47.01 in.)	f-f':	1133 mm	(44.61 in.)
a-f:	1027 mm	(40.43 in.)	a-f':	1142 mm	(44.96 in.)	g-g':	1261 mm	(49.65 in.)
a-g:	763 mm	(30.04 in.)	a-g':	927 mm	(36.50 in.)	h-h':	1349 mm	(53.11 in.)
a-h:	710 mm	(27.95 in.)	a-h':	895 mm	(35.24 in.)	i-i':	1244 mm	(48.98 in.)
a-i:	515 mm	(20.28 in.)	a-i':	734 mm	(28.90 in.)	j-j':	1220 mm	(48.03 in.)
a-j:	633 mm	(24.92 in.)	a-j':	818 mm	(32.20 in.)	k-k':	1220 mm	(48.03 in.)
a-k:	760 mm	(29.92 in.)	a-k':	920 mm	(36.22 in.)			

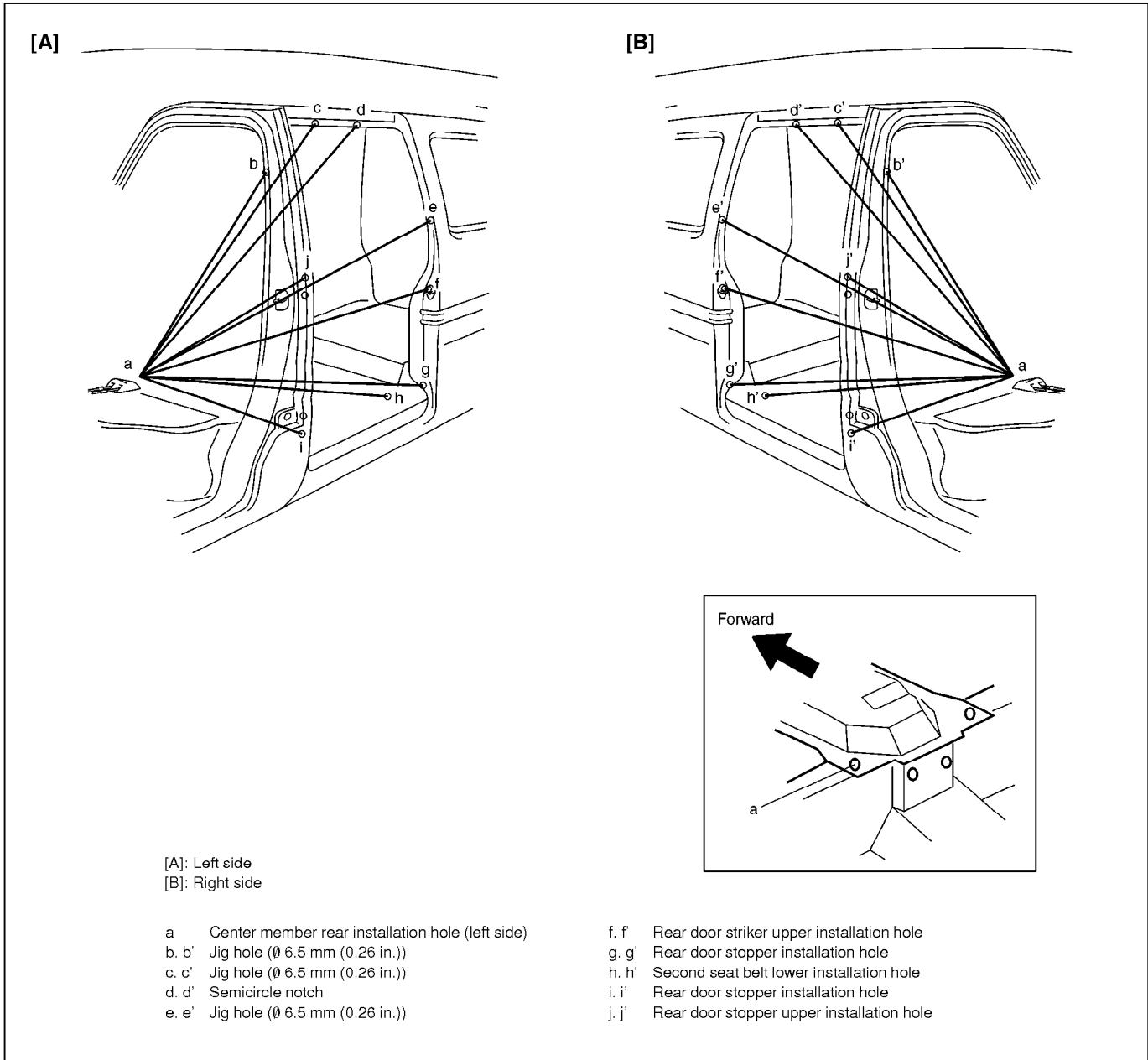

Measurement Dimension

a-b:	965 mm	(37.99 in.)	a-b':	1094 mm	(43.07 in.)	b-b':	1210 mm	(47.64 in.)
a-c:	1127 mm	(44.37 in.)	a-c':	1232 mm	(48.50 in.)	c-c':	1124 mm	(44.25 in.)
a-d:	1338 mm	(52.68 in.)	a-d':	1428 mm	(56.22 in.)	d-d':	1128 mm	(44.41 in.)
a-e:	1314 mm	(51.73 in.)	a-e':	1336 mm	(52.60 in.)	e-e':	1279 mm	(50.35 in.)
a-f:	1253 mm	(49.33 in.)	a-f':	1417 mm	(55.79 in.)	f-f':	1344 mm	(52.91 in.)
a-g:	1180 mm	(46.46 in.)	a-g':	1298 mm	(51.10 in.)	g-g':	1332 mm	(52.44 in.)
a-h:	1085 mm	(42.72 in.)	a-h':	1201 mm	(47.28 in.)	h-h':	1210 mm	(47.64 in.)
a-i:	622 mm	(24.49 in.)	a-i':	834 mm	(32.83 in.)	i-i':	1404 mm	(55.28 in.)
a-j:	823 mm	(32.40 in.)	a-j':	986 mm	(38.82 in.)	j-j':	1337 mm	(52.64 in.)

UNDERBODY DIMENSIONS

For van model

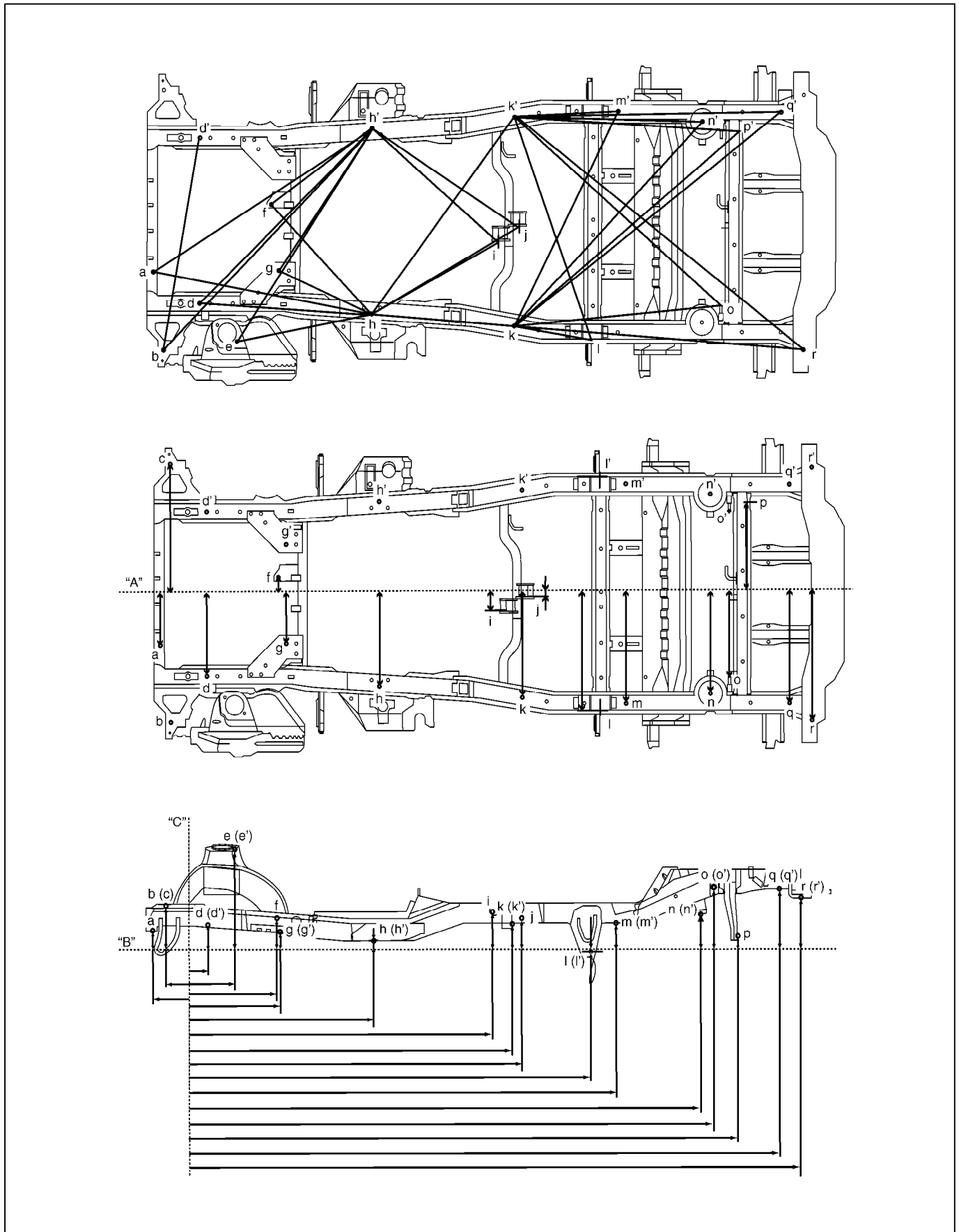

Hole Description

a:	Jig hole (∅ 10 mm (0.39 in.))	j:	Engine mounting right side installation hole (for 2WD model)
b:	Jig hole (∅ 12 mm (0.47 in.))		
c:	Jig hole (∅ 7 mm (0.28 in.))	k (k'):	Jig hole (∅ 15 mm (0.59 in.))
d (d'):	Front suspension frame front installation hole	l (l'):	Rear suspension arm outside installation hole
e (e'):	Front strut outside installation hole	m (m'):	Jig hole (∅ 15 mm (0.59 in.))
f:	Front differential installation hole (4WD model only)	n (n'):	Rear bumper stopper installation hole
		o (o'):	Rear shock absorber installation bolt end
g (g'):	Compression rod bracket installation hole	p:	Lateral rod backward installation hole
h (h'):	Engine mounting installation hole	q (q'):	Jig hole (∅ 15 mm (0.59 in.))
i (i'):	Engine mounting right side installation hole (for 4WD model)	r (r'):	Traction hook installation hole

Measurement Dimension

a-h:	1232 mm (48.50 in.)	g-h':	781 mm (30.75 in.)	k-p':	1451 mm (57.13 in.)
a-h':	1391 mm (54.76 in.)	h-i:	667 mm (26.26 in.)	k-q':	1603 mm (63.11 in.)
b-d':	1041 mm (40.98 in.)	h-j:	793 mm (31.22 in.)	k-r:	1398 mm (55.04 in.)
b-h':	1543 mm (60.75 in.)	h-k:	692 mm (27.24 in.)	k'-l:	1061 mm (41.77 in.)
d-h:	826 mm (32.52 in.)	h-k':	1118 mm (44.02 in.)	k'-m':	496 mm (19.53 in.)
d-h':	1139 mm (44.84 in.)	h'-i:	809 mm (31.85 in.)	k'-n':	913 mm (35.94 in.)
e-h:	811 mm (31.93 in.)	h'-j:	846 mm (33.31 in.)	k'-o:	1315 mm (51.77 in.)
e-h':	1239 mm (48.78 in.)	k-l:	402 mm (15.83 in.)	k'-p':	1091 mm (42.95 in.)
f-h:	713 mm (28.07 in.)	k-m':	1072 mm (42.20 in.)	k'-q':	1291 mm (50.83 in.)
f-h':	617 mm (24.29 in.)	k-n':	1284 mm (50.55 in.)	k'-r:	1732 mm (68.19 in.)
g-h:	490 mm (19.29 in.)	k-o:	994 mm (39.13 in.)		

Projection Dimension from Standard Line "A"

a:	250 mm (9.84 in.)	i:	126 mm (4.96 in.)	o (o'):	400 mm (15.75 in.)
b (c):	620 mm (24.41 in.)	j:	52 mm (2.05 in.)	p:	493 mm (19.41 in.)
d (d'):	369 mm (14.53 in.)	k (k'):	464 mm (18.27 in.)	q (q'):	487 mm (19.17 in.)
f:	78 mm (3.07 in.)	l (l'):	520 mm (20.47 in.)	r (r'):	563 mm (22.17 in.)
g (g'):	222 mm (8.74 in.)	m (m'):	487 mm (19.17 in.)		
h (h'):	416 mm (16.38 in.)	n (n'):	440 mm (17.32 in.)		

Projection Dimension from Standard Line "B"

a:	106 mm (4.17 in.)	h (h'):	58 mm (2.28 in.)	n (n'):	185 mm (7.28 in.)
b (c):	230 mm (9.06 in.)	i:	195 mm (7.68 in.)	o (o'):	323 mm (12.72 in.)
d (d'):	128 mm (5.04 in.)	j:	163 mm (6.42 in.)	p:	100 mm (3.94 in.)
e (e'):	530 mm (20.87 in.)	k (k'):	142 mm (5.59 in.)	q (q'):	309 mm (12.17 in.)
f:	128 mm (5.04 in.)	l (l'):	-3 mm (-0.12 in.)	r (r'):	280 mm (11.02 in.)
g (g'):	100 mm (3.94 in.)	m (m'):	142 mm (5.59 in.)		

Projection Dimension from Standard Line "C"

a:	-200 mm (-7.87 in.)	h (h'):	1020 mm (40.16 in.)	n (n'):	2616 mm (102.99 in.)
b (c):	-111 mm (-4.37 in.)	i:	1605 mm (63.19 in.)	o (o'):	2680 mm (105.51 in.)
d (d'):	198 mm (7.80 in.)	j:	1716 mm (67.56 in.)	p:	2795 mm (110.04 in.)
e (e'):	371 mm (14.61 in.)	k (k'):	1705 mm (67.13 in.)	q (q'):	2985 mm (117.52 in.)
f:	510 mm (20.08 in.)	l (l'):	2076 mm (81.73 in.)	r (r'):	3093 mm (121.77 in.)
g (g'):	572 mm (22.52 in.)	m (m'):	2200 mm (86.61 in.)		

For truck model

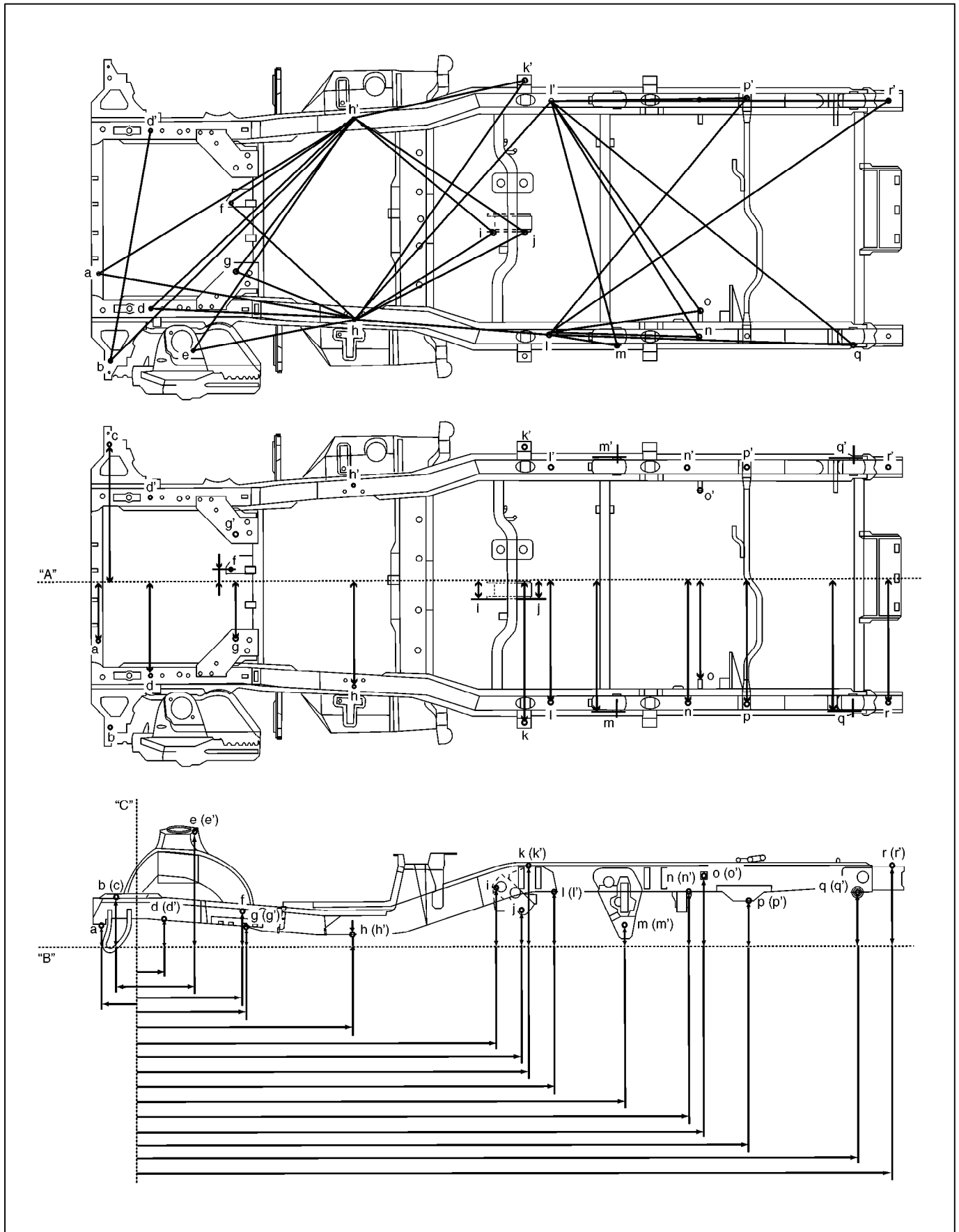

Hole Description

a:	Jig hole (∅ 10 mm (0.39 in.))	j:	Engine mounting right side installation hole (for 2WD model)
b:	Jig hole (∅ 12 mm (0.47 in.))		
c:	Jig hole (∅ 7 mm (0.28 in.))	k (k'):	Deck mounting hole
d (d'):	Front suspension frame front installation hole	l (l'):	Drain hole (∅ 20 mm (0.79 in.))
e (e'):	Front strut outside installation hole	m (m'):	Leaf spring outside installation hole
f:	Front differential installation hole (4WD model only)	n (n'):	Drain hole (∅ 15 mm (0.59 in.))
		o (o'):	Rear shock absorber installation bolt end
g (g'):	Compression rod bracket installation hole	p (p'):	Rear bumper stopper rear installation hole
h (h'):	Engine mounting installation hole	q (q'):	Leaf spring outside installation hole
i (i'):	Engine mounting right side installation hole (for 4WD model)	r (r'):	Deck mounting hole

Measurement Dimension

a-h:	1232 mm (48.50 in.)	g-h':	781 mm (30.75 in.)	l-o:	632 mm (24.89 in.)
a-h':	1391 mm (54.76 in.)	h-i:	734 mm (28.89 in.)	l-p':	1274 mm (50.16 in.)
b-d':	1041 mm (40.98 in.)	h-j:	806 mm (31.73 in.)	l-q:	1246 mm (49.06 in.)
b-h':	1543 mm (60.75 in.)	h-k':	1274 mm (50.16 in.)	l-r':	1697 mm (66.81 in.)
d-h:	826 mm (32.52 in.)	h-l:	813 mm (32.00 in.)	l'-m:	1067 mm (42.01 in.)
d-h':	1139 mm (44.84 in.)	h-l':	1243 mm (48.94 in.)	l'-n:	1127 mm (44.37 in.)
e-h:	811 mm (31.93 in.)	h'-i:	787 mm (30.98 in.)	l'-o:	1082 mm (42.60 in.)
e-h':	1239 mm (48.78 in.)	h'-j:	858 mm (33.78 in.)	l'-p':	809 mm (31.85 in.)
f-h:	713 mm (28.07 in.)	h'-k':	814 mm (32.05 in.)	l'-q:	1611 mm (63.43 in.)
f-h':	617 mm (24.29 in.)	l-m:	325 mm (12.80 in.)	l'-r':	1383 mm (54.45 in.)
g-h:	490 mm (19.29 in.)	l-n:	550 mm (21.65 in.)		

Projection Dimension from Standard Line "A"

a:	250 mm (9.84 in.)	i:	48 mm (1.89 in.)	o (o'):	392 mm (15.43 in.)
b (c):	620 mm (24.41 in.)	j:	52 mm (2.45 in.)	p (p'):	492 mm (19.37 in.)
d (d'):	369 mm (14.53 in.)	k (k'):	578 mm (22.76 in.)	q (q'):	531 mm (20.91 in.)
f:	78 mm (3.07 in.)	l (l'):	492 mm (19.37 in.)	r (r'):	492 mm (19.37 in.)
g (g'):	222 mm (8.74 in.)	m (m'):	525 mm (20.67 in.)		
h (h'):	416 mm (16.38 in.)	n (n'):	492 mm (19.37 in.)		

Projection Dimension from Standard Line "B"

a:	106 mm (4.17 in.)	h (h'):	58 mm (2.28 in.)	n (n'):	238 mm (9.37 in.)
b (c):	230 mm (9.06 in.)	i:	251 mm (9.88 in.)	o (o'):	310 mm (12.20 in.)
d (d'):	128 mm (5.04 in.)	j:	163 mm (6.42 in.)	p (p'):	200 mm (7.87 in.)
e (e'):	530 mm (20.87 in.)	k (k'):	352 mm (13.86 in.)	q (q'):	239 mm (9.41 in.)
f:	128 mm (5.04 in.)	l (l'):	238 mm (9.37 in.)	r (r'):	351 mm (13.82 in.)
g (g'):	100 mm (3.94 in.)	m (m'):	102 mm (4.02 in.)		

Projection Dimension from Standard Line "C"

a:	-200 mm (-7.87 in.)	h (h'):	1020 mm (40.16 in.)	n (n'):	2400 mm (94.49 in.)
b (c):	-111 mm (-4.37 in.)	i:	1625 mm (63.98 in.)	o (o'):	2470 mm (97.24 in.)
d (d'):	198 mm (7.80 in.)	j:	1731 mm (68.15 in.)	p:	2658 mm (104.65 in.)
e (e'):	371 mm (14.61 in.)	k (k'):	1760 mm (69.29 in.)	q (q'):	3095 mm (121.85 in.)
f:	510 mm (20.08 in.)	l (l'):	1850 mm (72.83 in.)	r (r'):	3228 mm (127.09 in.)
g (g'):	572 mm (22.52 in.)	m (m'):	2142 mm (84.33 in.)		

SECTION 10B

AIR BAG SYSTEM

WARNING:

- Service on or around the air bag system components or wiring must be performed only by an authorized SUZUKI dealer. Please observe all WARNINGS and SERVICE PRECAUTIONS of ON-VEHICLE SERVICE in this section before performing service on or around the air bag system components or wiring. Failure to follow WARNINGS could result in unintended activation of the system or could render the system inoperative. Either of these two conditions may result in severe injury.
- The procedures in this section must be followed in the order listed to disable the air bag system temporarily and prevent false diagnostic trouble codes from setting. Failure to follow procedures could result in possible activation of the air bag system, personal injury or otherwise unneeded air bag system repairs.

CAUTION:

When fasteners are removed, always reinstall them at the same location from which they were removed. If a fastener needs to be replaced, use the correct part number fastener for that application. If the correct part number fastener is not available, a fastener of equal size and strength (or stronger) may be used. Fasteners that are not reused, and those requiring thread-locking compound, will be called out. The correct torque value must be used when installing fasteners that require it. If the above conditions are not followed, parts or system damage could result.

NOTE:

For the descriptions (items) not found in this section, refer to the same section of the Service Manual mentioned in the FOREWORD of this manual.

CONTENTS

GENERAL DESCRIPTION	10B- 2	Accident with or without deployment/ activation - component inspections	10B- 3
System components and wiring location view and connectors	10B- 2	ON-VEHICLE SERVICE	10B- 6
DIAGNOSIS	10B- 3	Service Precautions	10B- 6
Repairs And Inspections Required After		Service and diagnosis	10B- 6
An Accident	10B- 3	Handling and storage	10B- 7
Accident with deployment/activation - component replacement	10B- 3	SDM	10B- 8

GENERAL DESCRIPTION

SYSTEM COMPONENTS AND WIRING LOCATION VIEW AND CONNECTORS

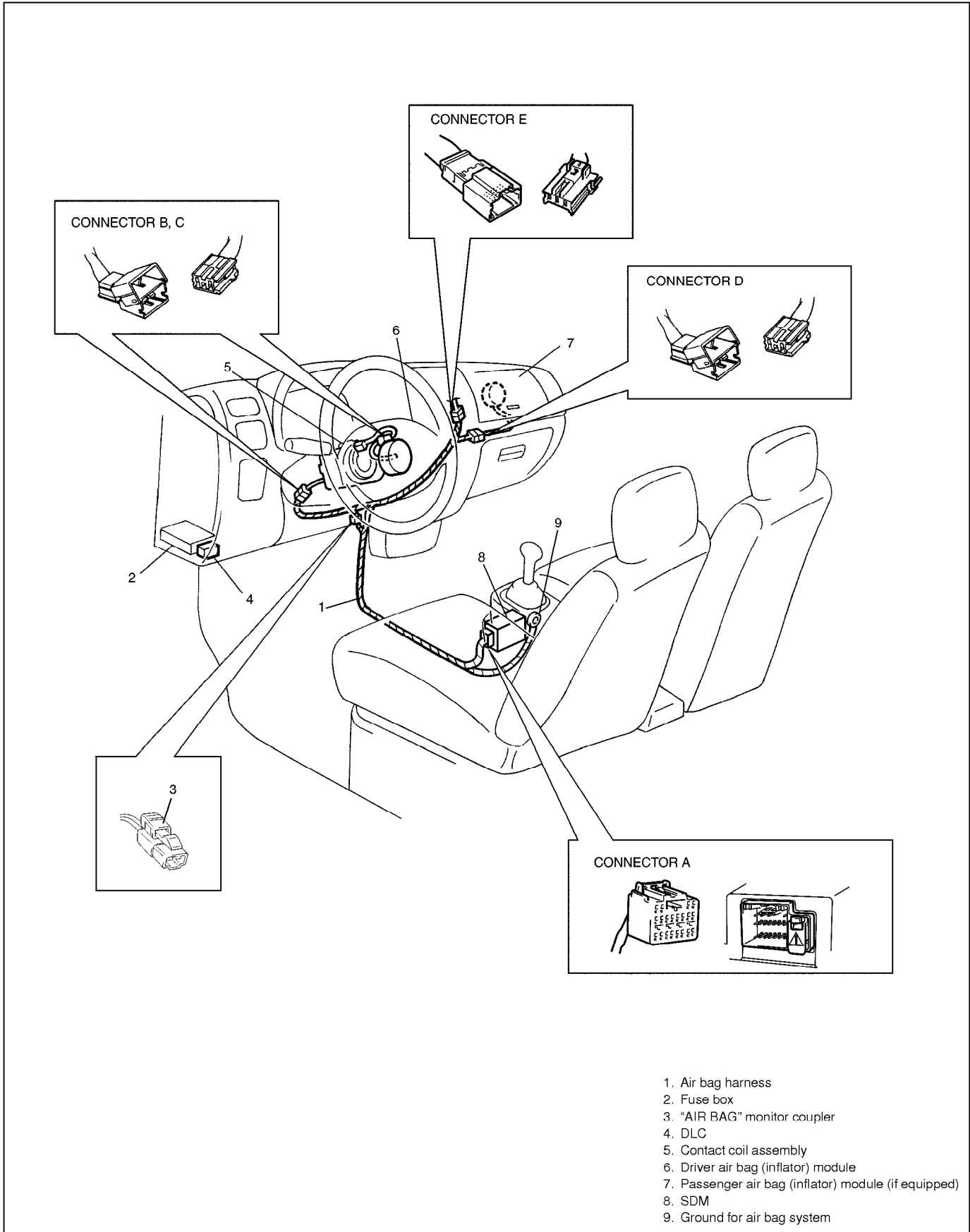

DIAGNOSIS

REPAIRS AND INSPECTIONS REQUIRED AFTER AN ACCIDENT

CAUTION:

- All air bag system components, including the electrical harness (component mounting points), must be inspected after an accident. If any components are damaged or bent, they must be replaced even if air bag system activation did not occur.
- Never use air bag system parts from another vehicle.
- Do not attempt to service the parts below. Service of these parts is by replacement only.
 - Driver air bag (inflator) module/Passenger air bag (inflator) module (if equipped)
 - SDM
 - Contact coil and combination switch assembly
 - Air bag wire harness
- Proper operation of the sensors and air bag system requires that any repairs to the vehicle structure return it to its original production configuration.

CAUTION:

After detecting one time of such collision as to meet deployment conditions, the SDM must not be used. Refer to AIR BAG DIAGNOSTIC SYSTEM CHECK in this section when checking the SDM.

ACCIDENT WITH DEPLOYMENT/ACTIVATION – COMPONENT REPLACEMENT

Certain air bag system components must be replaced. Those components are:

- Driver air bag (inflator) module and passenger air bag (inflator) module (if equipped)
 - Replace with new one.
- SDM after detecting such collision as to meet deployment conditions
 - Replace with new one.

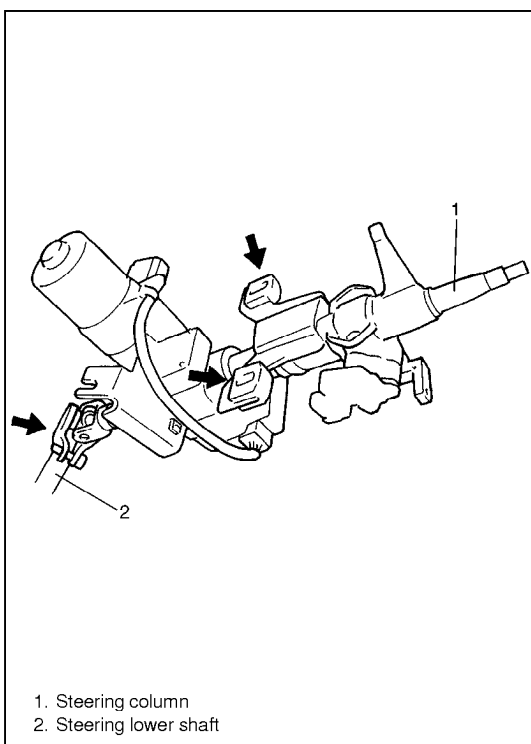

ACCIDENT WITH OR WITHOUT DEPLOYMENT/ACTIVATION – COMPONENT INSPECTIONS

Certain air bag and restraint system components must be inspected after any crash, whether the air bag deployed or not.

Those components are:

- Steering column and shaft joints
 - Check for length, damage and bend according to CHECKING STEERING COLUMN FOR ACCIDENT DAMAGE in SECTION 3C.

If any faulty condition is found in above checks, replace faulty part.

- Steering column bracket and capsules
 - Check for damage and bent.

If any faulty condition is found in above checks, replace faulty part.

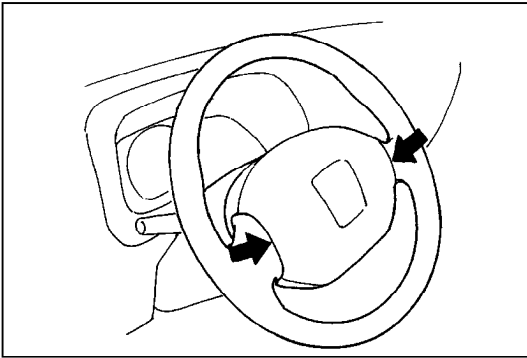

- Steering wheel and driver air bag (inflator) module
 - Check for damage or air bag (inflator) module fitness.
 - Check trim cover (pad surface) for cracks.
 - Check wire harness and connector for damage or tightness.
 If any faulty condition is found in above checks, replace faulty part.

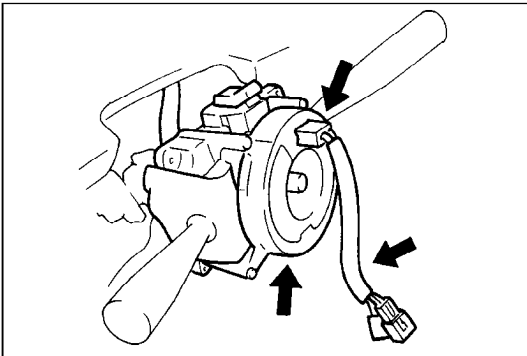

- Contact coil and combination switch assembly
 - Check wire harness and connectors for damage or tightness.
 - Check contact coil case for damage.
 If any faulty condition is found in above checks, replace.

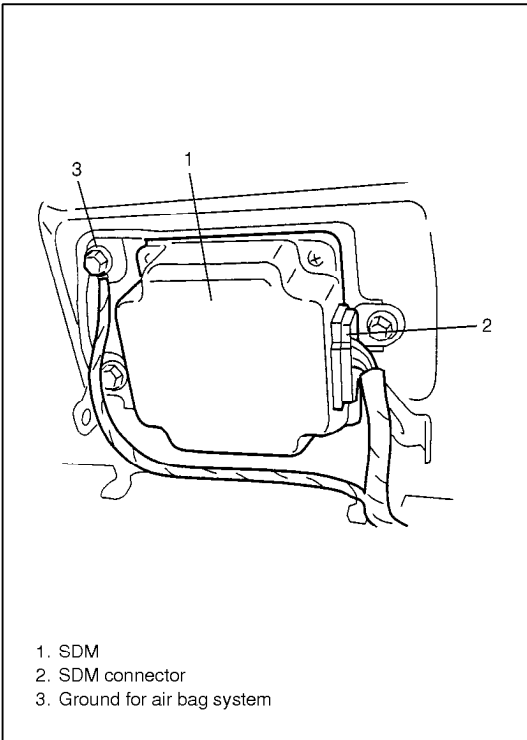

- SDM and SDM plate
 - Check for external damage such as deformation, scratch, crack, peeled paint, etc.
 - Check that SDM cannot be installed properly due to a cause in itself. (There is a gap between SDM and SDM plate, or it cannot be fixed securely.)
 - Check that connector or lead wire of SDM has a scorching, melting or damage.
 - Check that connector is connected securely or locked.
 - Check SDM connector and terminals for tightness.
 - Check SDM sets a diagnostic trouble code (Refer to AIR BAG DIAGNOSTIC SYSTEM CHECK in this section.) and the diagnostic table leads to a malfunctioning SDM.
 If any faulty condition is found in above checks, replace.

- Instrument panel member and reinforcement
 - Check for any distortion, bending, cracking or other damage.
 If any faulty condition is found in above checks, replace.

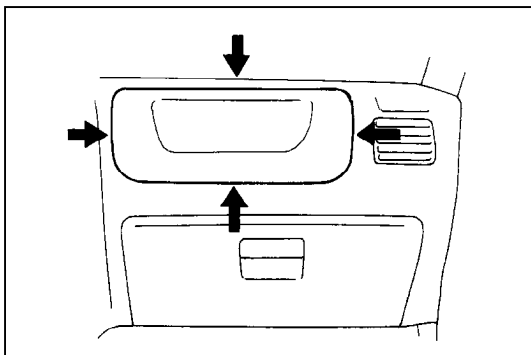

- Passenger air bag (inflator) module (if equipped)
 - Check for dents, cracks, damage or fitness.
 - Check trim cover for cracks or deformities.
 - Check harness and connector for damage or tightness.
 If any faulty condition is found in above checks, replace.

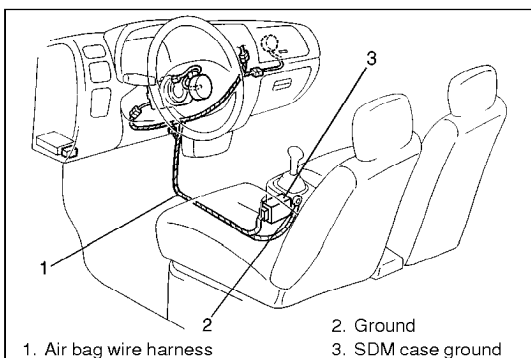

- Air bag wire harness and connections
 - Check for damages, deformities or poor connections.
(Refer to INTERMITTENTS AND POOR CONNECTIONS in this section.)
 - Check wire harness clamps for tightness.
 If any faulty condition is found, correct or replace.

- Seat belts and mounting points
 - Refer to FRONT SEAT BELT in SECTION 10A.
- “AIR BAG” warning lamp (air bag system)
 - After vehicle is completely repaired, perform AIR BAG DIAGNOSTIC SYSTEM CHECK in this section.

ON-VEHICLE SERVICE

SERVICE PRECAUTIONS

SERVICE AND DIAGNOSIS

WARNING/CAUTION labels are attached on each part of air bag system components (SDM, air bag (inflator) modules). Be sure to follow the instructions.

WARNING:

- If the air bag system and another vehicle system both need repair, Suzuki recommends that the air bag system be repaired first, to help avoid unintended air bag system activation.
- Do not modify the steering wheel, dashboard or any other air bag system components. Modifications can adversely affect air bag system performance and lead to injury.
- Failure to follow procedures could result in possible air bag system activation, personal injury or unneeded air bag system repairs.

- Many of service procedures require disconnection of "AIR BAG" fuse and air bag (inflator) module(s) (driver and passenger (if equipped)) from initiator circuit to avoid an accidental deployment.
- Do not apply power to the air bag system unless all components are connected or a diagnostic chart requests it, as this will set a diagnostic trouble code.
- The AIR BAG DIAGNOSTIC SYSTEM CHECK must be the starting point of any air bag diagnostics. The AIR BAG DIAGNOSTIC SYSTEM CHECK will verify proper "AIR BAG" warning lamp operation and will lead you to the correct chart to diagnose any air bag malfunctions. Bypassing these procedures may result in extended diagnostic time, incorrect diagnosis, and incorrect parts replacements.
- Never use air bag component parts from another vehicle.
- If the vehicle will be exposed to temperatures over 93°C (200°F) (for example, during a paint baking process), remove the air bag system components beforehand to avoid component damage or unintended system activation.
- When servicing, if shocks may be applied (e.g., dropped from a height of 90 cm (3 ft) or more) to air bag system component parts, remove those parts beforehand.
- When using electric welding, be sure to disconnect air bag (inflator) module connectors (driver and passenger) respectively.
- When applying paint around the air bag system related parts, use care so that the harness or connector will not be exposed to the paint mist.
- Never expose air bag system component parts directly to hot air (drying or baking the vehicle after painting) or flames.

WARNING:

When performing service on or around air bag system components or air bag wiring, follow the procedures listed in the following pages to temporarily disable the air bag system. Failure to follow procedures could result in possible air bag system activation, personal injury or unneeded air bag system repairs.

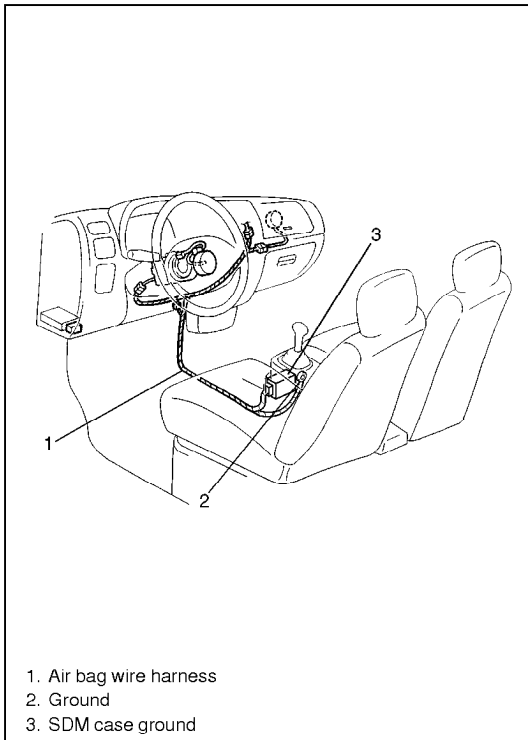

HOLDING AND STORAGE

AIR BAG WIRE HARNESS AND CONNECTORS

Air bag wire harness can be identified easily as it is covered with a yellow and black protection tube. Be very careful when handling it.

- When an open in air bag wire harness, damaged wire harness, connector or terminal is found, replace wire harness, connectors and terminals as an assembly.
- When installing it, be careful so that the air bag wire harness is not caught or does not interfere with other parts.
- Make sure all air bag system grounding points are clean and grounds are securely fastened for optimum metal-to-metal contact. Poor grounding can cause intermittent problems that are difficult to diagnose.

SDM

WARNING:

During service procedures, be very careful when handling a Sensing and Diagnostic Module (SDM). Be sure to read **SERVICE PRECAUTIONS** in this section before starting to work and observe every precaution during work. Neglecting them may result in personal injury or inactivation of the air bag system when necessary.

REMOVAL

- 1) Disconnect negative cable at battery.
- 2) Disable air bag system. Refer to **DISABLING AIR BAG SYSTEM** of **SERVICE PRECAUTIONS** in this section.
- 3) Remove console box by removing screws and clips.
- 4) Remove SDM cover.
- 5) Disconnect SDM connector from SDM.
- 6) Remove SDM (with SDM plate) as an assembly from vehicle.

NOTE:

Do not separate SDM and SDM plate.

INSPECTION

CAUTION:

- Do not connect a tester whatever type it may be.
- Never repair or disassemble SDM.
- If SDM was dropped from a height of 90 cm (3 ft) or more, it should be replaced.

- Check SDM and SDM plate for dents, cracks or deformation.
 - Check SDM connector for damage, cracks or lock mechanism.
 - Check SDM terminal for bent, corrosion or rust.
- If any faulty condition is found in above checks, replace.

INSTALLATION

For installation, reverse removal procedure, nothing following points.

- Tighten SDM bolts to specified torque.

Tightening Torque

(a): 6 N·m (0.6 kg·m, 4.5 lb·ft)

- Connect SDM connector to SDM securely.
- Enable air bag system. Refer to **ENABLING AIR BAG SYSTEM** of **SERVICE PRECAUTIONS** in this section.

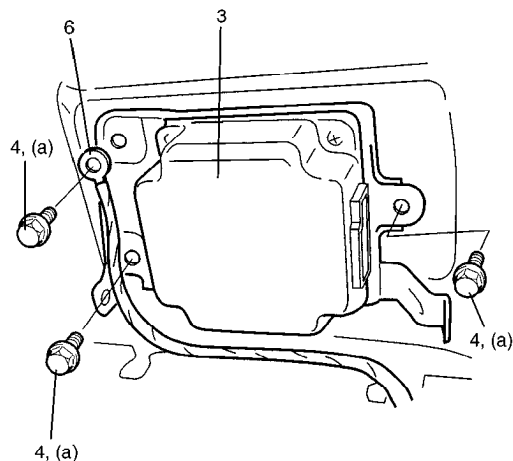
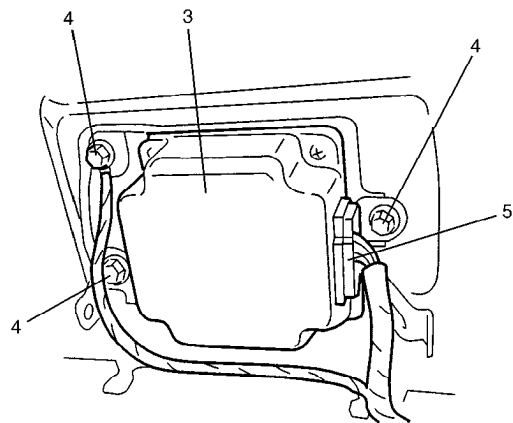
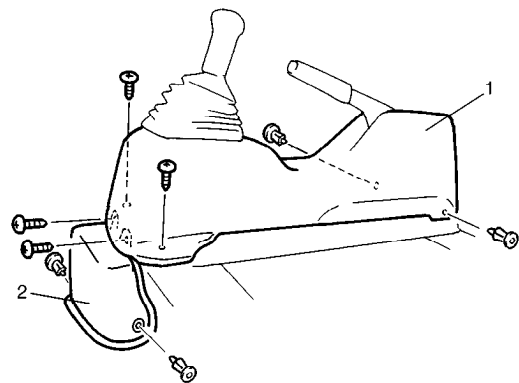

1. Console box
2. SDM cover
3. SDM
4. SDM bolt
5. SDM connector
6. Ground for air bag system

Prepared by

SUZUKI MOTOR CORPORATION

Overseas Service Department

1st Ed. October, 2000

Printed in Japan

Printing: October, 2000

262

EDIT Date: 18.05.2001